

The perfect solution for ventilation with acoustic control

PyrAcoust

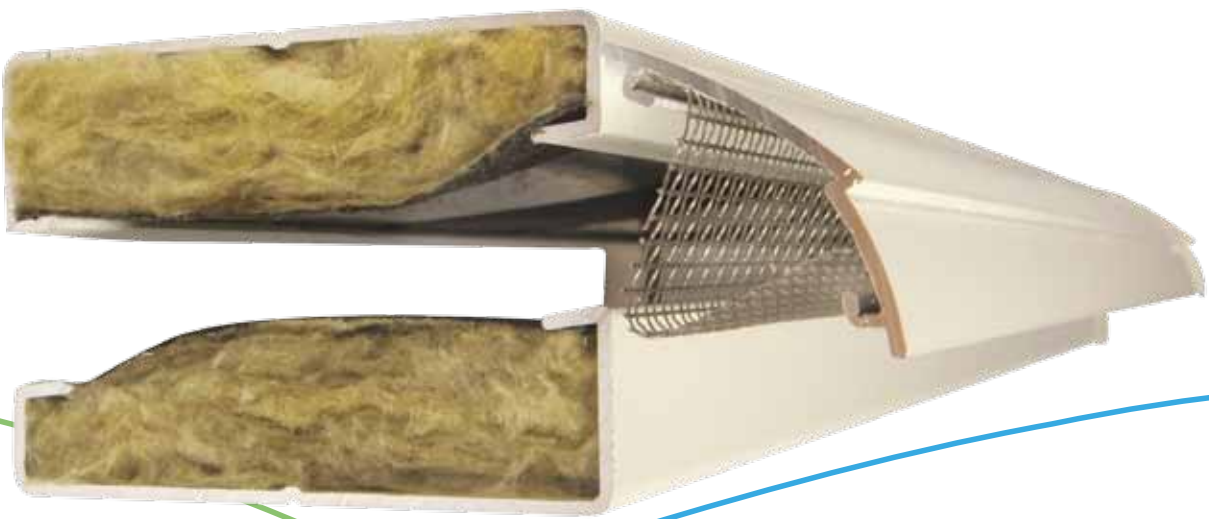

- Best acoustic performance available: up to 45 dB
- Achieves Part F requirement of 2500EA / 5000EA
- Modularity of acoustic sets
- Aesthetically pleasing design
- Excellent weather performance
- Easy to install

The perfect solution for ventilation with acoustic control

PyrAcoust

Product description



Based on our Pyramid vent, the PyrAcoust is the smallest acoustic window vent providing 2500 mm² or 5000 mm² Equivalent Area. The vent achieves the best acoustic performances for window ventilators available in the UK – up to 45 dB in the open position.

The modularity of acoustic sets provides flexibility for installation and acoustic performance. Sets comprise of:

- 1 Pyramid + 1 acoustic module (for internal or external installation) : providing noise reduction with discreet internal aesthetics
- 1 Pyramid + 2 acoustic modules (for internal and external installation): providing maximum noise reduction

The external canopy offers excellent weather protection and incorporates a stainless steel fly screen. The vent is easy to open and control by the homeowner. The upward air deflection reduces the risk of draughts. The PyrAcoust Vent is available in anodised silver or in any RAL colour, with black or white end caps. It is designed for use with Timber, PVCu and Aluminium windows.

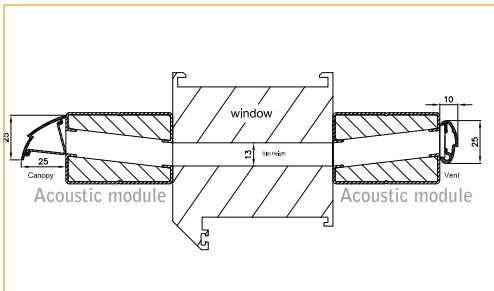

Product dimensions

Equivalent Area mm ²	Description	Sound absorption in open position		
		Dne,w	Dne,w (c)	Dne,w (ctr)
2500 EA	Vent + 1 Acoustic module	42 dB(A)	41 dB	40 dB
2500 EA	Vent + 2 Acoustic modules	45 dB(A)	43 dB	42 dB
5000 EA	Vent + 1 Acoustic module	39 dB(A)	38 dB	37 dB
5000 EA	Vent + 2 Acoustic modules	42 dB(A)	40 dB	38 dB

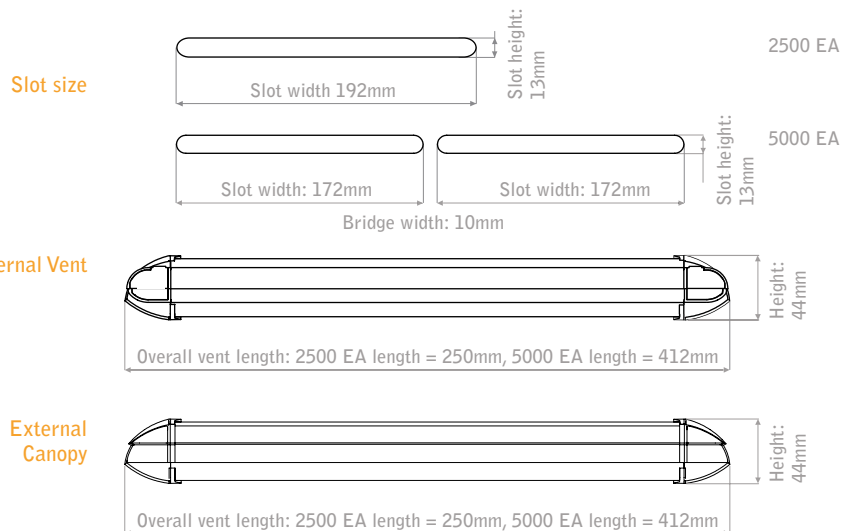

The last version of the technical brochure is available on www.aralco.be

All rights reserved. Nothing from this publication may be duplicated, saved in an automated database or made public, in any form or in any way, either electronically, mechanically, by photo copies, pictures or any other way, without preceding written permission from Aralco NVS.
© Aralco NVS, Waregem, 2014.

Aralco NVS

T +32 56 52 80 60
E info@aralco.be
I www.aralco.be

Better air, better life



aralco
natural ventilation systems