

- de MONTAGEANLEITUNG
- en MOUNTING INSTRUCTIONS
- fr INSTRUCTIONS DE MONTAGE
- it ISTRUZIONI DI MONTAGGIO
- es INSTRUCCIONES DE MONTAJE
- nl MONTAGEHANDLEIDING



**TRILUX**  
SIMPLIFY YOUR LIGHT

8841 / 8851

8841 ...  
8851 ...  
[www.trilux.com](http://www.trilux.com)

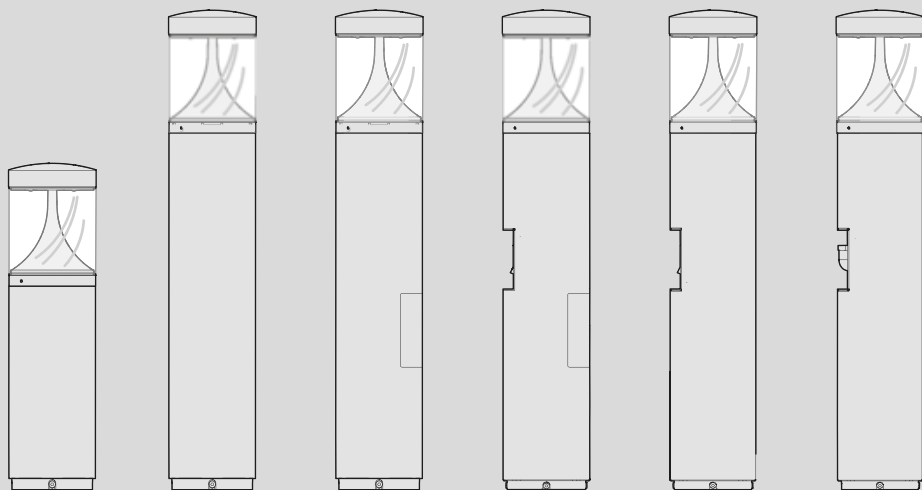

10203141 / VI 19

Lesen Sie zu Ihrer eigenen Sicherheit sorgfältig alle Hinweise und Montageschritte.  
Bewahren Sie die Anleitung für Wartungs- oder Demontearbeiten auf.



Der elektrische Anschluss darf nur von fachkundigem Personal durchgeführt werden, das hierfür ausgebildet und befugt ist.



**WARNUNG - Gefahr eines elektrischen Schlages!**

- Arbeiten Sie niemals bei anliegender Spannung an der Leuchte.



Die Lichtquelle dieser Leuchte muss vom Hersteller oder einem von ihm beauftragten Servicetechniker oder einer vergleichbar qualifizierten Person ersetzt werden.

**WARNUNG - Gefahr eines elektrischen Schlages!**

- Bei Störungen oder Ausfall der Lichtquelle wenden Sie sich bitte an TRILUX.



Die Lichtquelle dieser Leuchte ist ein Hochleistungs-LED-Modul.

**VORSICHT - Gefahr von Augenschädigungen!**

- Blicken Sie nicht in die aktive Lichtquelle. LED-Modul: **Risikogruppe 2**.
- Positionieren Sie die Leuchte so, dass ein längeres in die Leuchte starren in einem geringeren Abstand als 0,4 m nicht zu erwarten ist.

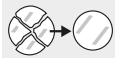

**Schutz vor herunterfallenden Glasbruchstücken.**

- Betreiben Sie die Leuchte nur mit einer unbeschädigten Abdeckscheibe.

**Wichtige Hinweise zu elektronischen Betriebsgeräten (EVG).**

- Eine Neutralleiterunterbrechung im Drehstromkreis führt zu Überspannungsschäden in der Beleuchtungsanlage. Öffnen Sie die Neutralleiter-Trennklemme nur spannungsfrei und schließen Sie die Neutralleiter-Trennklemme vor Wiedereinschalten.
- Die maximal zulässige Umgebungstemperatur  $t_a$  der Leuchte darf nicht überschritten werden. Eine Überschreitung reduziert die Lebensdauer, im Extremfall droht ein Frühausfall der Leuchte.
- Legen Sie die Anschlussleitungen für Steuereingänge dimmbarer EVG (1-10 V, DALI, etc.) 230 V netzspannungsfest (Basisisolierung) aus.

**Wichtige Hinweise zu Lasteinwirkungen.**

- Die Leuchte erfüllt die Anforderungen der IEC 60598 und ist ausgelegt für Einwirkungen durch Wind nach EN 1991 (Eurocode) mit einer Basisgeschwindigkeit von bis zu 30 m/s (entspricht Windzone 4 nach EN 40 in Deutschland) in der Geländekategorie 1. Berücksichtigt ist dabei eine Schneelast (bis zu 1 kN/m<sup>2</sup>) und eine Vereisung (bis zu 20 mm) bei einer Lichtpunkthöhe gemäß Montageanleitung. Nicht berücksichtigt sind Anpralllasten und exponierte Standorte, wie z. B. Brücken, Montage auf Gebäuden und Montage direkt neben Bahngleisen.

**Wichtige Hinweise zur Befestigung der Leuchte.**

- Bei LED-Außenleuchten der Schutzklasse II können witterungsbedingte statische Aufladungen des Leuchtengehäuses die Funktion und Lebensdauer der LED-Module beeinträchtigen. TRILUX empfiehlt: Führen Sie die Befestigung der Leuchte so aus, dass eine niederohmige elektrische Verbindung vom Leuchtengehäuse zum Erdreich besteht.

**Wichtige Hinweise zur Anschlussleitung.**

- Betreiben Sie die Leuchte nur mit einer unbeschädigten äußeren Leitung. Zur Vermeidung von Gefährdungen muss eine beschädigte äußere Leitung dieser Leuchte ausschließlich von TRILUX, seinem Servicepartner oder einer vergleichbar qualifizierten Person ersetzt werden.



**Bestimmungsgemäße Verwendung.**

- Bestimmt für den Außeneinsatz mit einer Umgebungstemperatur von:  $t_a$  25 °C
- Schutzklasse: **II**
- Schutzart: **IP65**



**Entsorgung von Elektro- und Elektronik-Altgeräten.**

- Sammeln und entsorgen Sie Elektro- und Elektronik-Altgeräte am Ende ihrer Lebensdauer immer getrennt. Holen Sie sich im Zweifel Auskunft zur umweltgerechten Entsorgung bei der örtlichen Kommunalbehörde oder speziellen Entsorgungsfachbetrieben ein.
- Wichtige Informationen zur Energieeffizienz von TRILUX-Leuchten sowie zur Leuchtenwartung und -entsorgung finden Sie im Internet: [www.trilux.com/eg245](http://www.trilux.com/eg245)

For your own safety, read all instructions and mounting steps carefully.  
Keep the instructions for maintenance or disassembly work.



The electrical connection shall only be carried out by professional personnel trained and authorised for this purpose.



**WARNING - risk of electric shock!**

- Never work on the luminaire with voltage applied.



The light source of this luminaire shall only be replaced by the manufacturer or a service technician authorised by the manufacturer or a comparably qualified person.

**WARNING - risk of electric shock!**

- If the light source malfunctions or fails, please contact TRILUX.



The light source of this luminaire is a high-performance LED module.

**CAUTION - risk of eye damage!**

- Do not stare into the active light source. LED module: **risk group 2**.
- Position the luminaire so that prolonged staring into the luminaire at a distance closer than 0.4 m is not expected.

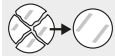

**Protection against falling glass fragments.**

- Operate the luminaire only with an undamaged cover.

#### Important information on electronic control gear units (ECG).

- A neutral conductor interruption in the three-phase circuit leads to overvoltage damage in the lighting system. Only open the neutral conductor isolating terminal in de-energized state, and close the neutral conductor isolating terminal before switching on again.
- Do not exceed the maximum permissible ambient temperature  $t_a$  of the luminaire. Exceeding this limit reduces the service life and in extreme cases there is a risk of premature failure of the luminaire.
- Lay out the connection cables for the control inputs of dimmable ECGs (1-10 V, DALI etc.) 230 V mains voltage-proof (basic insulation).

#### Important information on load effects.

- The luminaire meets the requirements of IEC 60598 and is designed for the exposure to wind according to EN 1991 (Eurocode) with basic velocity of up to 30 m/s (corresponds to wind zone 4 in Germany) in terrain category 1. A snow load (up to 1 kN/m<sup>2</sup>) and icing (up to 20 mm) at a mounting height according to the mounting instructions are taken into account. Impact loads and exposed locations such as bridges, installation on buildings and installation directly adjacent to railway tracks are not taken into account.

#### Important information on mounting the luminaire.

- With LED outdoor luminaires with safety class II, weather-induced static charges in the luminaire housing may impair the function and service life of the LED modules. TRILUX recommends: Mount the luminaire in such a way that there is a low-resistance electrical connection from the luminaire housing to the ground.

#### Important information on the connecting cable.

- Operate the luminaire only with an undamaged outer cable. To avoid hazards, a damaged outer cable of this luminaire shall only be replaced by TRILUX, its service partner or a comparably qualified person.



**Intended use.**

- Intended for outdoor use with an ambient temperature of:  $t_a$  25 °C
- Safety class: **II**
- Protection rating: **IP65**



**Disposal of waste electrical and electronic equipment.**

- Always collect and dispose of old electrical and electronic equipment separately at the end of its service life. In case of doubt, seek information about environmentally-compliant waste disposal from your local district authority or special waste disposal companies.
- For important information on the energy efficiency of TRILUX luminaires and on maintaining and disposing of luminaires, see the internet at: [www.trilux.com/ec245](http://www.trilux.com/ec245)

Pour votre propre sécurité, lisez attentivement toutes les remarques et étapes de montage. Conservez ces instructions pour des travaux d'entretien ou de démontage.



**Le raccordement électrique ne peut être effectué que par un personnel compétent, dûment formé et autorisé à effectuer de telles opérations.**



**AVERTISSEMENT: risque d'électrocution!**

- Ne travaillez jamais sur un luminaire sous tension.



**Seul le fabricant ou, soit un technicien de service mandaté par ce dernier, soit une personne ayant une qualification équivalente pourra se charger de remplacer la source de lumière de ce luminaire.**

**AVERTISSEMENT: risque d'électrocution!**

- En cas de perturbations ou défaillances de la source lumineuse, veuillez vous adresser à TRILUX.



**La source de lumière de ce luminaire est un module LED haute performance.**

**ATTENTION: risques de lésions oculaires!**

- Évitez de regarder dans la source de lumière active. Module LED: **groupe de risques 2**
- Positionnez le luminaire afin d'éviter d'y regarder longtemps à une distance inférieure à 0,4 m.

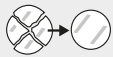

**Protection contre les éclats de verre tombant.**

- N'utilisez le luminaire qu'avec un diffuseur intact.

**Remarques importantes concernant les ballasts électroniques (EVG).**

- Une interruption du conducteur neutre dans le circuit de courant triphasé entraîne des dommages de surtension dans l'installation d'éclairage. Ouvrez la borne de coupure du conducteur neutre lorsque l'installation est hors tension et fermez-la avant la remise sous tension.
- Ne pas dépasser la température ambiante maximale admissible  $t_a$  du luminaire. Un dépassement réduit la durée de vie et peut, au pire, entraîner une défaillance prématurée du luminaire.
- Dimensionnez les câbles d'alimentation pour les entrées de commande de ballasts électroniques dimmables (1 à 10V, DALI, etc.) afin qu'ils supportent une tension de secteur de 230 V (isolation de base).

**Remarques importantes concernant les effets de charge.**

- Le luminaire satisfait aux exigences de la norme EN 60598, il a été conçu pour des actions du vent selon la norme EN 1991 (Eurocode), la valeur de base maximale de la vitesse de référence étant de 30m/s (correspondant à la zone de vent 4 en Allemagne selon EN 40) dans la catégorie de terrain I. Il sera tenu compte d'une charge de neige (maximale de 1kN/m<sup>2</sup>) et d'un givrage (maximal de 20cm) pour une hauteur utile conforme aux instructions de montage. Il ne sera pas tenu compte de sites exposés (ponts, montage sur des bâtiments ou directement près de voies ferrées).

**Remarques importantes concernant la fixation du luminaire.**

- Des charges statiques du boîtier des luminaires extérieurs LED de la classe électrique II, dues aux intempéries, pourraient affecter le fonctionnement et la durée de vie des modules LED. TRILUX vous recommande: de réaliser la fixation du luminaire en veillant à un raccordement électrique à basse impédance du boîtier de luminaire vers le sol.

**Remarques importantes concernant le câble d'alimentation.**

- N'utilisez le luminaire qu'avec un câble extérieur intact. Pour éviter tout risque, seul TRILUX, son partenaire de service ou une personne ayant une qualification équivalente pourra se charger de remplacer un câble extérieur endommagé de ce luminaire.



**Utilisation conforme à l'usage prévu.**

- Conçu pour une utilisation en extérieur à la température ambiante de  $t_a$  25 °C
- Classe électrique: II
- Indice de protection: **IP65**



**Élimination de DEEE.**

- À la fin de leur durée de vie, collectez et éliminez toujours les DEEE de manière sélective. Si vous avez des doutes sur une élimination sans danger pour l'environnement, demandez auprès des autorités locales ou d'entreprises de valorisation.

- Vous avez la possibilité de consulter des informations importantes concernant l'efficacité énergétique des luminaires TRILUX ainsi que l'entretien et l'élimination des luminaires sur le site Internet: **[www.trilux.com/ec245](http://www.trilux.com/ec245)**

Per la propria sicurezza, leggere con attenzione tutti gli avvisi e le descrizioni delle varie tappe della procedura di montaggio. Conservare le istruzioni per poterle consultare al momento di eseguire lavori di manutenzione e smontaggio.



**L'allacciamento elettrico deve essere realizzato da personale specializzato a ciò addestrato e autorizzato.**



**AVVERTENZA - Pericolo di scarica elettrica!**

- Mai lavorare sull'apparecchio in presenza di tensione.



**La sorgente luminosa di questo apparecchio deve essere sostituita dal produttore o da un tecnico di assistenza incaricato dallo stesso oppure da una persona in possesso di qualifica paragonabile.**

**AVVERTENZA - Pericolo di scarica elettrica!**

- In caso di disturbi o guasto della sorgente luminosa si prega di rivolgersi a TRILUX.



**La sorgente luminosa di questo apparecchio è un modulo LED High Power.**

**ATTENZIONE - Pericolo di lesioni agli occhi!**

- Non fissare lo sguardo sulla sorgente di luce attiva. Modulo LED: **gruppo di rischio 2.**
- Posizionare l'apparecchio in modo che, ad una distanza inferiore a 0,4 m, non ci si possa aspettare che vi si fissi lo sguardo a lungo.

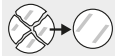

**Protezione contro la caduta di frammenti di vetro.**

- Impiegare l'apparecchio solo con un diffusore di copertura non danneggiato.

**Avvisi importanti sui reattori elettronici.**

- Un'interruzione del conduttore di neutro nel circuito trifase provoca danni da sovratensioni nell'impianto di illuminazione. Aprire il morsetto di sezionamento del conduttore di neutro solo senza tensione e chiuderlo prima del reinserimento.
- La massima temperatura ambiente ammissibile ( $t_a$ ) dell'apparecchio non deve essere oltrepassata. Questo ridurrebbe altrimenti la durata utile e, nel caso estremo, si rischierebbe un guasto precoce dell'apparecchio.
- Realizzare i cavi di allacciamento per ingressi di comando di reattori elettronici dimmerabili (1-10 V, DALI ecc.) in modo che presentino rigidità dielettrica con tensione di rete di 230 V (isolamento base)

**Avvisi importanti sul fissaggio dell'apparecchio.**

- In apparecchi per esterni a LED con classe d'isolamento II, a seconda delle condizioni atmosferiche, eventuali cariche statiche del corpo apparecchio potrebbero pregiudicare il funzionamento e la durata utile dei moduli LED. TRILUX consiglia pertanto di eseguire il fissaggio degli apparecchi in modo che sussista un collegamento elettrico a bassa impedenza del corpo apparecchio alla terra.

**Avvisi importanti sull'azione di carichi.**

- L'apparecchio soddisfa i requisiti della IEC 60598 ed è concepito per poter resistere all'azione del vento secondo EN 1991 (Eurocode) con una velocità di base di fino a 30m/s (corrispondente secondo EN 40 alla zona di vento 4 in Germania) nella categoria di terreno 1. Qui si tiene conto di un carico da neve (fino a 1kN/m<sup>2</sup>) e di un congelamento (fino a 20 mm) con un'altezza dei punti luminosi conforme alle istruzioni di montaggio. Carichi di impatto e siti esposti, come ad es. ponti, montaggio su edifici o direttamente accanto a binari ferroviari, non vengono tenuti in conto.

**Avvisi importanti per il cavo di collegamento.**

- Impiegare l'apparecchio solo con un cavo esterno privo di danni. Per evitare pericoli, un cavo esterno danneggiato di questo apparecchio deve essere sostituito esclusivamente da TRILUX, dal suo rappresentante di assistenza o da un tecnico specializzato con qualifica paragonabile.



**Impiego secondo destinazione.**

- Destinato all'impiego in esterni con una temperatura ambiente ( $t_a$ ) di 25 °C
- Classe di isolamento: II
- Grado di protezione: IP65



**Smaltimento di rifiuti di apparecchiature elettriche ed elettroniche.**

- Alla fine del loro periodo di durata utile, raccogliere e smaltire i rifiuti di apparecchiature elettriche ed elettroniche sempre in modo differenziato. Nel dubbio, si raccomanda di chiedere informazioni su uno smaltimento conforme alla normativa ambientale presso le autorità municipali del posto o aziende specializzate nello smaltimento di rifiuti.
- Per informazioni importanti sull'efficienza energetica degli apparecchi TRILUX e sulla manutenzione e smaltimento di apparecchi si rimanda: [www.trilux.com/ec245](http://www.trilux.com/ec245)

Para su propia seguridad, lea cuidadosamente todos los avisos y pasos de montaje. Guarde las instrucciones para los trabajos de mantenimiento y desmontaje.



La conexión eléctrica debe ser realizada exclusivamente por personal especializado que ha sido formado y autorizado para este fin.



**ADVERTENCIA - ¡Riesgo de descarga eléctrica!**

- Nunca realice trabajos en la luminaria si esta tiene tensión.



La fuente de luz de esta luminaria debe ser sustituida por el fabricante, por un técnico de servicio encargado por él o por una persona de cualificación similar.

**ADVERTENCIA - ¡Riesgo de descarga eléctrica!**

- En caso de fallos o averías de la fuente de luz, por favor, póngase en contacto con TRILUX.



La fuente de luz de esta luminaria es un módulo LED de alta potencia.

**ATENCIÓN - ¡Peligro de daños oculares!**

- No mire fijamente a la fuente de luz activa. Módulo LED: **grupo de riesgo 2**.
- Posicione la luminaria de tal manera que no se debe esperar que alguien mire fijamente durante un periodo elevado a la luz de la luminaria a una distancia menor de 0,4 m.

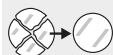

**Protección contra la caída de trozos de cristal.**

- Ponga en funcionamiento la luminaria solamente con un recubrimiento prismático intacto.

**Avisos importantes en lo referente a los balastos electrónicos (EVGs).**

- Una interrupción del conductor neutro en el circuito de corriente trifásica provoca daños por sobretensión en la instalación de iluminación. Solamente abra el borne desconector del conductor neutro cuando este esté desconectado de la tensión y cierre el borne desconector del conductor neutro antes de la reconexión.
- No debe sobrepasarse la temperatura ambiente máxima admitida  $t_a$  de la luminaria. Al sobrepasarla, la vida útil se reduce y, en un caso extremo, puede provocarse un fallo prematuro de la luminaria.
- Los cables de conexión para las entradas de control de los balastos electrónicos (EVGs) regulables (1-10 V, DALI, etc.) 230 V deben ser resistentes a la tensión de red (aislamiento básico).

**Avisos importantes en lo referente a las cargas.**

- La luminaria cumple con los requisitos de la IEC 60598 y ha sido diseñada para los efectos del viento según la EN 1991 (Eurocódigo) con una velocidad básica de hasta 30 m/s (corresponde a una zona de viento 4 según EN 40 en Alemania) para la categoría de terreno 1. Se tienen en cuenta una carga de nieve (de hasta 1 kN/m<sup>2</sup>) y una glaciación (de hasta 20 mm) con una altura del punto de luz según las instrucciones de montaje. No se han tenido en cuenta las cargas de impacto y los emplazamientos expuestos como, por ejemplo, puentes, montaje en edificios o montajes directamente al lado de vías ferroviarias.

**Avisos importantes en lo referente a la fijación de la luminaria.**

- En el caso de las luminarias LED exteriores de la clase de protección II, las cargas estáticas de la carcasa de la luminaria debidas a las condiciones climáticas pueden afectar el funcionamiento y la vida útil de los módulos LED. TRILUX recomienda: Realice la fijación de la luminaria de tal manera que exista una conexión eléctrica de baja resistencia entre la carcasa de la luminaria y la tierra.

**Avisos importantes en lo referente al cable de conexión.**

- Ponga en funcionamiento la luminaria solamente con un cable que no esté dañado por fuera. Para evitar peligros, un cable dañado por fuera de esta luminaria siempre debe ser sustituido por TRILUX, por su socio de servicio o por una persona de cualificación similar.



**Uso conforme.**

- Destinado para el uso en espacios exteriores con una temperatura ambiente:  $t_a$  25 °C
- Clase de protección: II
- Grado de protección: IP65



**Eliminación de dispositivos eléctricos y electrónicos antiguos.**

- Recoja y elimine los dispositivos eléctricos y electrónicos antiguos siempre por separado al final de su vida útil. En caso de duda, consulte las autoridades comunales o las empresas especializadas en eliminación de residuos para tener información sobre la eliminación respetuosa con el medio ambiente.
- En [www.trilux.com/ec245](http://www.trilux.com/ec245) encontrará información importante sobre la eficiencia energética de las luminarias de TRILUX y sobre su mantenimiento y eliminación.

Voor uw eigen veiligheid is het belangrijk dat u alle opmerkingen en montagestappen zorgvuldig leest.

Bewaar de handleiding voor latere onderhouds- of demontagewerkzaamheden.



De elektrische aansluiting moet worden uitgevoerd door vakkundig personeel, dat hiervoor opgeleid en bevoegd is.



**WAARSCHUWING - Gevaar voor een elektrische schok!**

- Werk nooit aan de armatuur terwijl deze onder spanning staat.



De lichtbron van deze armatuur moet worden vervangen door de fabrikant, een door de fabrikant gemachtigd servicetechnicus of een persoon met vergelijkbare kwalificaties.

**WAARSCHUWING - Gevaar voor een elektrische schok!**

- Neem contact op met TRILUX in geval van een storing of uitval van de lichtbron.



De lichtbron van deze armatuur is een hoogvermogen-LED-module.

**VOORZICHTIG! - Gevaar voor oogschade!**

- Staar niet in de lichtbron wanneer deze is ingeschakeld.  
LED-module: **risicogroep 2.riesgo 2.**
- Positioneer de armatuur zo dat niet te verwachten is dat iemand gedurende langere tijd vanaf een afstand van minder dan 0,4 m in de armatuur kijkt.

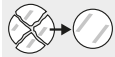

**Bescherming bij glasbreuk.**

- De armatuur mag niet gebruikt worden als het afdekglas schade vertoont.

**Belangrijke aanwijzingen voor elektronische voorschakelapparaten (EVSA).**

- Een onderbreking van de nulleider in de draaistroomkring veroorzaakt schade door overspanning in de verlichtingsinstallatie. Open de nulleider-nullem alleen als de kring spanningsvrij is en sluit de nulleider-nullem alvorens de spanning weer in te schakelen.
- De maximaal toelaatbare omgevingstemperatuur (ta) van de armatuur mag niet overschreden worden. Overschrijding van de maximumtemperatuur kan de levensduur van de armatuur verkorten en in extreme gevallen zelfs leiden tot vroegtijdige uitval.
- Leg aansluitleidingen voor de sturingangen van de dimbare EVSA (1...10 V, DALI enz.) 230 V die geschikt zijn voor de netspanning (basisisolatie).

**Belangrijke aanwijzingen met betrekking tot de inwerking van lasten.**

- De armatuur voldoet aan de eisen van IEC 60598 en is bestand tegen windinwerking conform EN 1991 (Eurocode) met een basissnelheid van maximaal 30 m/s (wat overeen stemt met windzone 4 conform EN 40 in Duitsland) en terreincategorie 1. Daarbij is rekening gehouden met een sneeuwlast (maximaal 1 kN/m<sup>2</sup>) en ijsafzetting (maximaal 20 mm) bij een lichtpunthoogte conform de montagehandleiding. Er is geen rekening gehouden met de belasting van een impact of een plaats met veel blootstelling, bijv. montage op een brug of gebouw, direct naast een spoorweg.

**Belangrijke aanwijzingen voor de bevestiging van de armatuur.**

- Bij LED-buitenarmaturen van beschermcategorie II kan de weersgebonden statische oplading van de armatuurbehuizing de werking en de levensduur van de LED-modules negatief beïnvloeden. Tip van TRILUX: Bevestig de armatuur zodanig dat er een laagohmse elektrische verbinding bestaat tussen de armatuurbehuizing en de aarde.

**Belangrijke aanwijzingen met betrekking tot de aansluitkabel.**

- Gebruik de armatuur alleen als de buitenkabel intact is. Om gevaar te voorkomen, mag een beschadigde buitenkabel uitsluitend worden vervangen door TRILUX, een servicepartner van TRILUX of een persoon met vergelijkbare kwalificaties.



**Bedoeld gebruik.**

- Bedoeld voor buitengebruik bij een omgevingstemperatuur van: **ta 25 °C**
- Beschermingsklasse: **II**
- Beschermklasse: **IP65**



**Afgedankte elektrische en elektronische apparaten verwijderen.**

- Afgedankte elektrische en elektronische apparaten moeten altijd gescheiden van het andere afval worden bewaard en afgevoerd. Vraag in geval van twijfel aan de plaatselijke bevoegde openbare dienst of een gespecialiseerd afvalverwerkingsbedrijf hoe u deze apparaten afdankt met respect voor het milieu.
- Belangrijke informatie over de energie-efficiëntie van TRILUX-armaturen evenals informatie over onderhoud en afvoer van armaturen vindt u terug op het internet: [www.trilux.com/ec245](http://www.trilux.com/ec245)

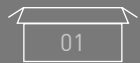

Type	≈ kg
8841 E-Block ...	2,3
8851 E-Block ...	2,3
L-Kopf 8841 AB ...	3,5
L-Kopf 8841 RB ...	3,5
L-Kopf 8851 AB ...	3,5
L-Kopf 8851 RB ...	3,5



Type	≈ kg
Standrohr 440	2,6
Standrohr 840	4,3
Standrohr 840 Ü	4,9
Standrohr 840 Ü S	5,1
Standrohr 840 S	5,1
Standrohr 840 PIR	5,1

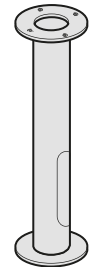
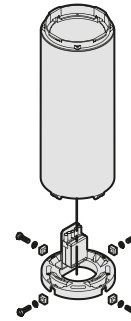
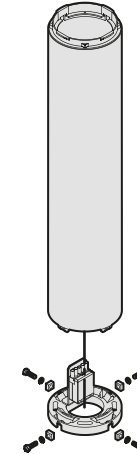
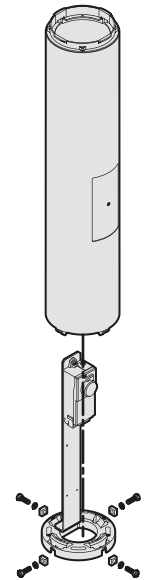
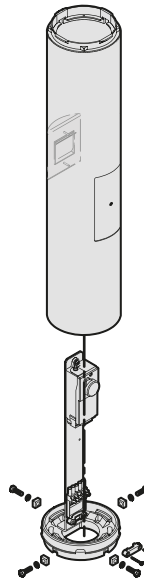
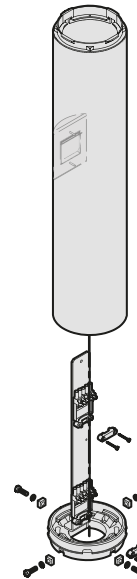
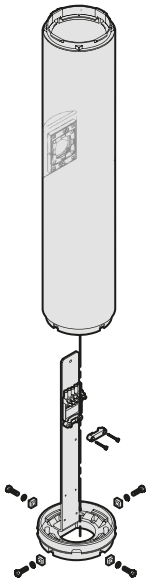

Type	TOC
08800 Erdstück	2221400

8841  
E-Block8851  
E-BlockL-Kopf  
8841 ...L-Kopf  
8851 ...08800  
ErdstückStandrohr  
440Standrohr  
840Standrohr  
840 ÜStandrohr  
840 Ü SStandrohr  
840 SStandrohr  
840 PIR



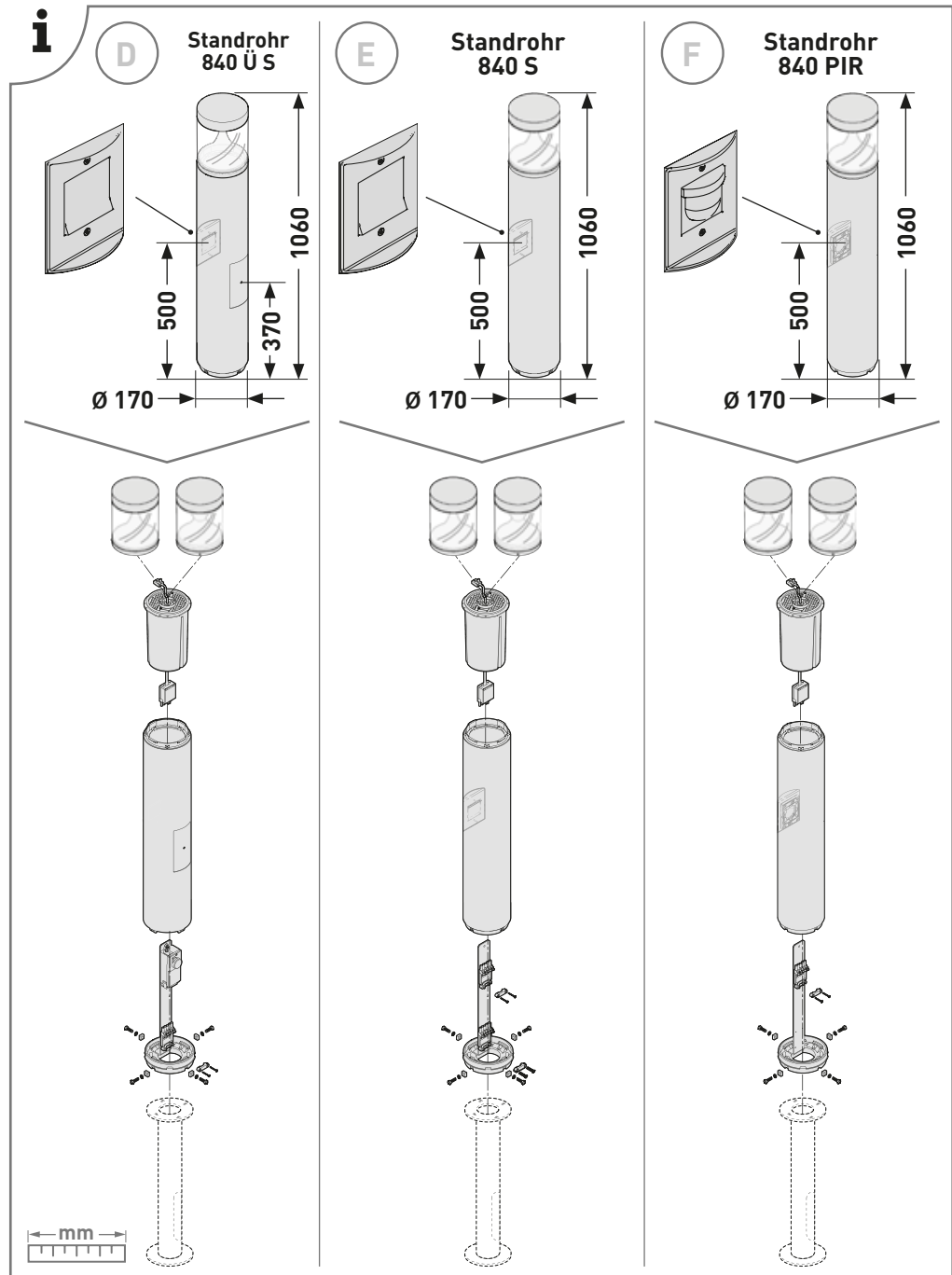
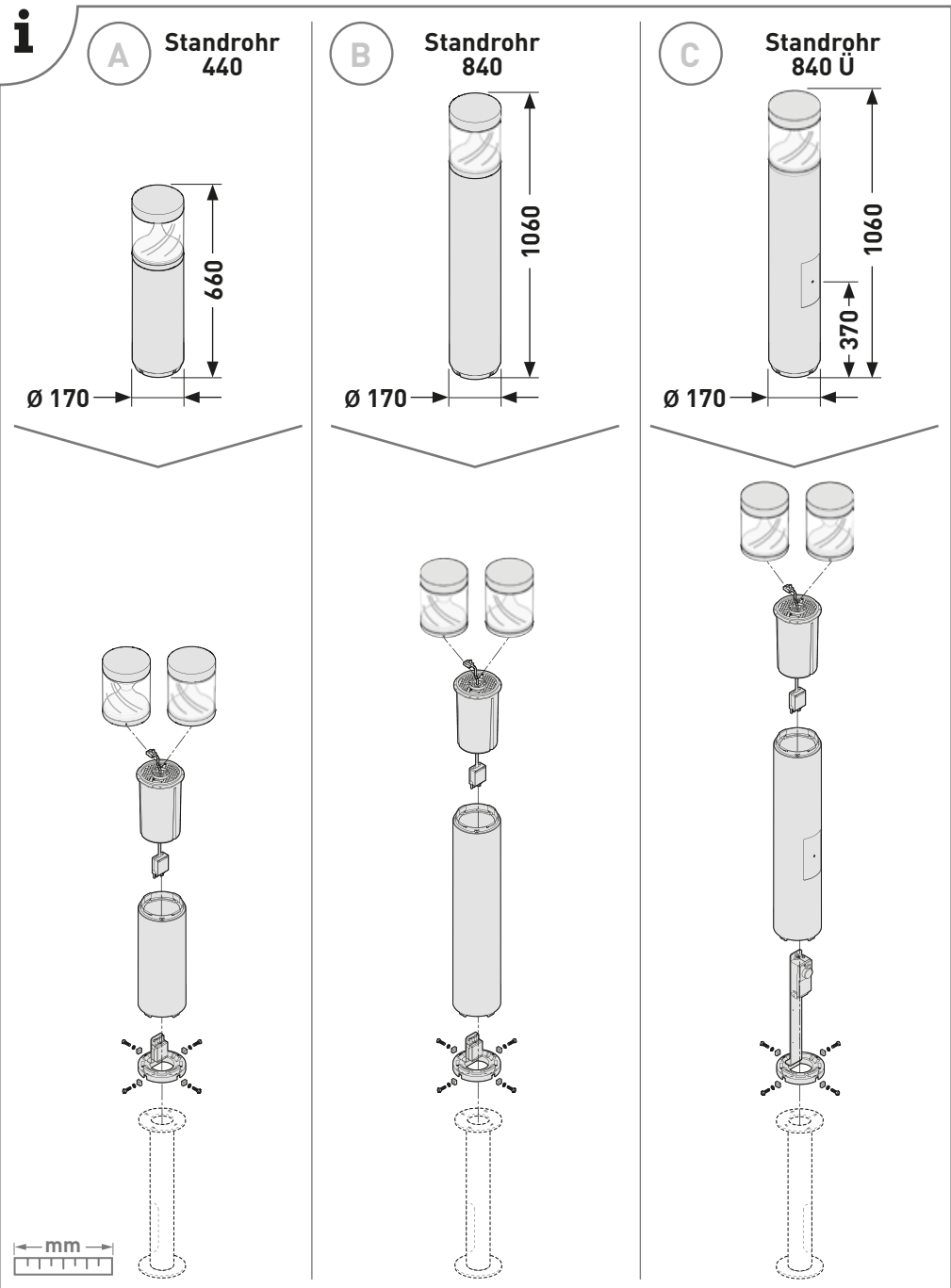

**i**

A B C D E F

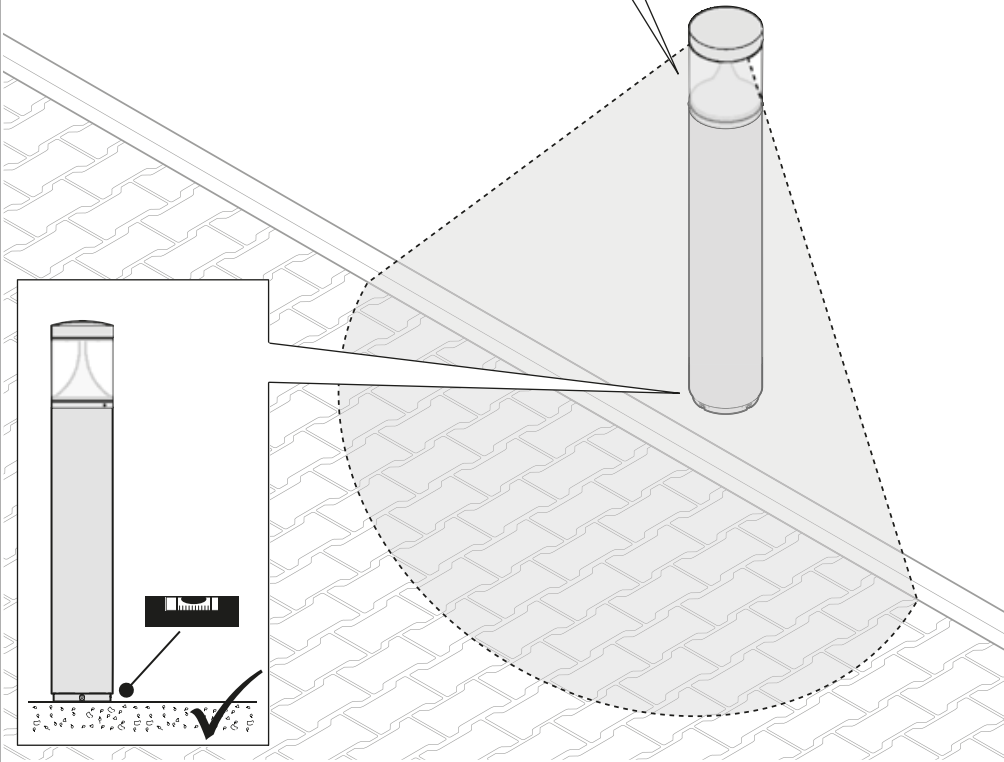
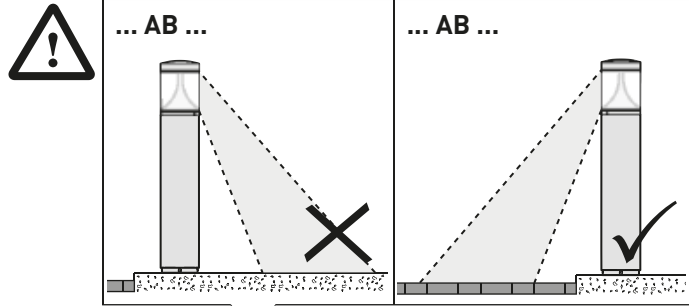

**i**

A B C F D E

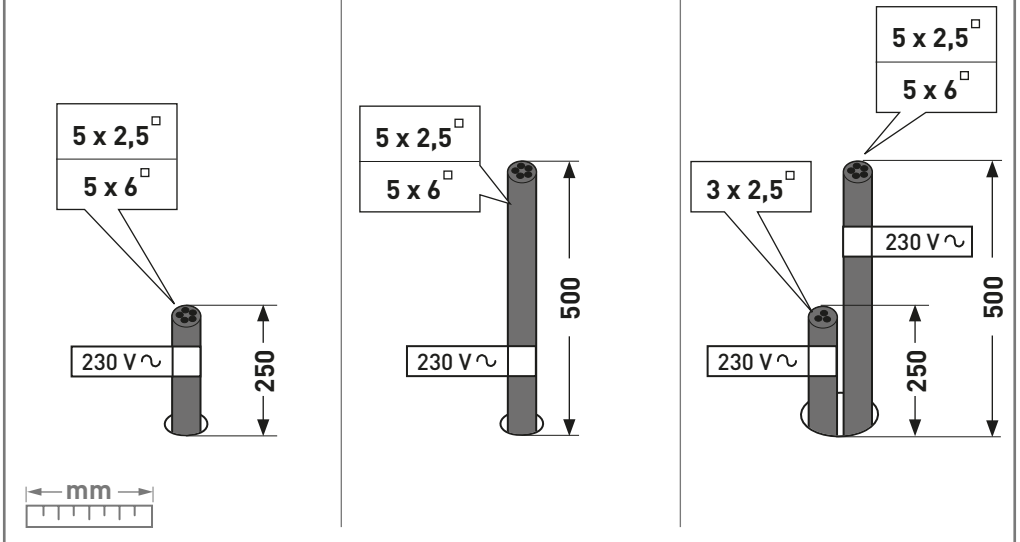

**1**

A B C D E F

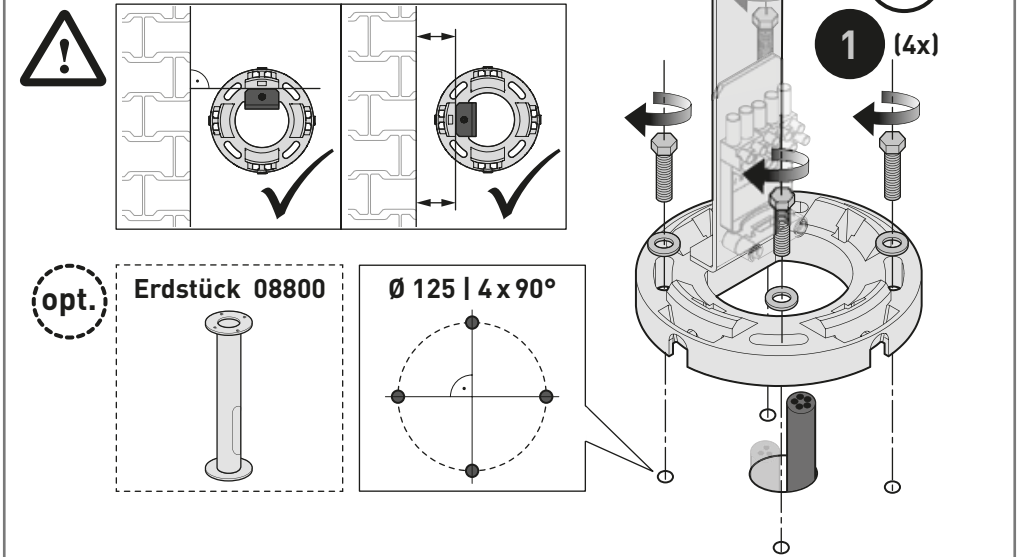

2 A B C D E F

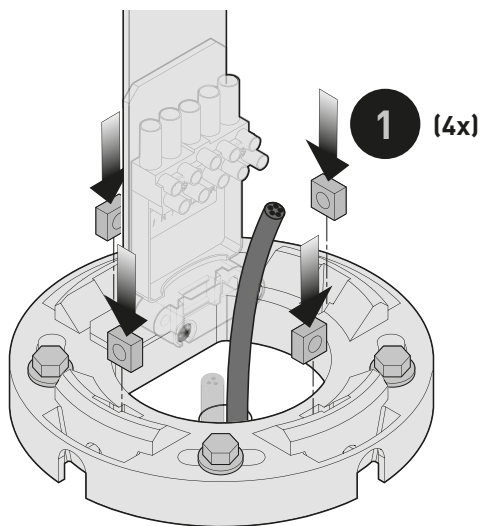

3 A B D E F

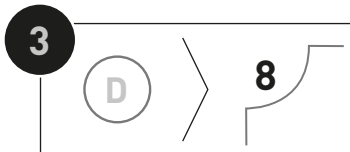
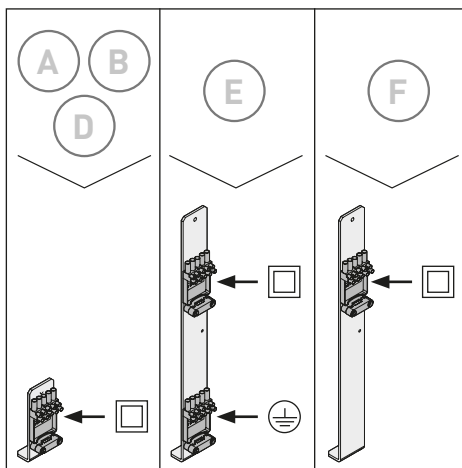
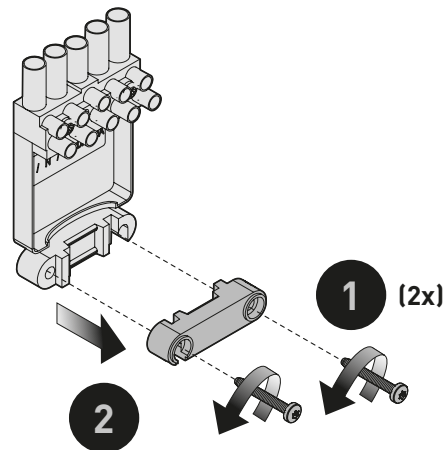

4 A B E F

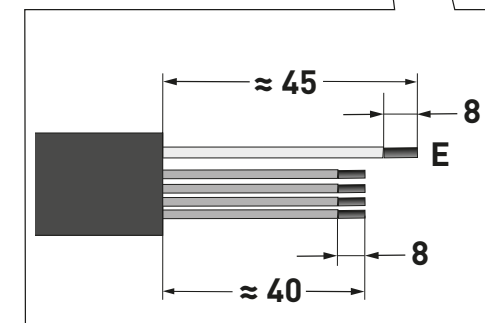
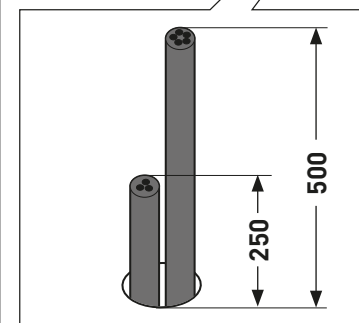
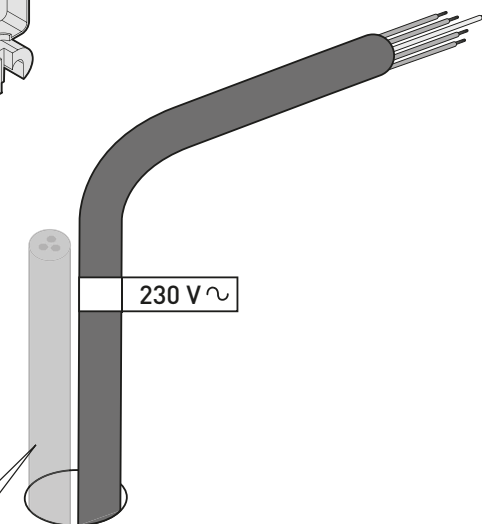
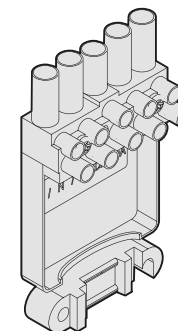
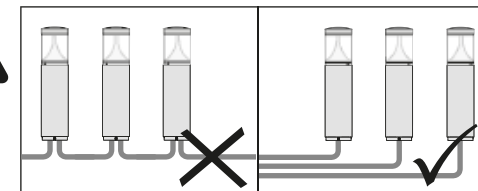

5

A B E F

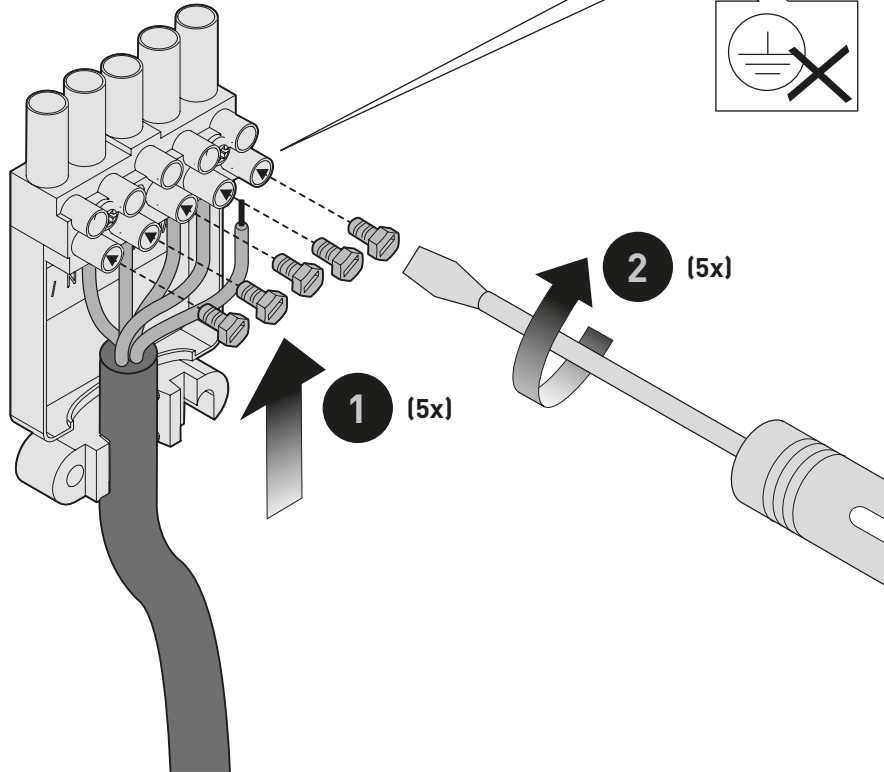
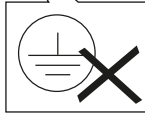
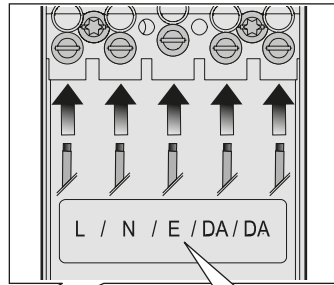
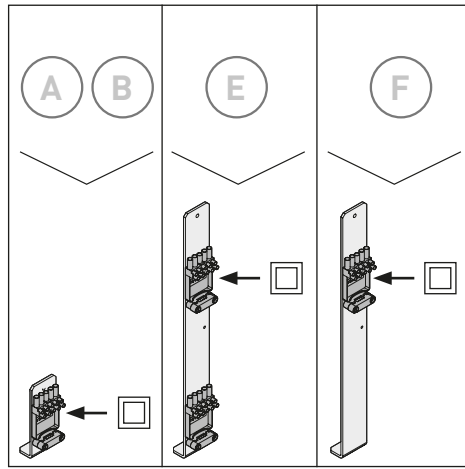

6

A B E F

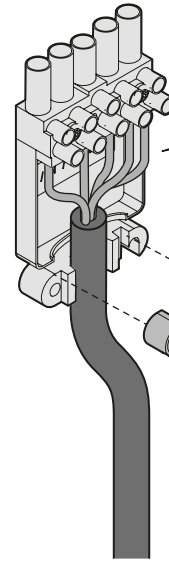
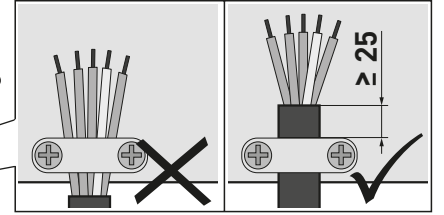

1

2 (2x)

3



7

A B E



1

2

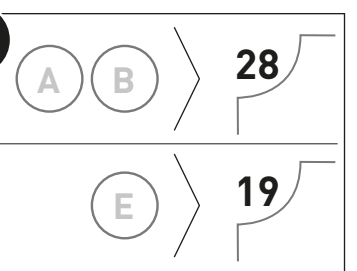

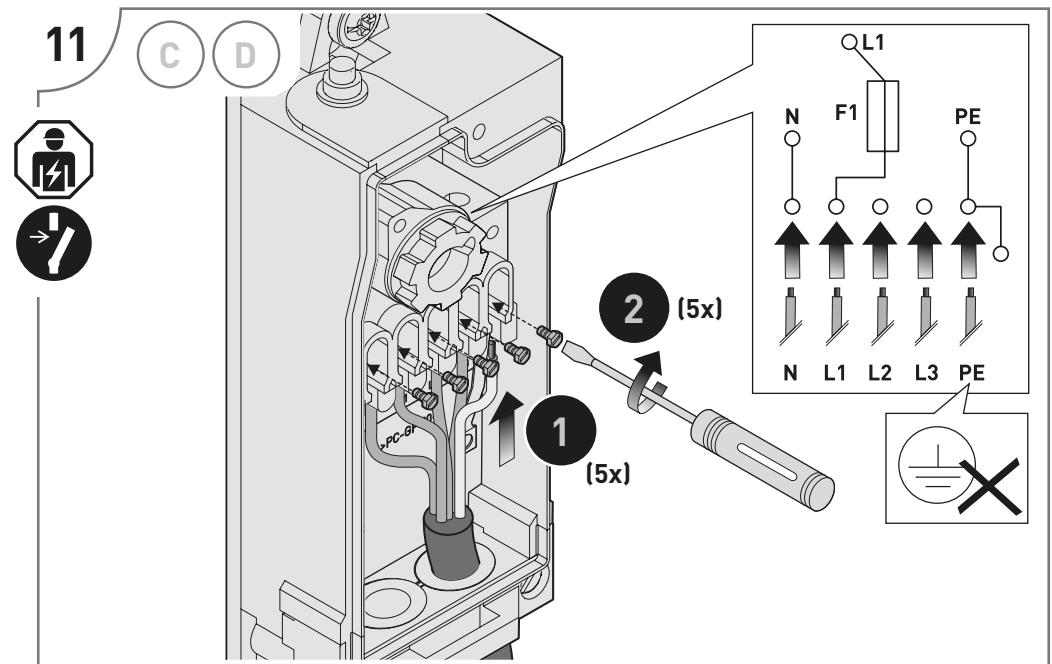
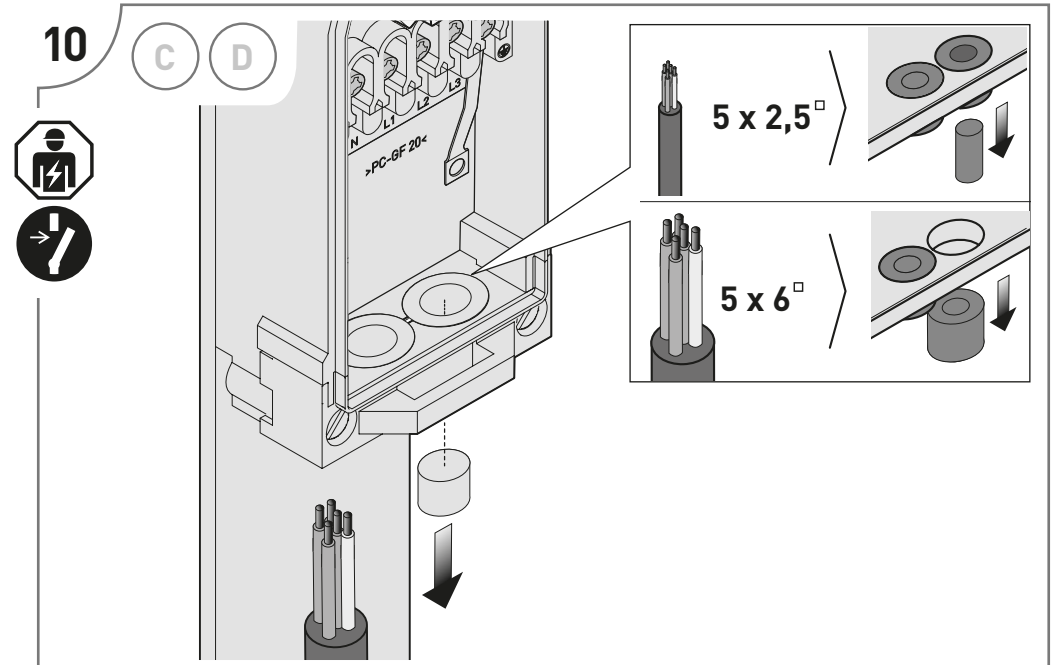
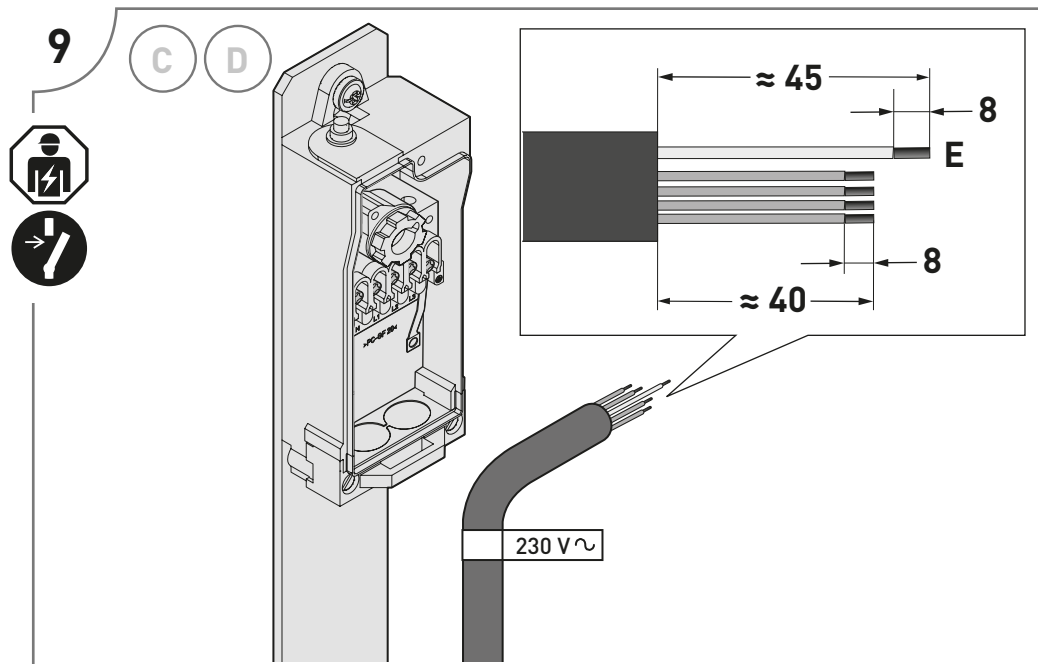
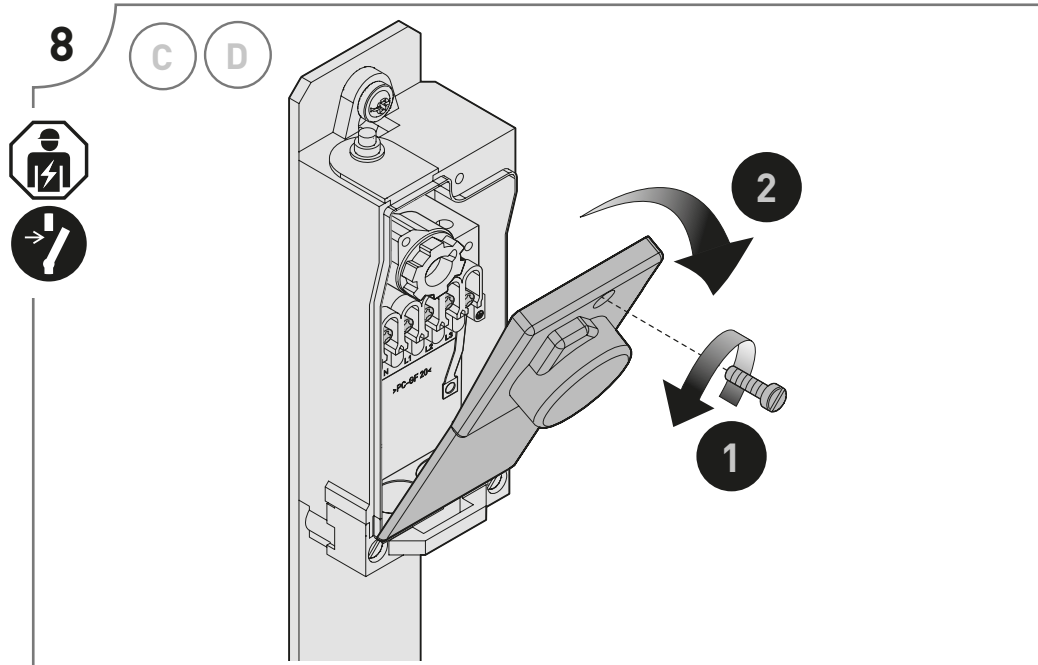

12

C D

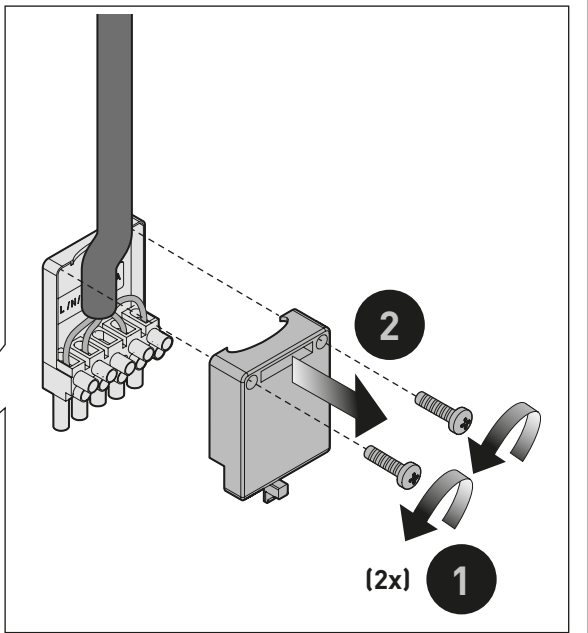
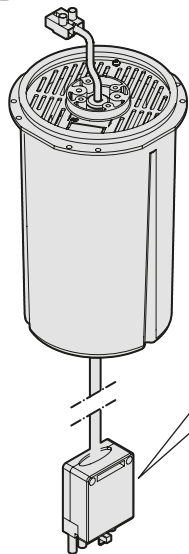

(2x) 1

15

C D

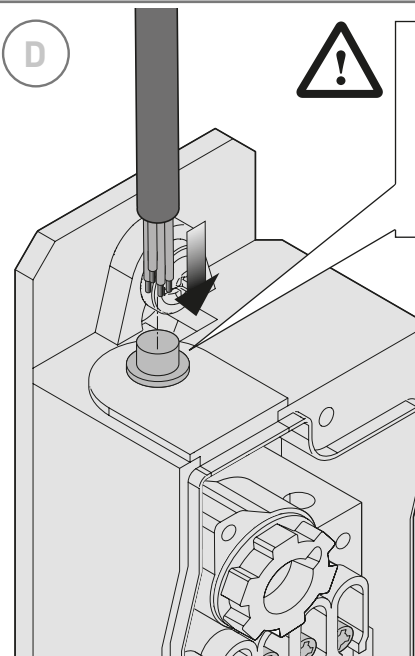
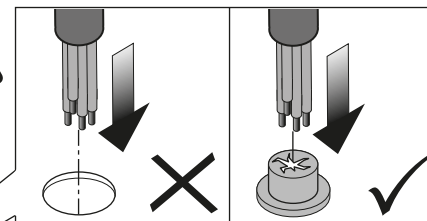

13

C D

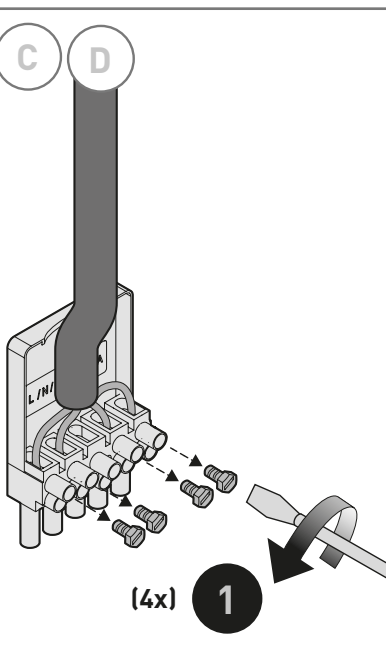

(4x) 1

14

C D

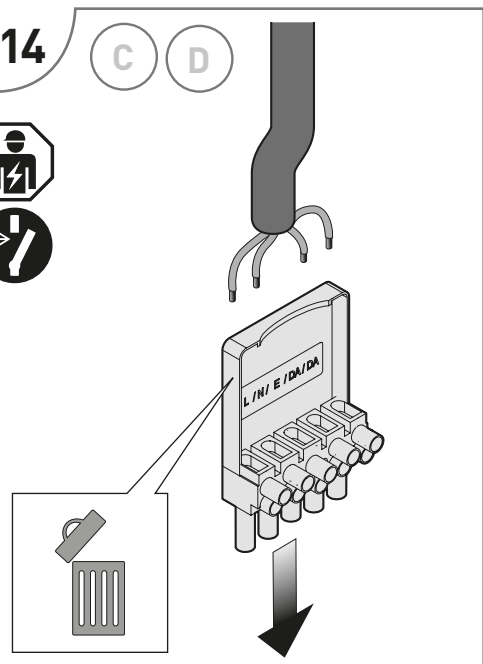

16

C D

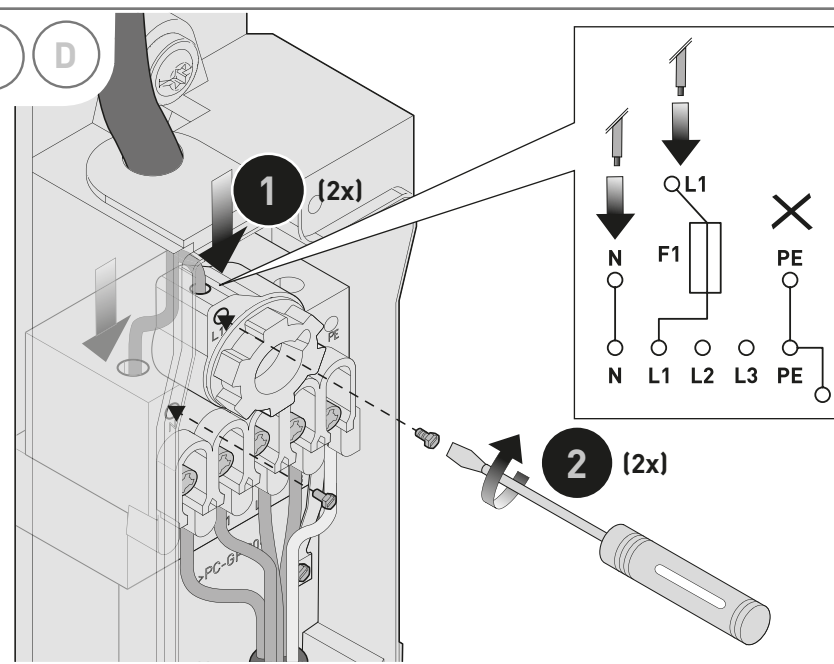

1 (2x)

2 (2x)

17

C D

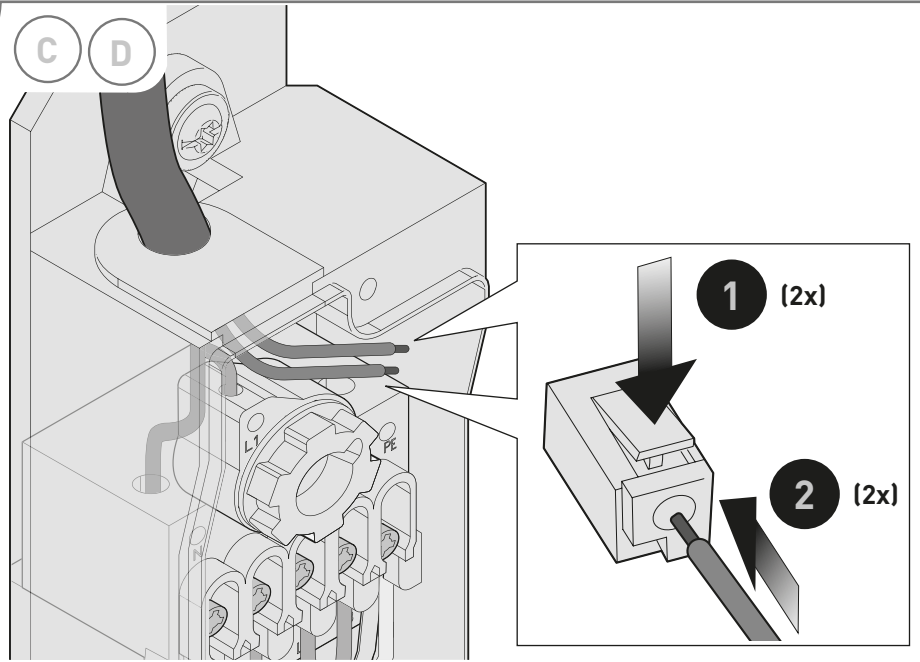

18

C D

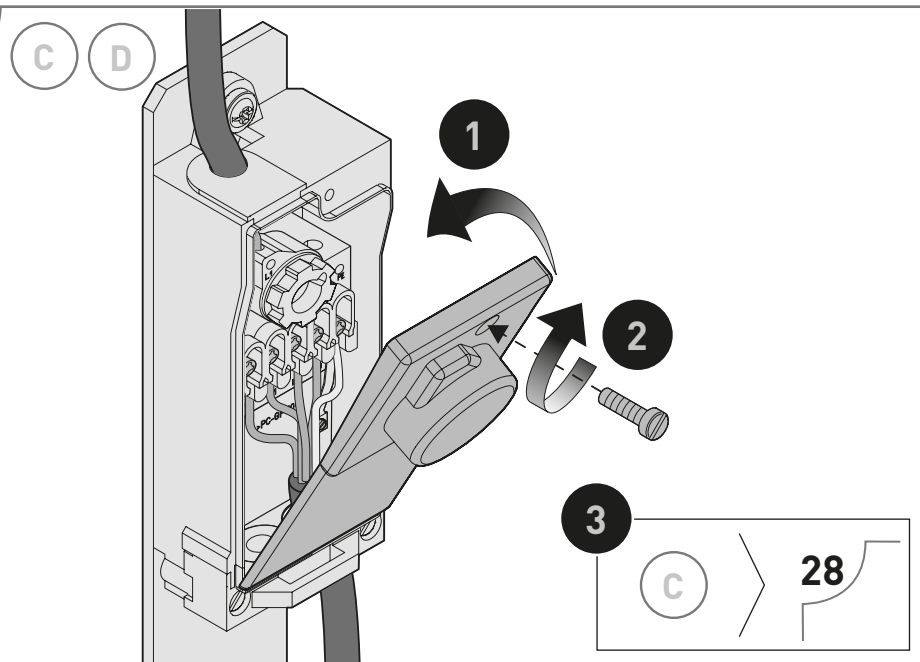

19

D E

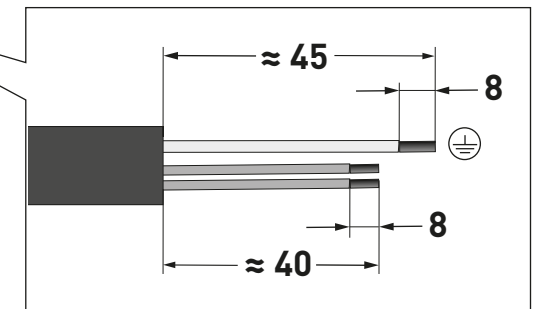
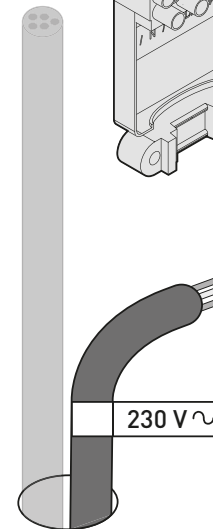
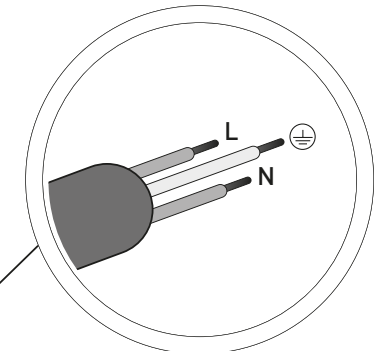
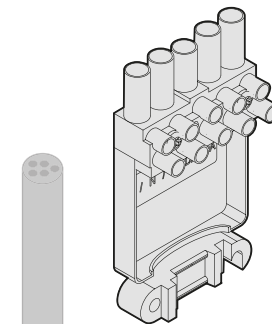
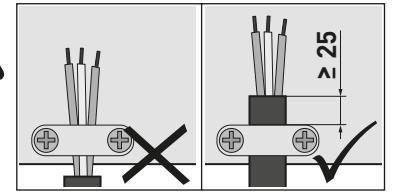
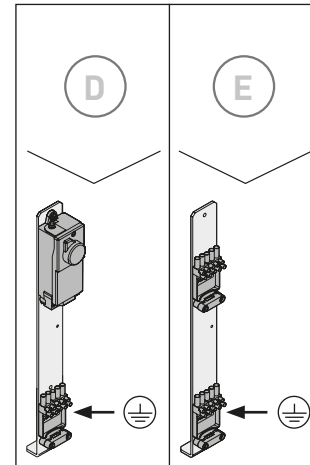

20

D E

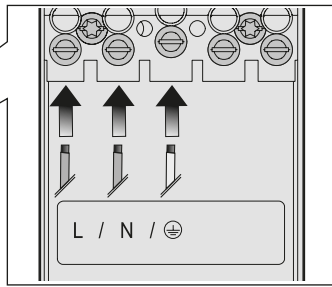

1 (3x)

2 (3x)

21

D E

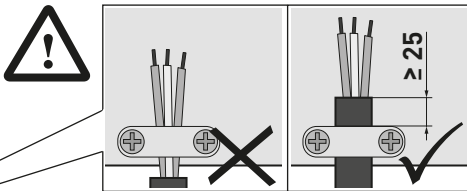

1

2 (2x)

22

D E

1

2

D E

28



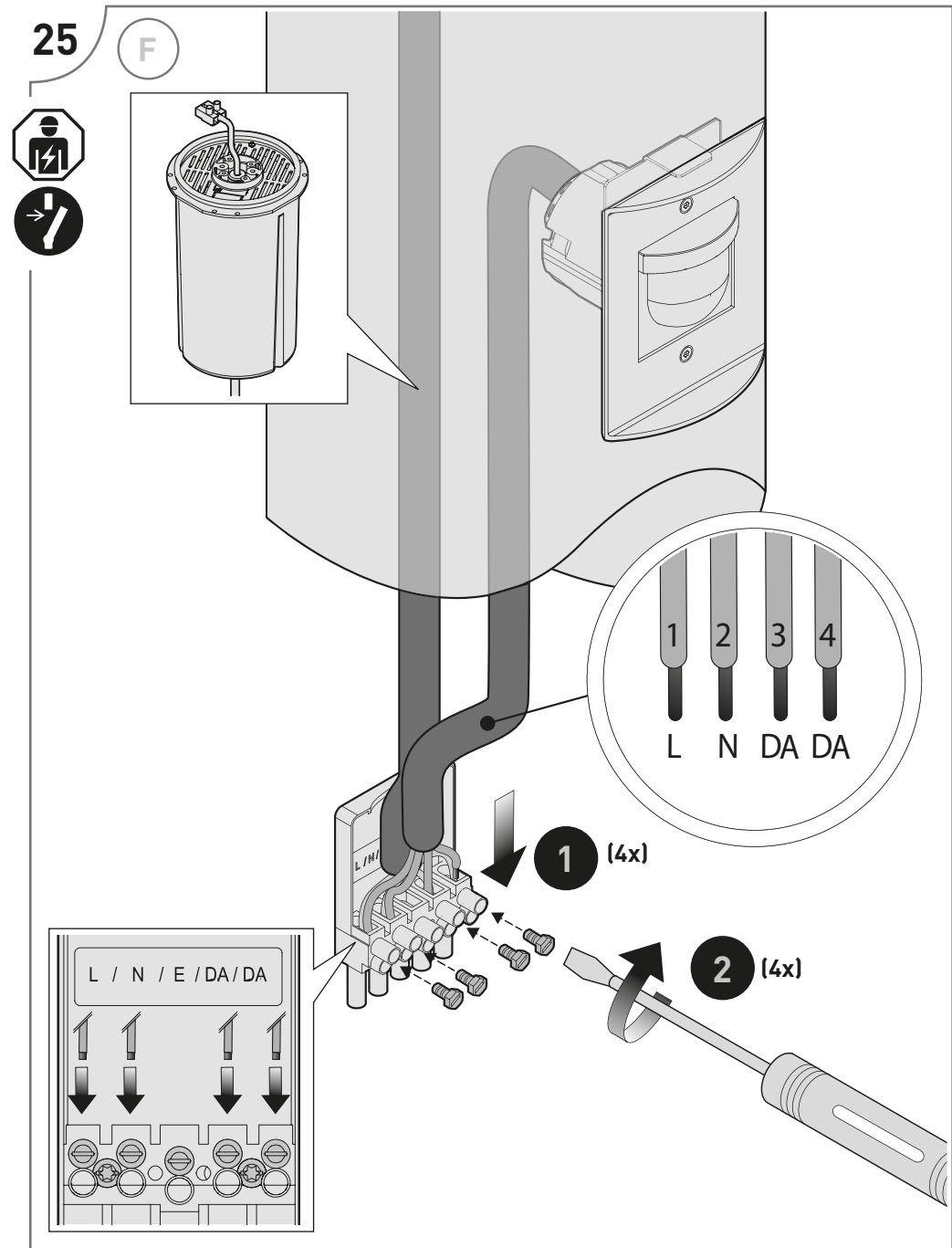
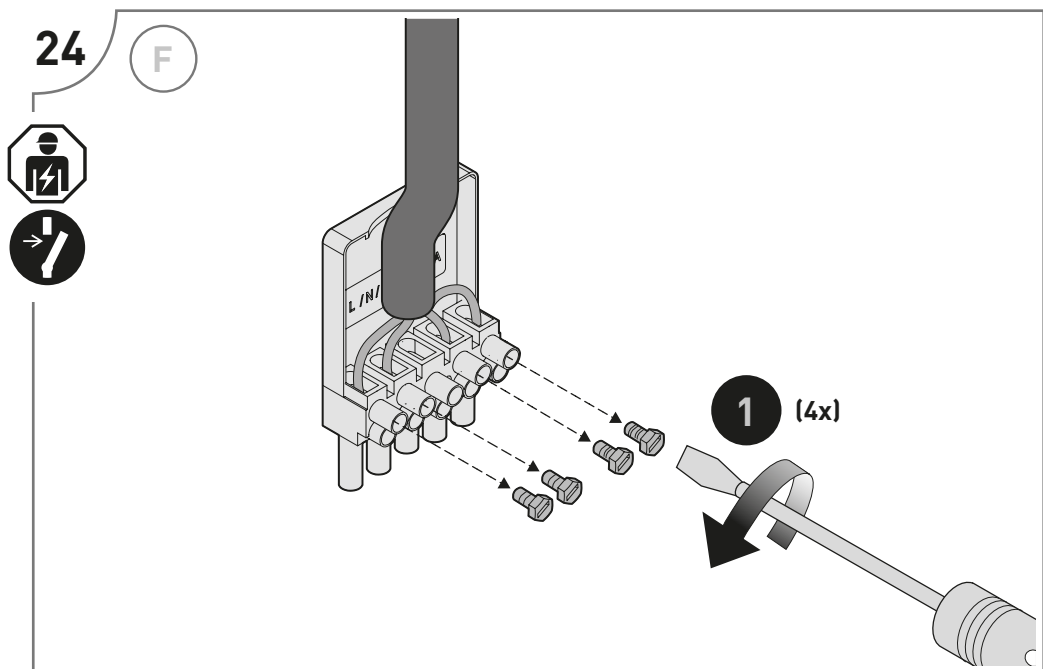
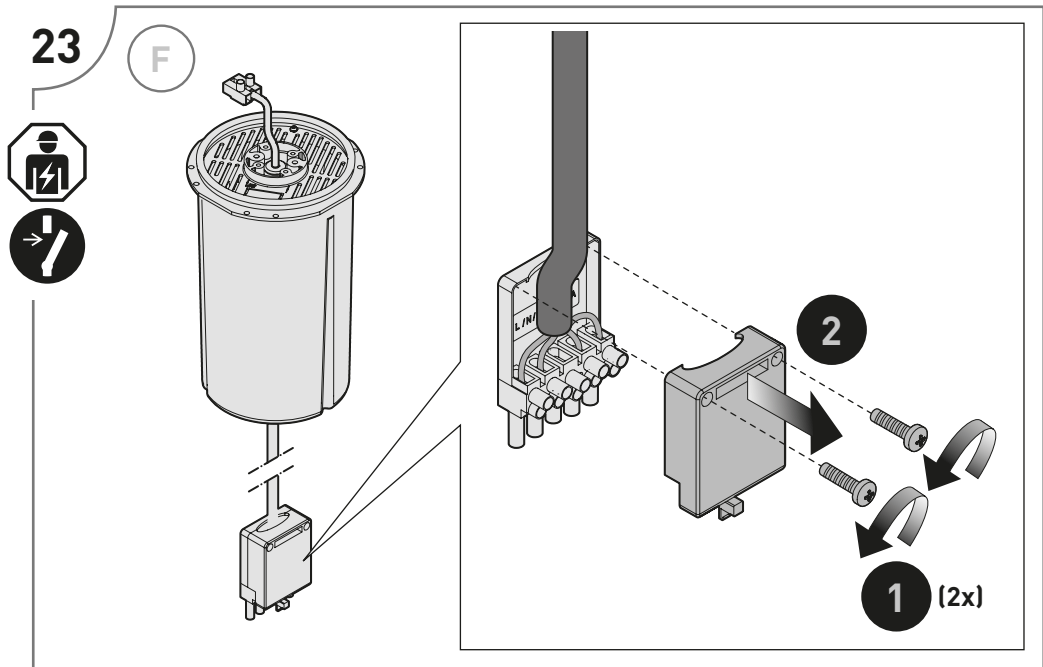

26

F

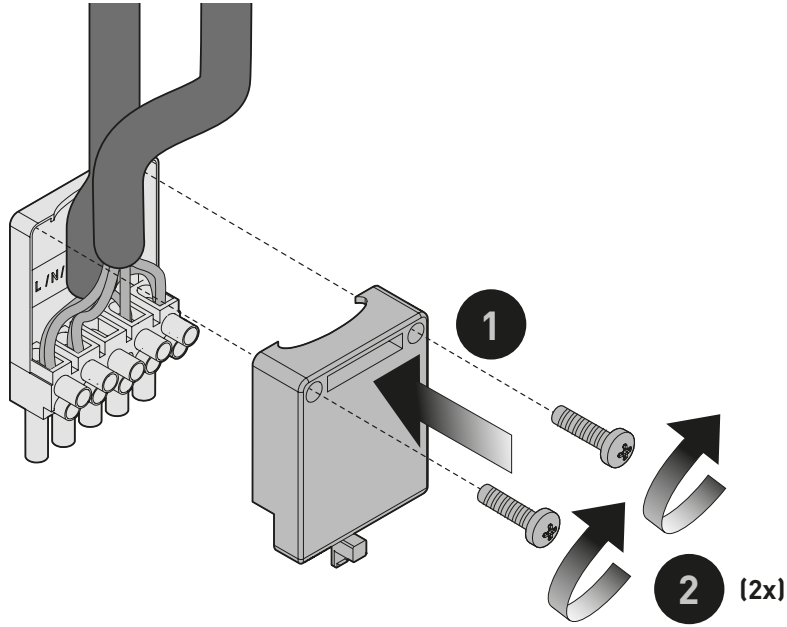

27

F

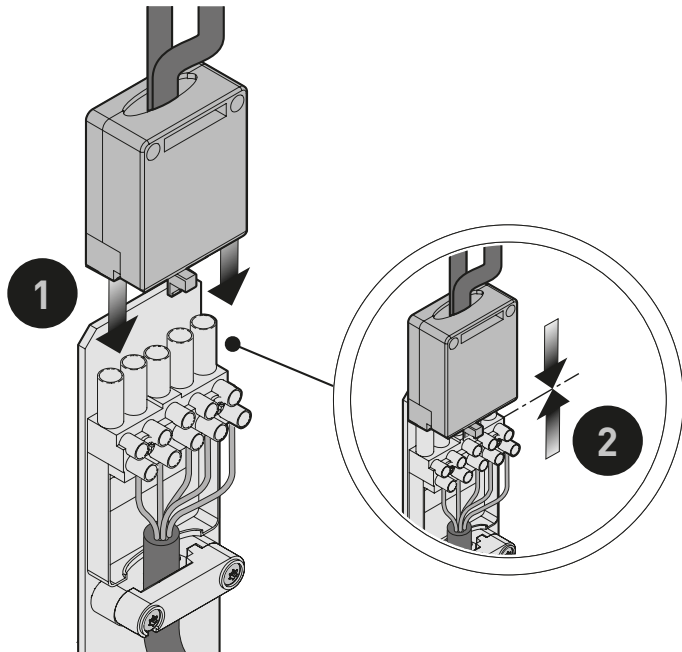

i

F

1

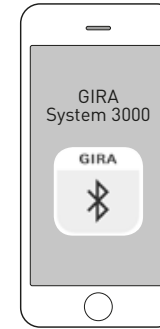

Download on the App Store



GET IT ON Google play

2

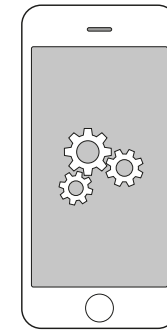

3

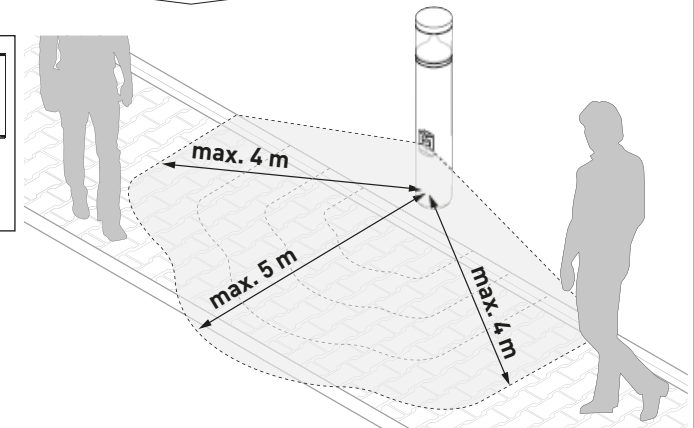
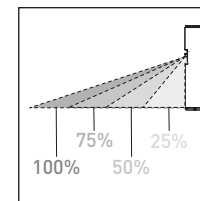

28

A B C D E F

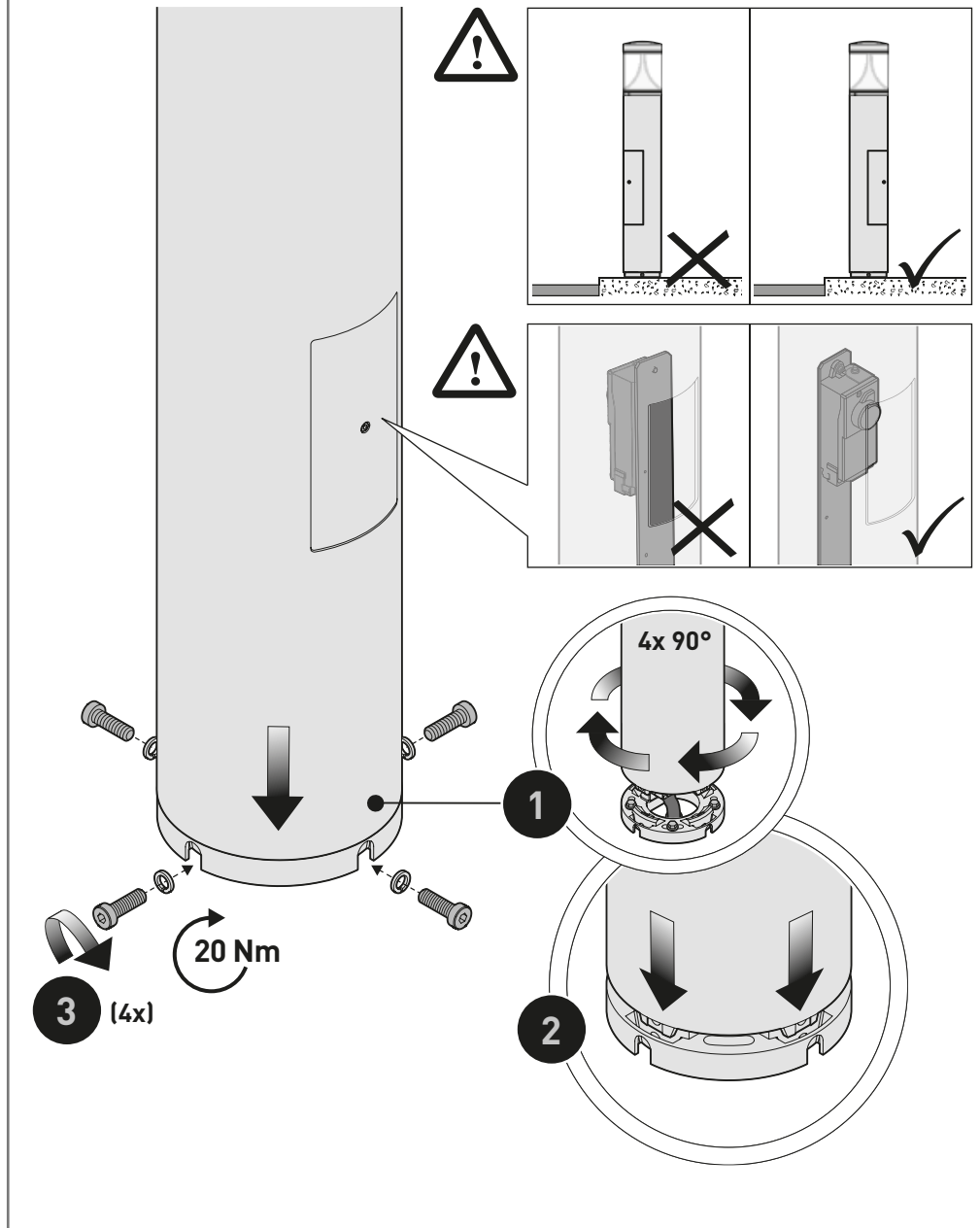

29

A B C D E F

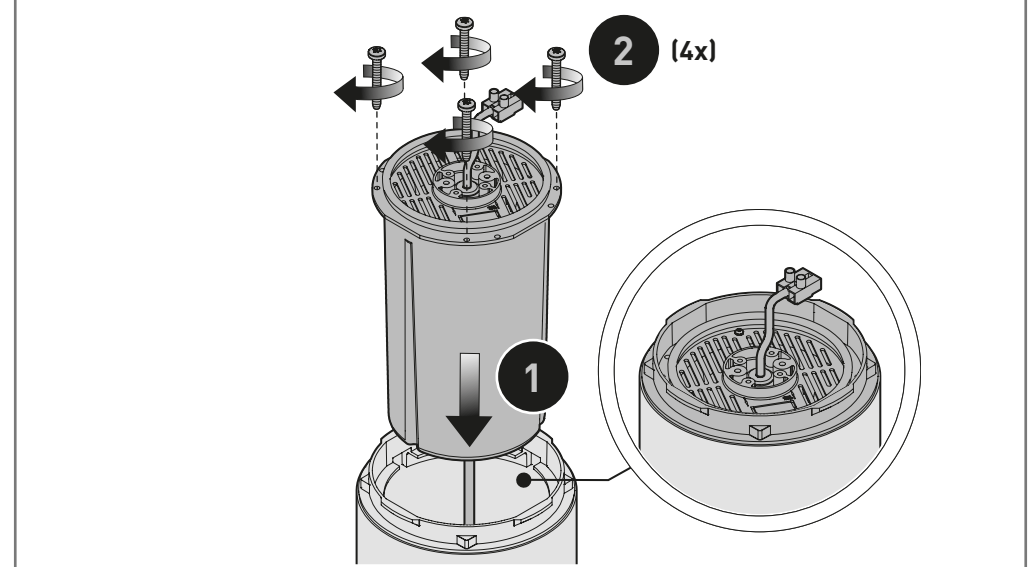

i

A B C D E F

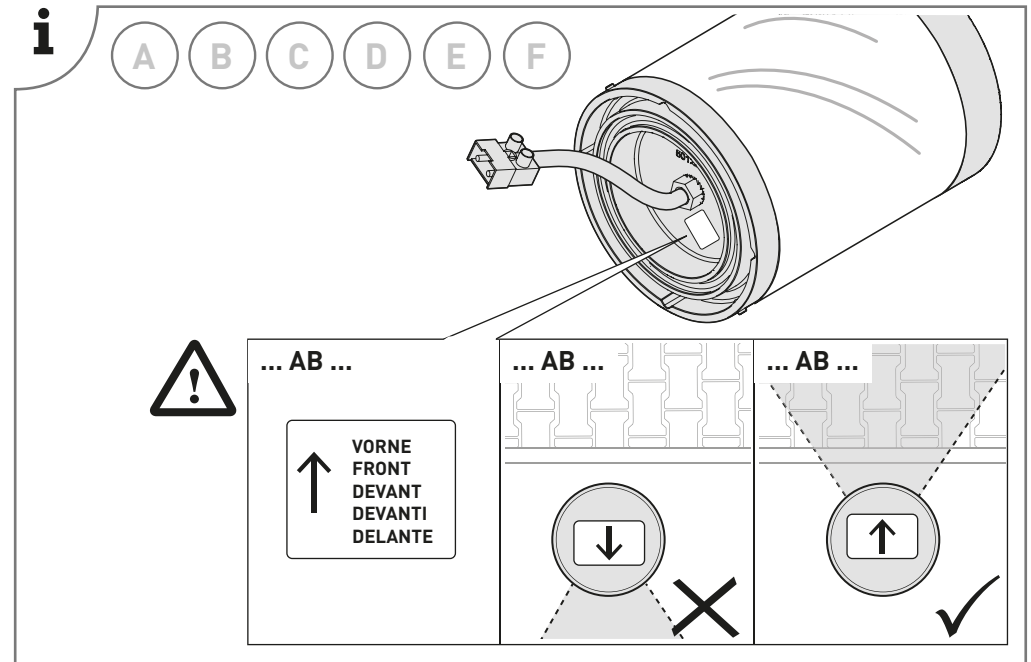

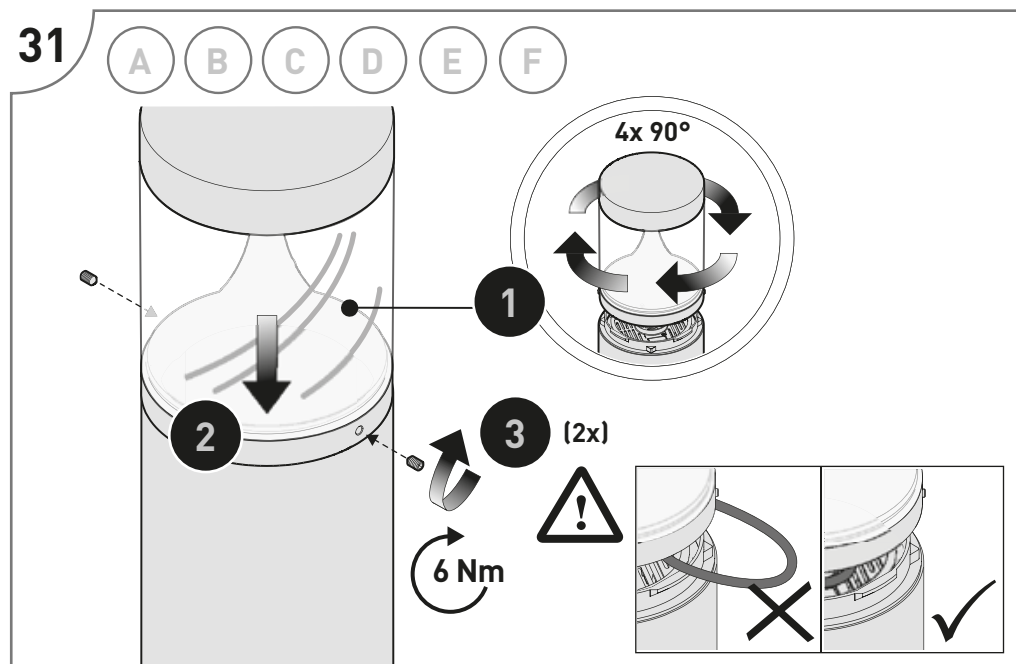
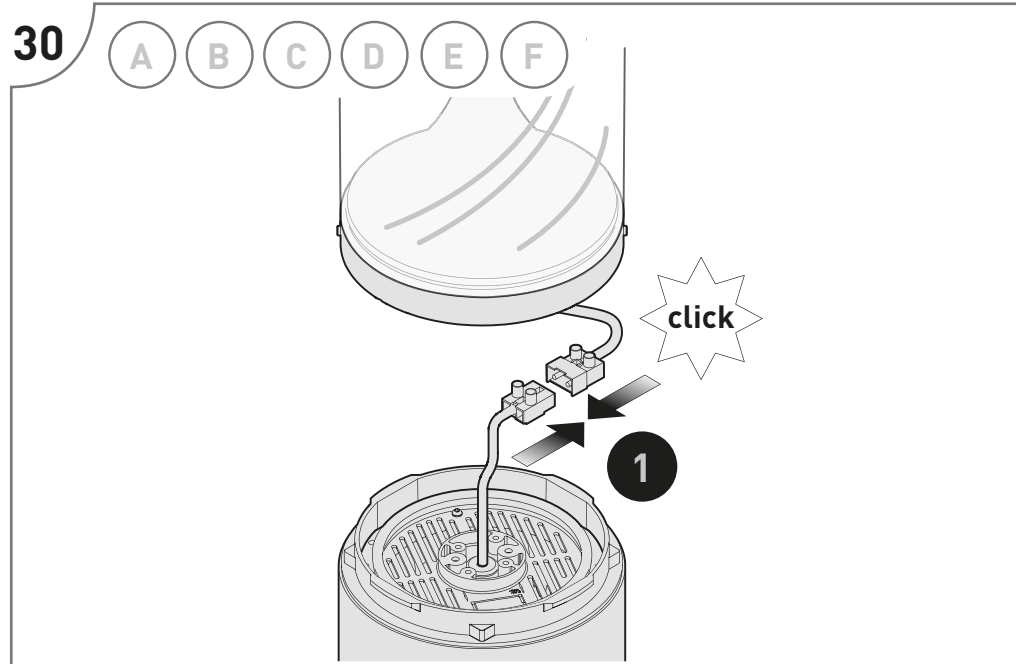

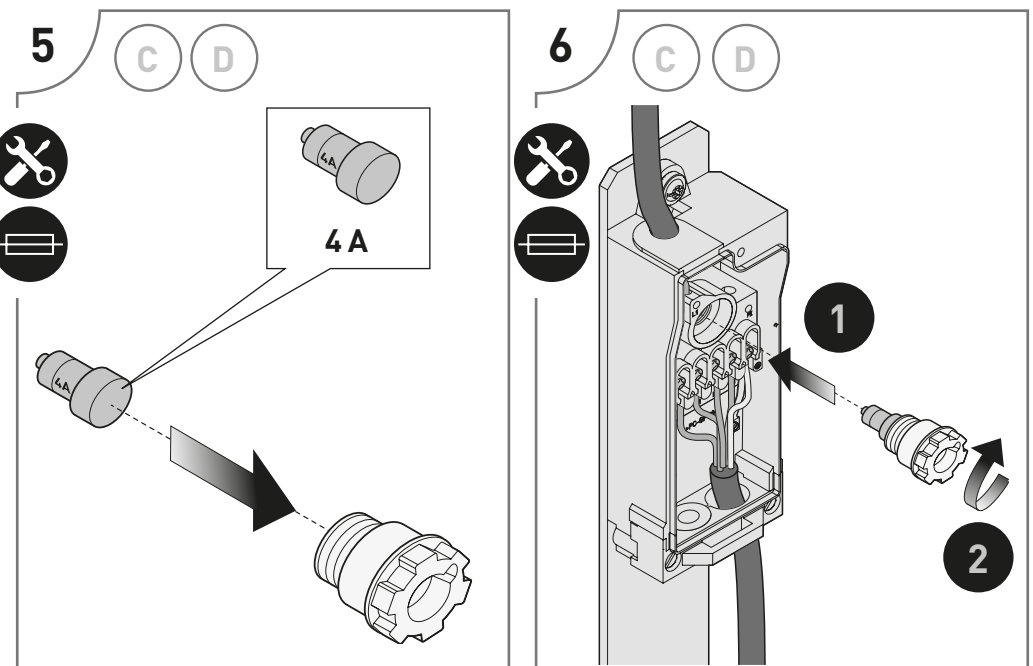
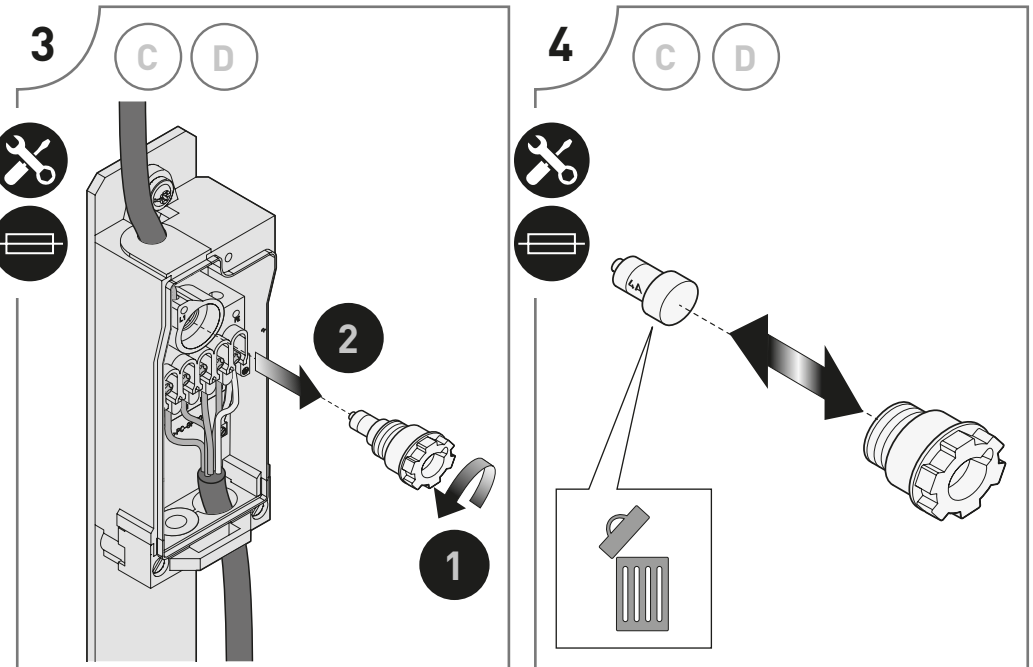
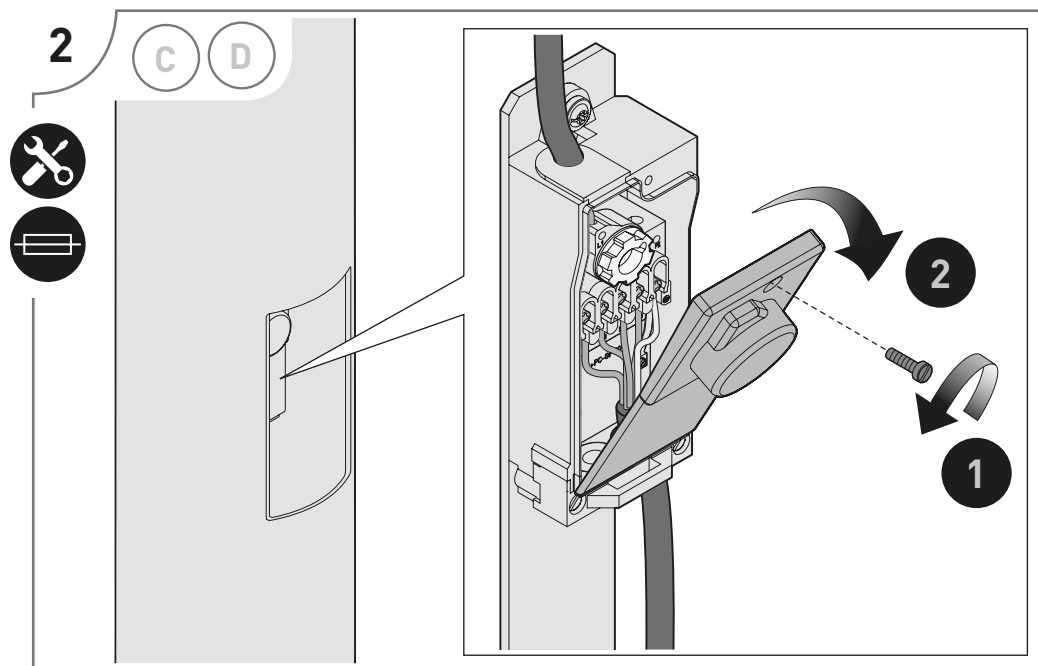
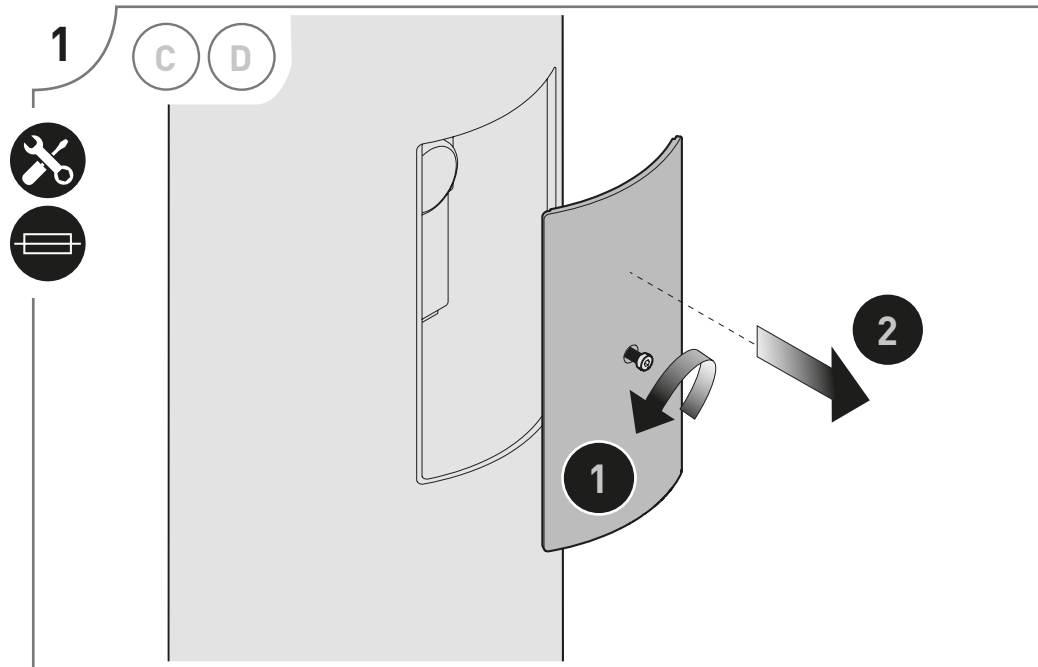

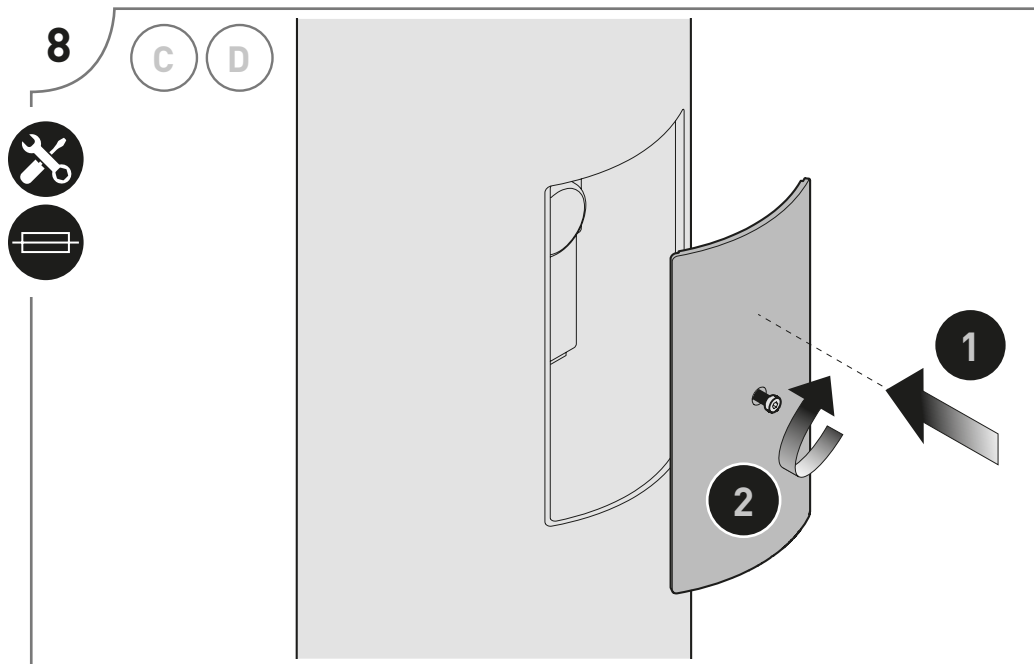
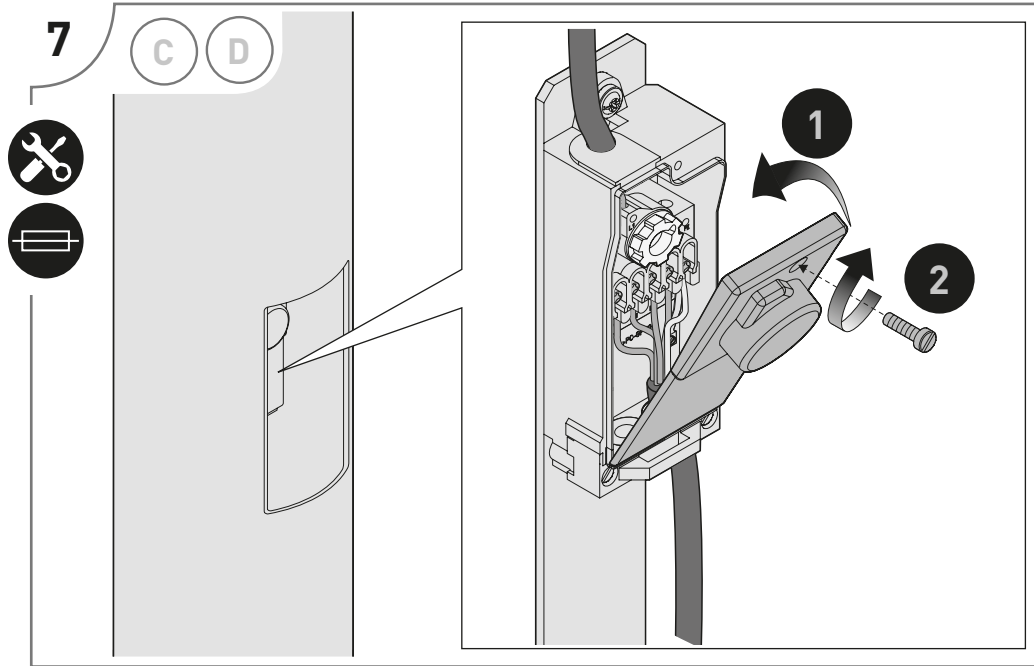



**TRILUX**  
SIMPLIFY YOUR LIGHT

TRILUX GmbH & Co. KG

Heidestraße  
D-59759 Arnsberg  
+49 2932 301-0  
info@trilux.de  
www.trilux.com