



Institute for Atomic and Molecular Physics  
Kruislaan 407 Amsterdam  
The Netherlands

## **Explosion Release Control IV, AMOLF RH-EX**

Initiator: Gorter Bouwprodukten BV  
Executor: FOM-AMOLF, Afdeling Mechanisch ontwerp  
Date: 12-07-2006

Contents	page
1 <b>Introduction</b>	2
2 <b>Design</b>	2
3 <b>Determination of the opening pressure</b>	5
3.1 General	5
3.2 Test method according to prEN14797	6
3.3 Opening force – test set-up	7
4 <b>Tests and results</b>	8
5 <b>Further tests and requirements</b>	9
6 <b>Conclusions and recommendations</b>	10

## 1 Introduction

Gorter Bouwproducten BV invited FOM-AMOLF to design, prototype and test an Explosion Release Control suitable for standard Gorter RH Hatches.

As a result from earlier studies; 'Innovatie van een veiligheidssluiting (Innovation of a safety latch) I, II & III,' following design of an explosion release control is presented. The prototype has been build and tested. This report describes the design and testing in detail.

## 2 Design

The new design is meant to replace the old design Gorter explosion release control (150x70x18 mm) that is operating with a breaking pin. The old design is a modification from the normal catch that is mounted in normal roof access hatches. The explosion release control will always be combined with a standard cylinder lock with dead bolt and slam lock.

The present design has to be interchangeable with the standard normal catch. The opening force is specified at 100 kgf (980 N) (see **3**)

A stainless steel sheet continuous hinge 40x1.5 mm (Pinet-42-1-3301) has one side mounted to a 1.5 mm stainless steel sheet mounting plate, 155x62 mm, with its short sides folded up 16 mm. The moving part of the hinge functions as catch in which both slam lock and dead bolt engage. On top of the moving hinge part, a round 5mm stainless steel shaft is welded. Both ends of the shaft are fitted with tension springs, 2 on each side. The mounting plate is also fitted with a Ø 5 mm shaft to hold the other ends of the springs in the same manner. The whole is encased in 0.5 mm stainless steel sheet housing.



Fig. 2.1 Explosion release control (catch)

The catch is held into its closed position by the tension of the springs. To open it, the hinge has to rotate about 75 degrees; this movement will increase the tension of the springs. The chosen dimensions of the springs result in a maximum tension force at minimum building space ('thickness' in this particular case)

Both slam lock and dead bolt engage the same catch in the form of the hinge. The bolts of a standard cylinder lock are placed in different positions as well have different dimensions. The dead bolt is longer and situated lower than the slam lock. Therefore a 2 mm thick stainless steel sheet is welded onto the hinge at this position. The different position at which the strike is actuated with respect to the rotation point of the hinge results in a different opening force. When locked (i.e. with engaged dead bolt) the opening force will be 25% higher than in the non-locked position (i.e. only the slam lock engaged)

The opening force is down scalable; two or four springs can be mounted, and springs with smaller wire diameters can be mounted. The design has been optimized to a maximum reproducible opening force into the specified housing construction.

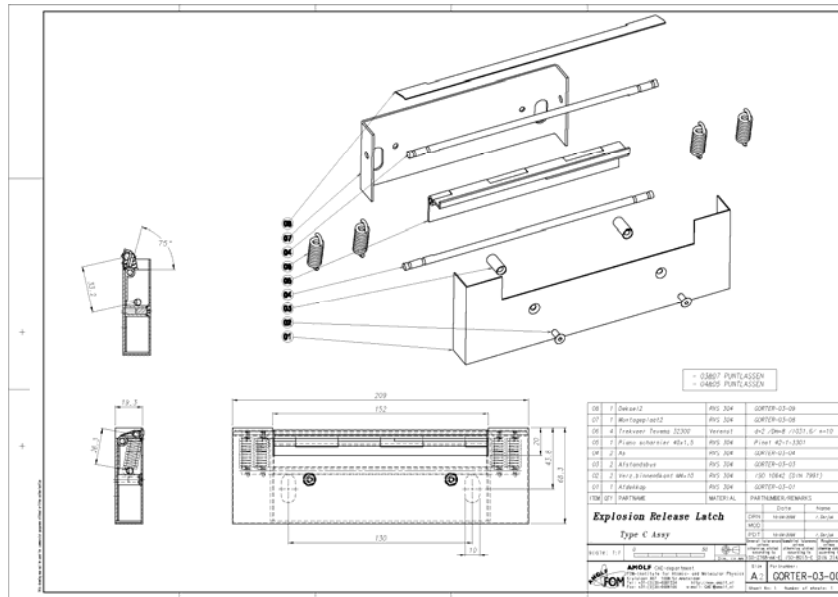

Fig. 2.2 Assembly drawing

By optimization of the design, the spring force with accompanying spring is determined.

To fully open the strike, the hinge has to travel over an angle of 75 degrees. The spring is tensioned 11 mm from the hinges rotation centre. So the spring is tensioned over a range of 7 mm when opened. The specified opening force is approx. 1000 N => 4 springs are used,  $100/4 = 250 \text{ N @ } 7 \text{ mm}$ . Resulting from the specifications above, a tension spring has been chosen from the spring manufacturer's (Tevema) tables;

Tevema Tension spring art. no. T32300, wire thickness 2.00, diameter 8.00, untensioned length 31.6 mm, 220 N at 5.9 mm,  $C=31.8 \text{ N/mm}$ . ([www.tevema.com](http://www.tevema.com))

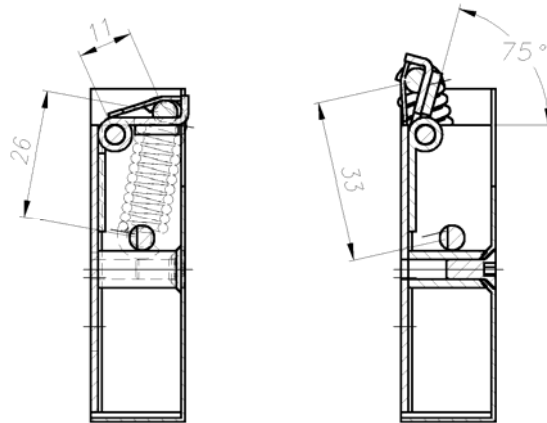

Fig. 2.3 Operation schematics

When the catch is opened, at a deflection of 7 mm, the spring tension =  $220 + 31.8 = 251.8 \text{ N}$ . The theoretical opening force amounts to  $(4 \times 251.8 = 1007 \text{ N})$ . The efficiency and friction of the mechanism are neglected.

### 3 Determination of the opening pressure

#### 3.1 General

The pressure value at which an explosion release control should open is not specified in NEN 6702 or prEN14797.

PrnEN 14797: the static activation pressure shall be stated including the tolerance range by the manufacturer.

In theory a hatch cover without any opening resistance will be most effective. This cannot be realized (1) for technical reasons, (2) pressure differences in a building for example caused by wind pressure must be taken into account and (3) the fact that unauthorized personal can open the hatch cover with the same force from the outside.

THE NFPA 68 Guide for Venting and Deflagrations: 2002 Edition recommends a release pressure between 0.14 psi and 0.21 psi. (965 N/m<sup>2</sup> up to 1448 N/m<sup>2</sup>)

Based on these considerations an opening force at the opening side of a hinged hatch has been chosen of approximately 100 kgf, i.e. 980 N.

#### 3.2 Test method according to prEN14797

The tests are conducted in accordance with prEN14797, Art. 7.2.3; 'Mechanical test method. By applying continuously increasing mechanical forces on the venting element, the activation of the explosion release control is effected. The direction of the force is normal to the venting element. The point of application of the force depends on the design of the explosion release control.'

Since the tested hatch is hinged, and the manufacturer specifies an opening force at the opening end of the hatch, the point of application of the force as mentioned above is direct at the position of the lock & explosion release control.

A hinged hatch is held at one side by hinges at the other by the latch (explosion release control). This means that the latch should release the hatch at a force equivalent to half the force on the hatch at the critical pressure.

The measured opening force at the latch is 960 N (see **5**). The force acting at the middle of the hatch = 960 N x 2 = 1920 N.

Standard dimensions according to Gorter Specification RH-A and RH-S and their static activation pressures:

Dimensions (mm)	Area (m <sup>2</sup> )	S.A.Pressure (N/m <sup>2</sup> ) (1920 N / Area)	
		4 springs	2 springs
1000x1500	1.500	1280	640
1220x1220	1.489	1289	645
1370x760	1.041	1844	922
915x915	0.837	2293	1147
915x760	0.695	2761	1380

The static opening pressures of the 1000x1500 and 1220x1220 are within the NFPA68 specifications (965 N/m<sup>2</sup> up to 1448 N/m<sup>2</sup>). The 1370x760, 915x915 and 915x760 have higher static opening pressures. When fitted with two instead of four springs the opening pressure is divided by two (pressure between brackets) and within the NFPA68 specifications.

When the explosion release control is fitted with four springs, it meets the demands in terms of access security (opening from the outside) of all hatches in the products range.

When fitted with two springs, it meets the demands in terms of static activation pressure according to NFPA68, for all hatches in the range.

### 3.3. Opening force - test set-up

To measure the opening force following test stand has been set up. A complete roof hatch construction was supplied by Gortor (915x915cm). The curb was clamped onto a 300kg heavy steel plate. The tackle of an overhanging manual hoist is connected to the load cell that is hooked up to the cover with a special aluminum attachment.

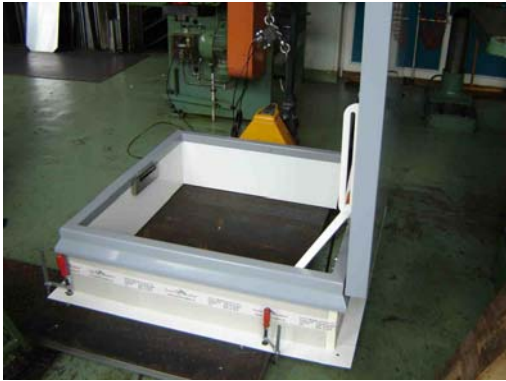

Fig.4.1 Door fixed to floor (steel plate)



Fig.4.2 Load cell

When the hoist is operated an opening force is applied to the door. The force is measured by the load cell provided with a digital readout.

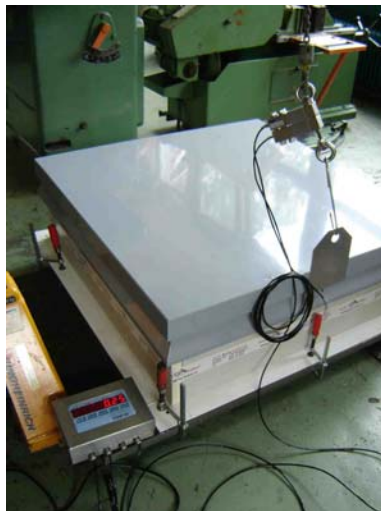

Fig.4.3 Test set-up



Fig.4.4 Opening attempt by hand

#### 4 Tests and results

Measurements were carried out using a Zemic H8C-C3-2.0t-4B Class 3 load cell, with an absolute accuracy of +/- 0.5 kg. During the measurements the hoist was manually operated and the force was gradually increased until the explosion release control opened. The opening force in kg was read out from a digital display. The force increased linearly until release. Each value at which the explosion release control opened was recorded. The test was repeated 10 times. Two series of tests were conducted, one series of 10 with activated dead bolt and one series of 10 with non-activated dead bolt.

Test#	Slam latch and activated dead bolt Force (Max.) kgf.	Slam latch only Force (Max.) kgf.
1	95.0	76.0
2	97.0	75.0
3	94.5	67.0
4	95.5	70.5
5	95.5	73.0
6	98.5	70.5
7	97.0	71.5
8	94.5	73.5
9	97.5	73.5
10	93.0	70.0

The average measured value turned out to be 96 kgf  $\pm$ 1.5 kgf (= absolute precision and readout resolution combined). The measuring errors introduced by the system, measuring device and procedure were neglected (within 10 %). The required specification of a reproducible force around 100 kgf is therefore obtained. The difference between the practical and theoretical opening strength (mentioned in 2.) is explained by the extra opening force of the spring-assisted door opening system.



## 5 Further tests and requirements

### NEN 6702

Specifies a door weight  $< 25 \text{ kg per m}^2$ . **The tested door cover did not exceed that weight.** According to weight table in Specification RH-A & RH-S.

Confirms the need to calculate the specific venting surface in a building. A calculating method is not specified.

### The NFPA Guide 68: 2003

The door, or parts of it, may not become projectiles in case of an explosion.

Doors must be sufficiently anchored to the building.

The place of the relieving openings must be chosen in a way that personnel can not be exposed to the explosion force or material ejection.

Loads (by for example snow) may not disturb the functioning.

Door construction must be maintained properly.

The Guide gives methods for calculating the dimension of the required relieving openings in the building.

### prEN14797:

#### Art. 7.3.3. - Mechanical strength test:

Gorter doors have been pressure tested by the Stichting Kwaliteit Gevelbouw (SKG). **In SKG Report No. 04.1001, dated 23 December 2004, is determined that the construction withstands  $> \pm 3000 \text{ Pa}$  without any damage to the construction. This test was carried out according to NEN 3660.**

#### Art. 7.3.2.1. - Venting efficiency calculation:

Hinged doors show a lower venting efficiency than venting devices regarded as inertia free (e.g. rupture foil). A direct determination method of the venting efficiency is given by comparison of an inertia free device with a hinged door vent. **At the moment there are no test data or calculations available.**

#### Art. 7.3.2.2.3 - Inertia greater than $10 \text{ kg/m}^2$

Inertia will influence the venting efficiency. A comparison method is given for covers with inertia greater than  $10 \text{ kg/m}^2$ , this method is similar to article 7.3.2.1. **At the moment there are no test data or calculations available.**

#### Art. 7.4. - Leak testing

Only if required by the purchaser or a notified body.

In SKG Report No. 04.1001 an air loss of  $4,70 \text{ m}^3/\text{hm}^1$  is determined at a pressure of 650 Pa. The test was carried out according to EN 1026.

## 6 Conclusions and recommendations

The testing of the laboratory build prototype of the explosion release control was successful.

Further test procedures have to be carried out according to prEN 14797 - Art. 7.3.2.1. and Art. 7.3.2.2.3.

Explosion release controls have to be tested according to prEN 14797, Art. 7.2.3. and Art. 7.2.5.2. to ascertain that they will function in conformity with the tested prototype.

The functioning of the mechanism is reproducible.

The goals and specifications given by the initiator are obtained.

I. Cerjak  
- Mechanical engineer –

Prof. Dr. P.G. Kistemaker  
- Advisor –

Approval:  
Gorter Bouwprodukten BV  
P. Hoogerdijk  
- Director -

### Sources:

- NEN-EN 14797:2003 Explosion Venting Devices
- Richtlijn EG/94/9:1994, bijlagen I t/m XI
- NEN 6702: 2001, artikel 9.3 en toelichting
- TNO Prins Maurits Laboratorium: 'Gas Explosions'en 'Blast research'
- Drukontlasting van gasexplosies in stookruimten
- Chapter 5 and 6 of NFPA Guide 68: 2002 (authority in the US)
- Gorter Specification Metal Roof Acces Hatch, RH-A and S