

NEU Drainagerinne 100/6VD



GFK-Längsstabrost anthrazit

GFK-Längsstabrost hellgrau



V2A-Designlochrost



Pressgitterrost MW 30/30



Pressgitterrost MW 30/10



Kunststoffrost



V2A-Längsstabrost

Technische Daten

Drainagerinne 100/6VD

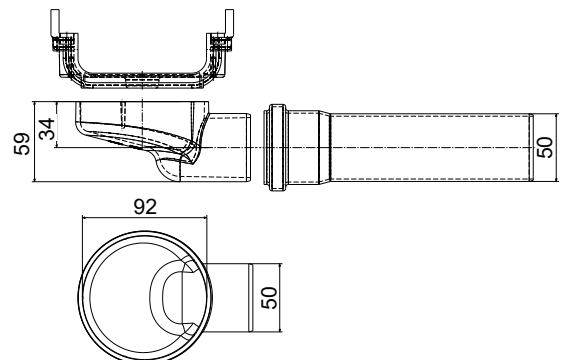
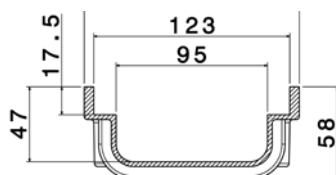

NEU: Drainagerinne 100/6VD



Technische Daten

Drainagerinne 100/6VD

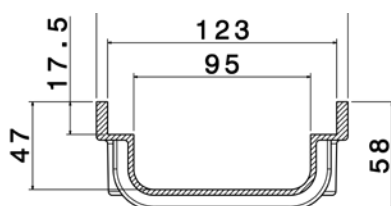

Vorteile auf einen Blick:

- Aus glasfaserverstärktem Polyester (GFK)
- Keine Korrosion
- Witterungsbeständig
- Optisch sehr ansprechende Entwässerung
- Frost- und tausalzbeständig
- Robust und extrem bruchfest
- Begehbar und rollstuhlbefahrbar
- Leichte Reinigung und Montage
- Einfache Steckverbindung durch Sicherheitsdichtungsfalz