

WICSLIDE 160

Hebe-/Schiebesysteme

Lifting/sliding systems

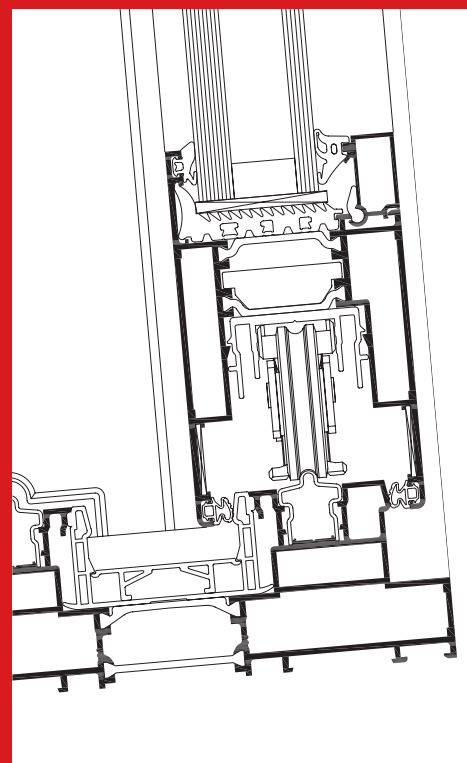

Programm 01.2016
Product range



Die in dieser Dokumentation enthaltenen Daten und Hinweise entsprechen den uns bekannten Informationen zum Zeitpunkt der Drucklegung. Eine Haftung für die hier enthaltenen Informationen ist ausgeschlossen, es sei denn, die Fehler beruhen auf Vorsatz oder grober Fahrlässigkeit seitens unseres Unternehmens.

Die in den Unterlagen dargestellten und beschriebenen Produkte und Anwendungen sind für Fachunternehmen ausgelegt. Sämtliche Beschreibungen erfolgen als Serviceleistung ohne Anerkennung von Rechtspflichten und entbinden nicht von eigener Prüfung bei der Verwendung für Zwecke des Anwenders. Branchenübliche Fachkenntnisse sowie Kenntnis des aktuellen gültigen Standes der Technik werden als bekannt vorausgesetzt und daher nicht gesondert beschrieben oder erläutert.

Die Benutzung des Markenzeichens WICONA® ist nur zulässig, sofern ausschließlich die in den jeweils gültigen WICONA-Profilprogrammen aufgenommenen Konstruktionsteile (Profile, Zubehör und Beschläge) verwendet werden. Die Echtheit der Artikel bzw. Teile und die Einheit der Konstruktion ist erkennbar durch die entsprechende Kennzeichnung bei diesen Teilen. Von Sapa Building Systems entwickelte und geprüfte WICONA-Systeme für Fassaden, Fenster und Türen erhalten mit entsprechenden Prüfungen und Prüfzeugnissen durch anerkannte Institute ihre endgültige Bestätigung. Für jeden verarbeitenden Fachbetrieb sind diese Prüfzeugnisse und Dokumentationen verpflichtende Arbeitsrichtlinien. Bei festgestellten Mängeln, die an WICONA Fassaden, -Fenstern und -Türen sichtbar werden, weil systemfremde Teile verwendet wurden, wird in diesen Fällen jede Haftung durch Sapa Building Systems ausgeschlossen. Desweiteren verlieren die attestierte Prüfzeugnisse für diese Elemente ihre Gültigkeit. Bitte beachten Sie auch die „Wichtigen Hinweise“ im Vorspann unserer Profilprogramme und Verarbeitungsrichtlinien.

Sapa Building Systems

® = eingetragene Markenzeichen
Sapa Building Systems

The data and instructions contained in this documentation correspond to the information known to us at the time of printing. There is no liability on our part for the information contained herein, unless the errors are deliberate on our part or attributable to gross negligence by our company.

The products and applications shown and described in these documents are designed for specialist companies. All descriptions are provided as a service, without admitting legal responsibility, and do not release the user from the need to check that a product or application is suitable for the particular purpose envisaged. Specialist knowledge customary in this branch of business and awareness of the latest technology are assumed and consequently are not separately described or explained.

Use of the trademark WICONA® is permitted only if the structural parts included in the applicable WICONA profile programmes (profiles, accessories and fittings) are exclusively used. The genuineness of the items or parts and the uniformity of the design is identifiable by the corresponding markings on these parts. WICONA systems developed and tested by Sapa Building Systems for facades, windows and doors are ultimately qualified by the appropriate tests and test certificates from recognised institutes. Each processing company is subject to these test certificates and documentation as mandatory work guideline specifications. Sapa Building Systems is not liable for any defects visible on WICONA facades, windows and doors and attributable to the use of parts not belonging to the system or to a lack of maintenance of these products. The corresponding test certificates also lose their validity for these items. Please also note the "Important indications" in the opening sections of our profile programmes and processing guideline specifications. All our sales are subject to these standard terms of sale and to any particular and specific conditions mentioned in our price lists in force and invoices.

Sapa Building Systems

® = registered trademarks
Sapa Building Systems

1 **Vorspann / Technical Prefix**

Nummernverzeichnis, Wichtige Hinweise, Wichtige Hinweise zum Beschlag, Öffnungsarten, Symbole und Hinweise, Technische Informationen
Numerical index, Important indications, Important indications on hardware, Opening types, Symbols and indications, Technical Information

2 **WICSLIDE 160**

Serienbeschreibung, Profilübersichten, Profile, Anwendungsbeispiele, Glasleistenprofile / Auswahltabellen, Zulässige Flügelgrößen, Beschlägeübersichten
Description of series, Survey of profiles, Profiles, Examples of application, Glazing bead profiles - Selection tables, Admissible sash sizes, Survey of hardware

3 **Profile universell / Profiles universal**

Glasleistenprofile, Fenstersims, Verschiedenes, Laibungsprofil, Abdeckleiste, Zusatzprofile, Eckwinkelprofile
Glazing bead profiles, Window sill, Miscellaneous, Flashing, Cover strip, Additional profiles, Corner angle profiles

4 **Zubehör / Accessories**

Übersicht Zubehör, Dichtungen Meterware, Dichtungen Stückware, Kunststoffprofile, Formstücke, Eckwinkel, Blechteile, Verbinder, Verbindungselemente / Schrauben, Verschiedenes, Schrauben-Tabellen
Survey of accessories, Gaskets, Plastic profiles, Moulded pieces, Corner angles, Metal sheet parts, Butt-joint connectors, Connecting components / screws, Miscellaneous, Screw tables

5 **Beschläge / Hardware**

Beschläge für Hebe-/Schiebesysteme
Hardware for Lifting/sliding systems

6 **Werkzeuge / Tools**

Sägebeilagen, Schablonen, Stanzwerkzeuge, Presstawerkzeuge, Verschiedenes, Hilfsstoffe
Sawing shims, Templates, Punching tools, Crimping tools, Miscellaneous, Auxiliary means

7 **Kompendium / Comprisal**

Statikseiten, Statische Werte, Eckwinkelzuschnitt - Auswahltabellen, Zertifikate
Static pages, Statical values, Cutting corner angle - Selection tables, Certificates

	Seite <i>Page</i>
Nummernverzeichnis <i>Numerical Index</i>	N1
Wichtige Hinweise <i>Important indications</i>	1/3
Wichtige Hinweise zum Beschlag <i>Important indications on hardware</i>	1/11
Öffnungsarten <i>Opening types</i>	1/13
Symbole / Hinweise <i>Symbols / Indications</i>	1/14
Abkürzungsverzeichnis <i>List of abbreviations</i>	1/17

Artikel-Nr. <i>Article-no.</i>	Seite <i>Page</i>	Artikel-Nr. <i>Article-no.</i>	Seite <i>Page</i>	Artikel-Nr. <i>Article-no.</i>	Seite <i>Page</i>	Artikel-Nr. <i>Article-no.</i>	Seite <i>Page</i>	Artikel-Nr. <i>Article-no.</i>	Seite <i>Page</i>
1040001	2/19	3940021	3/14						
1040002	2/23	3940022	3/14						
1040004	2/20	3991001	3/3						
1040010	2/26	3991002	3/3						
1041331	2/27	3991003	3/3						
1041339	2/27	3991004	3/3						
1041344	2/22	3991005	3/3						
1041345	2/16	3991006	3/3						
1041346	2/17	3991007	3/3						
1041347	2/18	3991008	3/3						
1916203	2/25	3991009	3/3						
1940006	2/15	3991010	3/3						
1940019	2/21	3991011	3/3						
1940037	2/24	3991012	3/4						
1940041	2/26	3991013	3/4						
3041173	3/13	3991014	3/4						
3041228	2/28	3991015	3/4						
3041229	3/13	3991264	3/5						
3041300	2/29	3991265	3/5						
3041301	2/29	3991266	3/5						
3041305	2/28	3991267	3/5						
3041306	2/28	3991268	3/5						
3041309	3/13	3991269	3/5						
3041310	3/13	3991270	3/5						
3041312	2/30	3991271	3/5						
3041313	3/13	3991272	3/5						
3041314	2/30	3991273	3/5						
3041315	2/30	3991274	3/5						
3041321	2/30	3991275	3/6						
3041329	3/14	3991276	3/6						
3041330	3/14	3991277	3/6						
3090063	3/8	4000165	3/9						
3090120	3/9	4000166	3/9						
3090121	3/11	4000167	3/10						
3090122	3/11	4000168	3/10						
3090123	3/11	4000170	3/7						
3090161	3/7	4000178	3/9						
3090162	3/7								
3090175	3/14								
3090193	3/12								
3090194	3/12								
3091058	3/12								
3091059	3/12								
3690844	3/8								
3900006	3/15								
3900007	3/15								
3900012	3/16								
3940004	2/28								
3940009	3/13								
3940010	3/13								
3940014	2/29								
3940019	2/30								
3940020	3/14								

Artikel-Nr. <i>Article-no.</i>	Seite <i>Page</i>	Artikel-Nr. <i>Article-no.</i>	Seite <i>Page</i>	Artikel-Nr. <i>Article-no.</i>	Seite <i>Page</i>	Artikel-Nr. <i>Article-no.</i>	Seite <i>Page</i>	Artikel-Nr. <i>Article-no.</i>	Seite <i>Page</i>
J0013	4/14	4910021	4/12						
198059	4/28	4910022	4/13						
198133	4/35	4910023	4/13						
4000207	4/30	4910024	4/13						
4010003	4/11	4910032	4/13						
4010015	4/11	4910084	4/14						
4010016	4/11	4910100	4/14						
4010017	4/12	4920002	4/15						
4010018	4/12	4920003	4/15						
4010443	4/12	4920012	4/15						
4020006	4/15	4920013	4/16						
4020049	4/17	4920094	4/16						
4020639	4/15	4930019	4/18						
4030035	4/17	4930025	4/18						
4030302	4/18	4930028	4/19						
4030305	4/18	4930029	4/19						
4030334	4/18	4930033	4/19						
4030382	4/17	4930035	4/19						
4030383	4/17	4930091	4/19						
4040085	4/22	4940077	4/20						
4040086	4/20	4940088	4/21						
4040456	4/20	4940114	4/21						
4040610	4/19	4940116	4/21						
4040678	4/20	4940117	4/21						
4040700	4/20	4940166	4/21						
4050150	4/24	4940170	4/22						
4050153	4/24	4940187	4/22						
4060377	4/26	4940535	4/23						
4060386	4/26	4950008	4/24						
4060388	4/26	4950092	4/24						
4070000	4/28	4950095	4/24						
4070002	4/28	4950096	4/24						
4070008	4/28	4950099	4/25						
4070010	4/28	4950239	4/25						
4070011	4/28	4950264	4/25						
4070012	4/29	4950266	4/25						
4070025	4/34	4960002	4/26						
4070026	4/34	4960004	4/27						
4070030	4/20	4960009	4/27						
4070046	4/34	4960026	4/27						
4070047	4/34	4970706	4/34						
4070056	4/33	4970722	4/29						
4070115	4/33	4980064	4/31						
4070163	4/33	4980065	4/31						
4070164	4/33	4990003	4/14						
4070525	4/34	4990005	4/31						
4080318	4/30	4990009	4/14						
4080350	4/30	4990012	4/31						
4080367	4/30	4990013	4/31						
4080452	4/30	4990018	4/32						
4080454	4/30	8030015	4/22						
4900073	4/31								
4910004	4/11								

Artikel-Nr. <i>Article-no.</i>	Seite <i>Page</i>	Artikel-Nr. <i>Article-no.</i>	Seite <i>Page</i>	Artikel-Nr. <i>Article-no.</i>	Seite <i>Page</i>	Artikel-Nr. <i>Article-no.</i>	Seite <i>Page</i>	Artikel-Nr. <i>Article-no.</i>	Seite <i>Page</i>
6000005	5/9	6950060	5/13						
6000006	5/14	6950061	5/3						
6000010	5/16	6950169	5/5						
6000011	5/16	6950170	5/12						
6000012	5/16	6950300	5/15						
6050326	5/8								
6051032	5/15								
6051033	5/15								
6081398	5/14								
6920071	5/12								
6920241	5/12								
6950012	5/3								
6950013	5/3								
6950014	5/3								
6950015	5/4								
6950016	5/4								
6950017	5/4								
6950018	5/4								
6950019	5/5								
6950020	5/5								
6950021	5/6								
6950022	5/6								
6950023	5/6								
6950024	5/6								
6950025	5/7								
6950026	5/7								
6950027	5/7								
6950028	5/7								
6950029	5/8								
6950030	5/8								
6950031	5/8								
6950032	5/8								
6950033	5/9								
6950034	5/9								
6950035	5/9								
6950036	5/9								
6950038	5/10								
6950039	5/10								
6950040	5/10								
6950041	5/11								
6950042	5/10								
6950043	5/11								
6950044	5/11								
6950045	5/11								
6950047	5/12								
6950049	5/12								
6950051	5/11								
6950054	5/13								
6950055	5/13								
6950056	5/13								
6950057	5/13								
6950058	5/14								
6950059	5/15								

Artikel-Nr. <i>Article-no.</i>	Seite <i>Page</i>	Artikel-Nr. <i>Article-no.</i>	Seite <i>Page</i>	Artikel-Nr. <i>Article-no.</i>	Seite <i>Page</i>	Artikel-Nr. <i>Article-no.</i>	Seite <i>Page</i>	Artikel-Nr. <i>Article-no.</i>	Seite <i>Page</i>
5010598	6/4	5060107	6/19	5970006	6/25				
5010615	6/4	5060400	6/19						
5010622	6/4	5060401	6/19						
5010625	6/4	5060402	6/19						
5010630	6/5	5060419	6/20						
5010641	6/4	5060422	6/16						
5030075	6/10	5060424	6/16						
5030100	6/10	5060425	6/16						
5030101	6/10	5060426	6/16						
5030102	6/11	5070000	6/21						
5030103	6/11	5070001	6/21						
5040000	6/6	5070002	6/21						
5040003	6/6	5070003	6/22						
5040004	6/6	5070004	6/22						
5040005	6/6	5070012	6/23						
5040101	6/8	5070015	6/23						
5040150	6/9	5070016	6/23						
5040151	6/9	5070024	6/23						
5040152	6/9	5070025	6/23						
5040166	6/9	5070043	6/24						
5040421	6/6	5070044	6/24						
5060001	6/12	5070224	6/21						
5060002	6/12	5070225	6/22						
5060003	6/12	5070226	6/22						
5060004	6/12	5070227	6/22						
5060012	6/12	5070229	6/24						
5060013	6/12	5370004	6/24						
5060014	6/13	5370005	6/24						
5060015	6/13	5910041	6/4						
5060016	6/13	5910051	6/5						
5060017	6/13	5910057	6/5						
5060024	6/14	5910062	6/5						
5060025	6/14	5910073	6/5						
5060031	6/14	5930001	6/10						
5060032	6/14	5930013	6/10						
5060051	6/15	5930014	6/10						
5060053	6/15	5940001	6/7						
5060055	6/15	5940014	6/7						
5060060	6/15	5940015	6/7						
5060061	6/15	5940028	6/7						
5060070	6/17	5940030	6/7						
5060071	6/17	5940031	6/7						
5060073	6/17	5940042	6/8						
5060075	6/17	5940101	6/8						
5060076	6/17	5940113	6/8						
5060077	6/17	5940115	6/8						
5060080	6/18	5950023	6/3						
5060089	6/18	5960007	6/14						
5060101	6/18	5960012	6/13						
5060102	6/18	5960013	6/13						
5060103	6/18	5970002	6/21						
5060104	6/18	5970003	6/25						
5060105	6/19	5970004	6/25						

1. Werkstoff, Maßtoleranzen

WICONA-Profile werden im Strangpressverfahren aus der Aluminium-Legierung EN AW-6060 T66 (AlMgSi0,5 F22) warm ausgehärtet nach DIN EN 573-3, DIN EN 573-4 und DIN EN 755-2 hergestellt. Diese Legierung ist sehr korrosionsbeständig, gut anodisierbar und von hoher Festigkeit. Die Technischen Lieferbedingungen und Maßtoleranzen sind in DIN EN 12020-1 und DIN EN 12020-2 festgelegt.

2. Auswahl der Profile, Zubehörteile und Beschläge

Die Auswahl von Profilen, Zubehör und Beschlägen erfolgt eigenverantwortlich durch den Verarbeiter, abhängig von den baulichen Gegebenheiten, den statischen Erfordernissen, den architektonischen Vorstellungen und den Kundenwünschen, sowie unter Beachtung unserer Verarbeitungsrichtlinien. Bei der Festlegung von Elementgrößen müssen zur Aufnahme von Wärmedehnungen und Bauwerksbewegungen Fugen in der Rahmenkonstruktion und gegebenenfalls auch im Bauanschluss vorgesehen werden. Die in unseren Unterlagen dargestellten Bauanschlüsse müssen vom Verarbeiter den jeweiligen baulichen Bedingungen angepasst werden.

Zu beachten sind unsere Angaben über zulässige Flügelgrößen, -gewichte und -formate sowie Normen, Hinweise und Vorschriften von Fachverbänden und behördliche Verordnungen.

3. Bestellung

Alle Artikel der Profilprogramme können bei den eingerichteten Verkaufsbüros von WICONA und bei unseren anderen Vertriebspartnern bestellt werden. Pressblanke Profile, Zubehörteile und Beschläge werden aus Lagervorrat geliefert. Zwischenverkauf bleibt vorbehalten.

Bis auf wenige Ausnahmen sind die Profile dieser Liste objektbezogen nach Terminvereinbarung auch oberflächenveredelt lieferbar. Die Verkaufsbedingungen sind der WICONA-Preisliste zu entnehmen.

Lieferlängen sind in den Datenblöcken und der Preisliste der Profile angegeben. Die dort angegebenen Außenabwicklungen enthalten bei Verbundprofilen die gesamte sichtbare Abwicklung ohne Dämmleisten.

4. Transport

WICONA-Profile werden werkseitig mit äußerster Sorgfalt behandelt um Korrosion und mechanische Beschädigungen beim Transport und in den WICONA-Lagern auszuschließen. Diesem Zweck dient die Portionsverpackung in PE-Folie, gegebenenfalls unter Anwendung von Schutzöl.

Der Transport erfolgt durch WICONA oder durch Vertragsspediteure ausschließlich auf Fahrzeugen mit gedeckter Ladefläche und unter Beachtung unserer Verpackungs-, Verlade- und Transportvorschriften. Damit ist die größtmögliche Sicherheit gegeben, dass WICONA-Profile unbeschädigt beim Empfänger ankommen.

Mit der Übergabe der Ware an einen Spediteur oder Frachtführer, spätestens jedoch mit verlassen des Lagers oder des Lieferwerks, geht die Gefahr auf den Käufer über. Wird beim Eingang der Ware festgestellt, dass Verpackungen nass oder beschädigt sind, so muss dies beim Fahrer reklamiert werden; die Beanstandung muss mit Gegenzeichnung des Fahrers auf dem Lieferschein vermerkt werden. Zusätzlich muss dies dem Lieferer innerhalb von 7 Tagen schriftlich mitgeteilt werden. Nicht transportbedingte Sachmängel müssen, soweit durch zumutbare Untersuchungen feststellbar, unverzüglich, spätestens 7 Tage nach Warenanlieferung schriftlich mitgeteilt werden. Bei der ersten Untersuchung nicht erkennbare Mängel sind unverzüglich nach Feststellung unter sofortiger Einstellung laufender Be- oder Verarbeitung schriftlich anzuzeigen. Schadensmeldungen, die diese Fristen überschreiten, können wir nicht anerkennen. Zum Abladen am besten geeignet ist ein Kran mit Traverse und zwei Gurten mit mindestens 80 mm Breite. Wird mit Stapler abgeladen und transportiert, so nur mit breiten, auf großen Abstand eingestellten Gabelzinken. Die Auslieferungsfahrer sind angewiesen, unsachgemäßes Abladen zu melden.



1. Material, Dimensional tolerances

WICONA profiles are manufactured in extrusion process from aluminium alloy EN AW-6060 T66 (AlMgSi0,5 F22) and age hardened according to DIN EN 573-3, DIN EN 573-4 and DIN EN 755-2. This alloy is highly corrosion-resistant, good for anodic treatment and is of high strength. The technical delivery terms and dimensional tolerances are predetermined in DIN EN 12020-1 and DIN EN 12020-2.

2. Selection of profiles, accessories and fittings

Selection of profiles, accessories and fittings is the fabricator's own responsibility, dependent on the structural conditions, the statical requirements, the architectural conceptions and customer wishes whilst observing the guidelines of our Workshop Manual. Gaps in the frame construction and if necessary, also in the junctions to structure should be provided with regard to thermal expansions and structural movements when determining unit sizes. The junctions to structure, represented in our documents, must be adapted to the respective structural conditions by the fabricator.

Please follow our specifications concerning admissible sash/leaf sizes, weights and formats as well as standards, hints and instructions of professional associations and regulations of public authorities.

3. Ordering

All articles of our Profile Programme can be ordered from the established WICONA sales offices and other sales partners. Extruded profiles, accessories and fittings are delivered ex stock and are subject to prior (intermediate) sale.

Apart from few exceptions, the profiles included in this Programme List are also deliverable project based and surface treated according to the stipulated delivery time. Please refer to the current WICONA price list for sales conditions.

The delivery lengths are indicated in the data blocks and price list of profiles. The outer perimeter listed therein includes the total visible perimeter of composite profiles without the perimeter of thermal break strips.

4. Transport

WICONA profiles are treated with utmost care in the factory in order to prevent corrosion and avoid mechanical damages during transport and at the WICONA stocks. For this purpose, the profiles are bundled in portion packs in polyethylene foil and, when necessary, with application of a protective oil film.

The transport takes place through WICONA or contract forwarding agents, exclusively on vehicles with covered loading area considering our packaging, loading and transport prescriptions. This provides maximum safety for WICONA profiles to reach the addressee undamaged.

With the transfer of goods to a forwarding agent or freight carrier, the responsibility goes over to the purchaser, at the latest however on leaving the warehouse or supplying factory. If on receipt, the goods are found to be damaged or the packages are wet, complaint should be noted in the delivery receipt with countersignature of the driver. In addition, written notice should be sent to the supplier within 7 days. Quality defects other than transport damages, as far as identifiable through reasonable inspections, should be reported through written notice immediately, at the latest 7 days after delivery of goods. Not identifiable defects at the initial stage of inspection should be reported immediately by written notification after the identification while stopping the running processing. We cannot accept damage reports received after this time limit. A crane with traverse and two belts with minimum 80 mm width is best suited for unloading. If a fork lift truck is used for unloading and transport, then only with wide and widely spaced fork prongs. The truck drivers have instructions to report improper unloading procedures.

5. Lagerung beim Verarbeiter

Jede Einwirkung von Feuchtigkeit, auch durch Handschweiß oder durch Tauwasserbildung, kann bei pressblanken Aluminiumprofilen Korrosion auslösen. Auch eloxierte Oberflächen können durch alkalische Stoffe, z. B. Zement, Kalk, Mörtel oder durch Flugrost, Stahlspäne und dergleichen angegriffen werden. Wichtig ist daher eine trockene Lagerung in einem gedeckten Raum und die Vermeidung starker Temperaturschwankungen im Lager. Ein optimaler Schutz pressblanker Aluminiumprofile wird dadurch erreicht, dass sie erst unmittelbar vor der Weiterverarbeitung aus der werkseitigen PE-Folienverpackung entnommen werden. Eine starke Aufheizung der verpackten Profile durch direkte Sonneneinstrahlung muss vermieden werden.

Auflageflächen und seitliche Anlagen von Lagergestellen müssen aus nicht aggressivem Holz oder Kunststoff bestehen. Beim Entnehmen werden die Profile nur herausgehoben, keinesfalls aus dem Stapel herausgezogen. Bei jedem Handling von pressblanken Profilen sollten trockene, saubere Handschuhe getragen werden. Oberflächenbehandelte Profile sind gegen Korrosionsangriff durch Bewitterung und normale atmosphärische Einflüsse bestens und dauerhaft geschützt. Stoß-, Druck- und Biegebeanspruchungen können zu Beschädigungen von Eloxal und Beschichtung führen. Solche Schäden können in der Regel durch Nachbehandlung nicht beseitigt werden.

6. Verarbeitung

Genaue, vollständige und verbindliche Angaben zur Profilbearbeitung, Profilverbindung und zum Einbau von Beschlägen und Zubehör sind in unseren Verarbeitungsunterlagen enthalten.

Zur spanenden Bearbeitung von Aluminium sind Werkzeuge mit spezieller Schneidengeometrie über den Fachhandel lieferbar. Für saubere Schnitte ist das regelmäßige Nachschärfen der Werkzeuge und die Verwendung geeigneter Kühlschmiermittel wichtig. Für die wirtschaftliche Verarbeitung aller WICONA-Systeme bieten wir ein umfassendes Sortiment von Bearbeitungs- und Einbauschablonen, Montagehilfsmitteln, systembezogenen Spezialwerkzeugen, Stanzwerkzeugen und kompletten Stanzeinheiten an. Auch bei der Verarbeitung ist größte Sorgfalt geboten, um Schäden auf veredelten Oberflächen zu vermeiden. Eckverbindung mit Hülse: bei erhöhten optischen Anforderungen, oder sehr empfindlichen Sichtflächen, welche die in den Merkblättern VFF* Al.02 und VFF Al.03 dargestellten Mindestanforderungen unter Punkt "Fertigungsbedingte mechanische Beschädigungen" überschreiten, sollte an Stelle der vorgegebenen Hülse mit Bund (4070000), die Hülse ohne Bund (4070008) verwendet werden. Damit lassen sich bei Verbolzungsstellen, die sehr dicht an der Sichtfläche liegen, Abzeichnungen vermeiden.

Bei der Verwendung der Hülse ohne Bund (4070008) ist bei der Verarbeitung auf eine flächenbündige Setztiefe zu achten.

Spannbacken und Auflagen von Arbeitstischen sollten aus Holz oder Kunststoff bestehen und regelmäßig von darauf haftenden Spänen gereinigt werden; Stahlhämmer dürfen zur Profilbearbeitung nicht verwendet werden. Die meisten WICONA-Beschläge sind werkseitig gefettet; hingegen müssen Treibstangenkanäle, Drehkippscheren und Riegelschieber, Verriegelungsgarnituren und die zugänglichen beweglichen Teile von Fenstergetrieben, Handhebeln und Oberlichtöffnern beim Einbau leicht gefettet werden. Für die Reinigung fertiger Elemente liefert WICONA geeignete Mittel, die bei vorschriftsmäßiger Anwendung mit eloxierten bzw. beschichteten Oberflächen verträglich sind. Wir weisen besonders darauf hin, dass manche im Handel erhältlichen Produkte farbbeschichtete Oberflächen angreifen können.

5. Storage at the fabricator

Any influence of moisture, also through hand perspiration or formation of condensation water, can cause corrosion of extruded aluminium profiles. Even anodized surfaces can be attacked by alkaline substances, e.g. cement, lime, mortar or volatile rust, steel chips or similar. Hence, it is important to store profiles in a dry and covered room and avoid higher temperature fluctuations in the warehouse. Optimum protection of extruded aluminium profiles is achieved by unpacking from the factory packed Polyethylene foil just before further machining.

Strong heating through direct solar radiation of packaged profiles should be avoided.

The bearing surfaces and lateral supports of storage racks must be made of non-aggressive wood or plastic.

Only remove the profiles from the storage rack by lifting, never by pulling them out of stacks. Always wear dry and clean gloves whenever handling millfinished extruded profiles.

Surface treated profiles are well and durably protected against corrosive attacks through weathering and normal atmospheric influences. Impact, compressive and bending stress can lead to damages of anodized and coated surfaces of profiles.

Usually, such damages cannot be eliminated through after-treatment.

6. Processing

Our Workshop Manual provides precise, complete and binding specifications for processing and connecting profiles as well as for the assembly of fittings and accessories.

Tools with special cutting edge geometry for machining aluminium can be obtained from specialized dealers. Regular re-sharpening of tools and application of appropriate cooling lubricants is important for obtaining clean cuts. We offer a comprehensive range of processing and assembly templates, assembly auxiliary means, system specific special tools, punching tools and complete punching units for most efficient and economical processing of all WICONA systems.

The machining should also be done with outmost care to avoid damages on surface treated aluminium profiles. Corner junction with bush: for increased optical requirements or for very delicate visible surfaces which exceed the minimum requirements set out by the VFF* Al.02 and VFF Al.03 leaflets under point "Manufacturing-related mechanical damages", the bush without collar (4070008) should be used instead of the specified bush with collar (4070000). That way, for bolting areas which are very close to the visible surface of the profile, slight surface deformations can be avoided.

When using the bush without collar (4070008), it is important to pay attention during manufacture that the seating depth is flush with the surrounding profile area.

Clamping jaws and supports of work benches should be made of wood or plastic and must be cleaned regularly from chips adhering to them. Steel hammers should not be used for processing profiles. Most of WICONA fittings are delivered greased ex factory, however drive rod channels, turn/ tilt retainer arms, lock slide rod, locking sets and the accessible movable parts of window gears, hand levers and fanlight openers must be slightly greased while assembling.

WICONA provides appropriate cleaning agents for fabricated units which are compatible with the anodized and coated surfaces when used according to prescriptions. Particularly, we would like to point out that some products offered on the market could attack colour coated profile surfaces.



7. Oberflächenbeschaffenheit und -behandlung

Auf den Sichtflächen der pressblanken Aluminiumprofile sind nach EN 12020-1 leichte Riefen und andere leichte Aufrauungen, z.B. Scheuerstellen, zulässig. Inwieweit diese bei der nachfolgenden Oberflächenbehandlung beseitigt werden, hängt von der Art der Behandlung ab.

Die **Eloxalbehandlung** ist nach EN 12373 und den Bestimmungen der GÜTEGEMEINSCHAFT ANODISIERTES ALUMINIUM E.V. (GAA), bzw. den Bestimmungen für das Gütezeichen für anodisch erzeugte Oxidschichten auf Aluminium Halbzeug (Ausgabe Sept. 2004) der Qualanod-Zürich, CH-8027 Zürich oder vergleichbaren lokalen Vorschriften und Bestimmungen auszuführen.

Bei einer Vorbehandlung ohne wesentlichen Oberflächenabtrag nach E0 bleibt die durch Herstellung und Bearbeitung bedingte Oberflächenbeschaffenheit erhalten. Auch bei einer chemischen Vorbehandlung in Spezialbeizen nach E6 werden leichte Riefen und Aufrauungen nicht beseitigt, sondern höchstens ausgeglichen und bei beiden Vorbehandlungen können Korrosionserscheinungen, die in pressblankem Zustand nicht oder kaum wahrgenommen wurden, sichtbar werden. Gefügeunregelmäßigkeiten und Strangpressnähte können insbesondere bei E6 hervorgehoben werden. Bei höheren Ansprüchen an das dekorative Aussehen muss eine mechanische Vorbehandlung nach einem der in EN 12373 aufgeführten Verfahren E1...E5 vorgenommen werden.



Zulässige Abweichungen in Aussehen und Farbe müssen zwischen den Vertragspartnern vereinbart werden, am besten mit Hilfe von Grenzmustern. EN 12373 enthält Kriterien für die Beurteilung des dekorativen Oberflächenaussehens.

Die **Beschichtung** von Aluminiumprofilen ist nach den Güte- und Prüfbestimmungen der GSB INTERNATIONAL Gütegemeinschaft bzw. den Vorschriften zur Erlangung eines Gütezeichens für Beschichtungen auf Aluminium durch Nass- und Pulverlackierung bei Architekturanwendungen (Ausgabe 2003) der Qualicoat Gütegemeinschaft, Zürich, oder vergleichbaren lokalen Vorschriften und Bestimmungen auszuführen. Auch diese Richtlinien enthalten Angaben zur Beurteilung der Oberflächen. Bei Pulverlacken beträgt die Schichtdicke auf Sichtflächen bei Außenanwendung 50...120 µm.

Zu vermeiden sind örtliche Lackanhäufungen bei Einschub-, Schnapp-, Klips- oder Drehverbindungen oder in den Aufnahmen von Dichtungen. Derartige Profilpassungen sind von uns auf die normalen Wanddickenveränderungen durch Oberflächenbehandlung ausgelegt; übermäßiger Lackauftrag kann Funktion und Verbindungsmöglichkeit beeinträchtigen. Schieberstangen sollten möglichst nur eloxiert werden; eine Beschichtung, falls unumgänglich, sollte auf eine Schichtdicke von 30 µm beschränkt werden. Der Verarbeiter muss dafür Sorge tragen, dass die in seinem Auftrag arbeitende Eloxal- bzw. Beschichtungsanstalt angelieferte pressblanken Profile mit erkennbaren Oberflächenschäden (auch Korrosion) oder mit starken Verwindungen nicht bearbeitet, wenn absehbar ist, dass diese Profile nach der Oberflächenbehandlung verworfen werden. WICONA übernimmt keine Kosten, die aus der Nichtbeachtung dieser Auflage entstehen.

8. Verhütung von Korrosions- und Oberflächenschäden am Bau

Aluminium kann beim Zusammenbau mit anderen metallischen Werkstoffen, ausgenommen rostfreier Stahl der Werkstoffgruppe 1.4301 (A2) und 1.4401 (A4) nach EN 10088-1, durch Bildung von Kontaktelementen angegriffen werden. Dies gilt besonders für die Verbindung mit Kupfer und Kupferlegierungen. Abhilfe ist möglich durch Vermeiden von direktem metallischem Kontakt, z.B. mittels geeigneten Schutzanstrichen oder Kunststoff-Zwischenlagen.

Ein optimaler Schutz von Aluminiumbauteilen während der Bauarbeiten wird durch Verwendung von Einputz-Zargen erreicht, in welche die Bauteile erst nach Abschluss der Maurer- und Putzarbeiten eingesetzt werden. Bei Anwendung anderer Schutzverfahren (Abzieh- oder Klarlacke, selbstklebende Kunststoff-Folien) ist ausschließlich der Anwender dafür verantwortlich, dass die verwendeten Produkte uneingeschränkt mit eloxierten oder farb-

7. Surface finish and treatment

Slight score marks and other slight roughness such as chafe marks on visible surfaces of extruded aluminium profiles are admissible according to EN 12020-1. The extent of removal of these defects depends on the kind of subsequent surface treatment.

The anodic treatment has to be performed according to the European Standard EN 12373 and the regulations of GÜTEGEMEINSCHAFT ANODISIERTES ALUMINIUM E. V. (GAA) (Association for quality mark of anodic oxide layer on semi finished aluminium, September 2004 Edition) of Qualanod-Zürich, CH-8027 Zürich, Switzerland or comparable local rules and regulations.

In case of a pretreatment without significant surface abrasion, the consistency of profile surface at the stage of extrusion and processing remains preserved even after the anodic treatment E0. Even after a chemical pretreatment of special pickling and anodic treatment of E6, the slight score marks and roughness are not eliminated but at the most counterbalanced and in both cases of pretreatment, the signs of corrosion, hardly perceived in extruded condition, may become visible. Structural irregularities and extrusion seams can be visible especially after the anodic treatment of E6. For higher requirements on decorative appearance, a mechanical pretreatment should be carried out according to one of the procedures of E1 up to E5 described in EN 12373. Admissible deviations in

appearance and colour must be stipulated between the contracting partners, preferably with the help of limiting samples. The European Standard EN 12373 includes criteria for evaluation of decorative appearance of the surface.

The coating of aluminium profiles has to be carried out according to quality and test regulations of GSB INTERNATIONAL (Quality association for coating of construction parts) and according to regulations for attainment of quality mark for wet and powder coatings on aluminium in architectural applications (Edition of 2003) of Qualicoat Gütegemeinschaft, Zürich or comparable local rules and regulations. Also these guidelines include specifications for evaluation of surfaces. The powder coat thickness for outer application is 50 up to 120 µm.

Local lacquer accumulation in areas of sliding, snapping, turning connections and in retaining grooves of gaskets should be avoided. Such profile fitting is designed for normal changes of profile wall thickness through surface treatment; excessive coating can impair the function and connecting possibility. As far as possible, slide rods should only be anodized. If a coating is unavoidable, then the coating thickness should be limited up to 30 µm. The processor should ensure that the anodizing or coating factory working for him do not process extruded profiles with visible surface damages (also corrosion) if it is predictable that these profiles cannot be used for fabrication after the surface treatment.

WICONA cannot be held responsible for resulting damages and costs.

8. Prevention of corrosion and surface damages of profiles at site

Aluminium can be attacked due to assembly with other metallic materials except stainless steel of material group 1.4301 (A2) and 1.4401 (A4) corresponding to EN 10088-1. Especially, this applies to connection with copper and copper alloys. Direct metallic contact can be avoided with the help of e.g. plastic inter layers or protective coating.

Optimum protection of aluminium construction parts is achieved during the construction works by using plastering frames, in which the structural components are mounted after the completion of masonry and plastering works. For application of other protection procedures (strip lacquer or clear lacquer, self-adhesive plastic foils) the user is solely responsible with regard to the absolute compatibility of used products with the anodized or colour coated aluminium structural parts. In order to obviate rights of recourse for damages caused by

beschichteten Aluminiumbauteilen verträglich sind. Um Regressansprüchen für von Dritten verursachte Schäden vorzubeugen, empfiehlt sich bei größeren Objekten die Zwischenabnahme von Bauabschnitten sofort nach deren Fertigstellung. Die üblichen Hinweisschilder, mit denen andere Gewerke zur sorgfältigen Behandlung von Aluminium-Bauteilen aufgefordert werden, reichen nicht aus, um den Verarbeiter von möglichen Schadenersatzansprüchen zu entlasten. Korrosionsschutz für Stahlteile, Anschlüsse und Verstärkungen nach DIN 55928.

Bei der Oberflächenbehandlung von WICONA-Verbundprofilen müssen die Hinweise im nachfolgenden Anhang beachtet werden.

9. Verglasung, Fugenabdichtung

Glasmaße werden mit den Formeln unserer Stücklisten-Beispiele bzw. mit den Angaben unserer sonstigen Planunterlagen errechnet. Die Verglasung erfolgt entsprechend DIN 18361, den Verklotungsvorschriften des Glaserhandwerks und den Richtlinien der Isolierglas-Hersteller. Besonders zu beachten sind die Vorschriften hinsichtlich des Dampfdruckausgleichs (zugleich Entwässerung) aus freien Falzräumen. Alle WICONA-Systeme sind für die Verglasung zwischen Elastomer-Dichtprofilen eingerichtet. Diese bestehen bis auf wenige Ausnahmen aus EPDM nach DIN 7863; zur Erleichterung des Einbaus sind sie mit Gleitpolymer beschichtet. Die Zuordnung von Füllungsdicke (einschließlich Dickentoleranz), Glasleiste und Dichtungsprofil ist in den Auswahltabellen dieser Lagerliste dargestellt. Dichtungsprofile dürfen nicht unter Zug eingebaut werden, sondern sind bei rund umlaufenden Dichtungen in den Ecken zu stauchen und oben zu stoßen. Hilfswerkzeuge hierfür sind lieferbar. Vulkanisierte Dichtungsrahmen werden von den Rahmenecken ausgehend zur Feldmitte hin verlegt.

Andere Verglasungssysteme mit ein- oder beidseitiger Anwendung von Dichtstoffen setzen die Verwendung spezieller Glasleisten voraus.

Bei Füllungen aus Acrylglas (PMMA) und Polycarbonat (PC) kann im Kontakt mit unseren EPDM-Dichtungen die Gefahr von Spannungsrissen in diesen Platten nicht ausgeschlossen werden. Das Risiko der Unverträglichkeit liegt außerhalb unserer Kontrolle und ist vom Verarbeiter mit den Herstellern solcher Füllungen abzuklären.

Für die Abdichtung von Bauanschluss- und Konstruktionsfugen bieten wir in unserem Programm geeignete Dichtstoffe, bei denen Adhäsion und Verträglichkeit auch mit farbbeschichteten Aluminiumflächen gesichert sind. Die Verarbeitungsmerkblätter und die Sicherheitsdatenblätter dieser Stoffe sind zu beachten. Bei anderweitig beschafften Dichtstoffen obliegt dem Verarbeiter die Verantwortung für deren Auswahl.

10. Reinigung von WICONA-Bauteilen

Außenwandelemente sind neben der Beanspruchung durch Sonne und Regen aggressiven Luftbestandteilen ausgesetzt und unterliegen damit unvermeidlich einer Verschmutzung. Diese beeinträchtigt nicht nur das Aussehen der Fassade, sondern stellt durch die ständige Einwirkung der Schmutzablagerungen auch ein Korrosionsrisiko dar. Die Bauteile müssen daher in Intervallen, die je nach Standort unterschiedlich sind, gereinigt werden.

Ausführliche Hinweise zur Reinigung von Aluminiumbauteilen sind in unserem WICONA-Bedienungs- und Wartungshandbuch, sowie im technischen Merkblatt:

A05 Reinigen von Aluminium im Bauwesen bei der Aluminium-Zentrale e. V., Am Bonnehof 5, 40474 Düsseldorf enthalten; diese stellt auch eine Liste geeigneter neutral reagierender Reinigungsmittel zur Verfügung. Speziell zur Reinigung von Fassadenobjekten verweisen wir auf die GÜTEGEMEINSCHAFT FÜR DIE REINIGUNG VON METALL-FASSADEN E.V. (GRM), deren Mitglieder eine RAL gütegesicherte Reinigung von Fassaden anbieten.

third party, it is recommended to have intermediate inspection of construction stages of major projects immediately after completion. The usual information signs for careful treatment of aluminium construction parts are not sufficient to relieve the processor from possible indemnity claims.



Corrosion protection for steel parts, junctions and reinforcements according to DIN 55928 (German Industrial Standard).

Indications in the following appendix should be observed for surface treatment of WICONA composite profiles.

9. Glazing, Joint sealing

Glass dimensions are calculated with the help of formulas of our material schedule examples and specifications in other planning documents. Glazing follows according to DIN 18361 and the shimming regulations of glazier trade and guidelines of insulation glass manufacturers. Pay attention especially to the regulations with regard to air pressure equalization (drainage at the same time) of open rebate areas. All WICONA systems are designed for glazing between Elastomer gasket profiles. Apart from few exceptions, these gaskets are made of EPDM according to DIN 7863 (German Industrial Standard). They are coated with Polymer (glide-polymerized) to facilitate assembly. The assignment of infill thickness (including thickness tolerance), glazing bead and gasket profile is shown in the selection tables of this profile programme catalogue. The gasket profiles should not be stretched during installation, but continuous gaskets must be compressed in the corners and butt-joined at the top. Auxiliary tools for this purpose are available. Vulcanized gasket frames are mounted starting from the frame corners to field centre. Other glazing systems with single or both sided use of sealants imply the use of specifically designed glazing beads.

The danger of tension cracks caused by contact with our EPDM gaskets while using infill plates made of acrylic glass (PMMP=Polymethyl methacrylate) and Polycarbonate (PC) cannot be ruled out.

The risk of incompatibility lies beyond our control and the fabricator should clarify this with manufacturers of such infills.

We offer in our programme suitable sealants for sealing junctions to structure and construction joints, ensuring adhesion and compatibility also with colour coated aluminium surfaces. The processing and security data leaflets of these sealants should be considered. The fabricator (processor) bears the responsibility for choice and procurement of sealants elsewhere.



10. Cleaning WICONA construction units

Besides stress from sun radiation and rain, the outer wall units are exposed to aggressive air constituents and thus soiling is unavoidable. This impairs not only the appearance of façade, but also constitutes the risk of corrosion through constant effect of dirt accumulations. Hence, the components must be cleaned at regular intervals, the length of which being dependent on the different locations and respective environmental loads.

Detailed indications for cleaning aluminium structural components are included in our WICONA operating and maintenance handbook and the technical leaflet:

A05 Cleaning of Aluminium in civil engineering available at the Aluminium-Zentrale e.V., Am Bonnehof 5, 40474 Düsseldorf. They also provide a list of appropriate and neutral cleaning agents. Especially for cleaning of façade projects, we refer you to the GÜTEGEMEINSCHAFT FÜR DIE REINIGUNG VON METALL-FASSADEN E.V. (GRM), whose members offer a RAL quality assured cleaning procedure of façades.

Wir beschränken uns nachfolgend auf einige wesentliche Hinweise:

- Leichte Verschmutzungen mit Wasser unter Zusatz eines neutralen Reinigungsmittels (keine Seifenlauge!) mit Schwamm und Tuch entfernen. Danach mit klarem Wasser gründlich spülen.
- Stärkere Verschmutzungen erfordern schwach abrasiv wirkende Reiniger, diese dürfen jedoch nicht auf Glas angewandt werden.
- Bei beschichteten Oberflächen sollte zuvor durch eine Probeanwendung auf einer verdeckt liegenden Fläche sichergestellt werden, dass der Lack weder mechanisch noch chemisch angegriffen wird.
- Auszuschließen sind in jedem Fall Reinigungsmittel mit pH-Werten unter 5 oder über 8 sowie scheuernd oder schmirgelnd wirkende Mittel ebenso Stahlwolle oder Drahtbürsten.

11. Wartung von WICONA-Bauteilen

Sofern keine Funktionsstörungen oder durch unsachgemäßen Umgang verursachte Schäden vorliegen, kann die Wartung durch den privaten Hausbesitzer sich darauf beschränken, zugängliche gleitende Beschlagteile in größeren Zeitabständen leicht zu ölen oder zu fetten. Wartungsarbeiten bei größeren Objekten und bei öffentlichen Gebäuden gehören in die Hand des Fachmanns, zumal wenn sie mit weitergehenden Erhaltungsmaßnahmen verbunden sind.

Hier kann der Verarbeiter durch den Abschluss eines Wartungsvertrags mit der Bauherrschaft sicherstellen, dass die Qualität seiner Arbeit über einen langen Nutzungszeitraum zur Zufriedenheit seines Kunden erhalten bleibt.

12. Funktionsfähigkeit

WICONA-Fenster erfüllen die Anforderungen hinsichtlich der Fugendurchlässigkeit, (EN 12207), Schlagregendichtheit (EN 12208), Widerstandsfähigkeit bei Windlast (EN 12210) und den Richtlinien der Gütegemeinschaft Aluminiumfenster. Systemprüfberichte stehen zur Verfügung, ebenso Prüfzeugnisse über Sonderprüfungen bezüglich Schallschutz, Angriffshemmung und Rauchdichtheit bei Türen. Die Dichtungs- und Entwässerungssysteme der dargestellten Serien funktionieren in der Regel nur bei lotrechtem Einbau. Im Zweifelsfall bitten wir um Rückfrage.

WICONA-Fenster und -Fenstertüren entsprechen bei Kombination mit geeigneten Isoliergläsern, insbesondere Wärmeschutzgläsern den Anforderungen der Energieeinsparverordnung von 2009.

Über die Einstufung unserer wärmedämmten WICONA-Systeme nach EN ISO 10077-1(2) geben entsprechende Unterlagen Auskunft.

Mit dieser Einstufung und den von den Glasherstellern angegebenen U_g -Werten lassen sich die U_w -Rechenwerte für verglaste Fenster und Fenstertüren ermitteln.



13. Technische Service-Leistungen

Unsere Planungs- und Zeichnungsunterlagen, Verarbeitungsrichtlinien und Beschlagseinbaupläne erleichtern Ihnen die Verarbeitung unserer Systeme. Darüber hinaus stehen Ihnen die Beratungsdienste von WICONA und unseren Vertriebspartnern zur Verfügung. Unterlagen und Beratungen entsprechen unserem besten Wissen. Eine Gewähr für Fehlerfreiheit kann jedoch nicht übernommen werden, es sei denn, die Fehler beruhen auf Vorsatz oder grober Fahrlässigkeit unsererseits.

Unsere Verarbeiter bieten wir Schulungen vor Ort oder Seminare in unserem Technologie-Zentrum mit mehrtägiger intensiver Unterweisung in Theorie und Praxis des Metallbaus. Unser PC-Softwarepaket WICTOP/WICPLOT eröffnet die vielseitigen Möglichkeiten moderner Datenverarbeitung bei Angebotskalkulation, Arbeitsvorbereitung, Zuschnittoptimierung, Zeichnungserstellung bis hin zur Steuerung der Profilsäge. Auch auf diesem Gebiet werden unsere Verarbeiter in die Anwendung eingeführt. Durch aktuelle Infos halten wir unsere Kunden in Technik und Normung auf dem laufenden.

In the following, we confine ourselves to some essential hints:

- *Remove slight soiling with water containing a neutral cleaning agent (no soapsuds!) using sponge and cloth, thereafter rinse thoroughly with clear water.*
- *Stronger soiling requires slightly abrasive acting cleaning agents which, however, should not be used on glass.*
- *For coated surfaces, we recommend to test the agents on a concealed surface to make sure that the agents do not attack lacquer either mechanically or chemically.*
- *By no means use cleaning agents with pH-values below 5 and above 8 as well as abrasive or sanding agents or steel wool and wire brushes.*

11. Maintenance of WICONA structural components

As far as there are no malfunctions or damages caused by improper handlings, the maintenance by the private house owner can be restricted to slightly oiling or greasing accessible gliding fitting parts at larger intervals. Maintenance works on larger projects and public buildings should be carried out by professionals, especially when they are connected with further preservation measures.

In this case, the fabricator can assure the quality of his work over a long period of time and the satisfaction of his client by concluding a maintenance contract with the building owner.

12. Functional capability

WICONA windows fulfil the requirements with regard to air permeability (EN 12207), water tightness (EN 12208), resistance to wind load (EN 12210) and the guidelines of Gütegemeinschaft Aluminiumfenster (Association for quality mark of aluminium windows). System test reports are available, as well as test certificates for sound insulation, assault resistance and smoke tightness of doors. As a rule, the sealing and drainage systems of the represented series will work correctly only when installed vertically.

Please revert in case of doubt.

In combination with appropriate insulation glazing, especially heat protecting glass, WICONA windows and casement doors comply with the requirements of the energy saving ordinance 2009.

The classification of our thermally insulated WICONA systems according to EN ISO 10077-1(2) can be found in our documentation.

Based on this classification and the U_g -values supplied by the glass manufacturers, the U_w -values for glazed windows and casementdoors can be calculated.

13. Technical service performances

Our planning documents and technical drawings, workshop manuals and fittings installation plans facilitate processing of our systems. Furthermore, the support services of WICONA and of our distribution partner are at your disposal. Our documents and services are provided to the best of our knowledge. However, we cannot assume liability for correctness except for errors based on intent or gross negligence on our part.

We offer trainings for our system fabricators on site or seminars of several days' intensive theoretical and practical instructions in metal construction at our Technology Centre. Our PC-Software packet WICTOP/WICPLOT offers a variety of possibilities of modern data processing for tender estimating, work scheduling, optimization of profile cutting, drafting and even control of profile saw. Our fabricators are also introduced into this field of application. We keep our customers updated with regard to the latest technique and standards through continuous informations.

14. Werksgarantie

Den Verarbeitern unserer wärmegeprägten Fenstersysteme bieten wir eine Garantie über die Einhaltung einer Reihe der in dieser Liste gemachten Angaben.

Die Garantieerklärung stellen wir dem Verarbeiter auf Anforderung gern zur Verfügung.

Wir weisen darauf hin, dass die Garantie erlischt, sofern andere als die im jeweils gültigen WICONA-Lieferprogramm aufgeführten Profile, Zubehörteile und Beschläge verwendet werden. Der gleiche Vorbehalt gilt als Haftungsausschluss sinngemäß auch für unsere nicht wärmegeprägten Systeme.

15. Warenzeichen WICONA

Verschiedene Profile und Konstruktionen des WICONA-Programms sind patentrechtlich geschützt.

In unseren Technischen WICONA-Unterlagen sind die Ergebnisse unserer Entwicklungsarbeit, unsere Erfahrungen und unser Fachwissen als Systemhersteller eingebracht. Die Wiedergabe des Inhalts dieser Liste wie auch des Inhalts unserer anderen Unterlagen ist deshalb nur mit unserer schriftlichen Genehmigung und unter Benutzung unseres Warenzeichens WICONA mit dem Hinweis gestattet:

® = eingetragenes Warenzeichen der Sapa Building Systems GmbH, Ulm.

Die Benutzung dieses Warenzeichens zu Werbezwecken oder als Produktbezeichnung ist nur zulässig, sofern ausschließlich Profile, Zubehörteile und Beschläge des jeweils gültigen WICONA-Lieferprogrammes vorgesehen oder verwendet worden sind. Wer also WICONA-Konstruktionsteile ganz oder teilweise mit fremden Konstruktionsteilen verarbeitet, ist nicht zur Benutzung unseres Warenzeichens berechtigt. Insbesondere dürfen mit fremden Konstruktionsteilen hergestellte Bauteile nicht gegenüber Architekten, Bauherren usw. als „WICONA-Fenster, -Türen“ oder ähnlich bezeichnet werden. Änderungen von Profilen, Zubehörteilen, Beschlägen und Konstruktionen bleiben vorbehalten. Angegebene DIN-Normen werden sinngemäß von den WICONA-Landesorganisationen in landesübliche Normen und Richtlinien übertragen.

16. Beschläge

Beschläge und vergleichbare Bauteile sind gemäß den zu erwartenden Belastungen und unseren Angaben dimensioniert und durch Nanosil-Qualität verstärkt gegen Korrosion geschützt (Schutzklasse 5 nach EN 1670:2007). Der Verarbeitungsbetrieb wählt nach zulässigen Beanspruchungen unsere Beschläge aus. Wartung beweglicher Beschlagteile gegen Verschleiß und Korrosionsanfälligkeit sowie Häufigkeit der Reinigung und Pflege sind entsprechend den Anforderungen mechanischer und chemischer Belastungen aus der Umgebung durchzuführen. Alle Abbildungen sind DIN R dargestellt.

Gütesicherung der Beschläge:

Notwendige Güteeigenschaften für

- Fenster und Fenstertüren nach RAL-RG 636/1 und RAL-RG 716/1 bewertet. Dauerfunktionstüchtigkeit, Korrosionsschutz, Leichtigkeit, Bedienbarkeit usw. von Dreh- Kipp-Beschlägen nach europäischer Norm EN 13126-8 beurteilt.
- Türen- und Spezial-Beschläge nach Anforderungen der VOB-Teil C, DIN 18357 und den jeweiligen EN-Prüfungen.

14. Factory guarantee

We offer the fabricators of our thermally insulated window systems a guarantee with regard to the compliance with the sequence of specifications made in this programme list.

This guarantee declaration is provided to fabricators on request.

We would like to point out that the guarantee becomes void if other profiles, accessory parts and fittings than the ones listed in the valid WICONA product range are used.

The same conditions also apply to our non thermally broken systems.

15. WICONA Trademark

Several profiles and constructions of the WICONA Programme are protected by patent rights.



Our technical WICONA documents include results of our development work, our experiences and our specialized knowledge as system producer. Hence, reproduction of contents of this list as well as contents of our other documents is only allowed

with our written permission and using our trade mark WICONA with the indication:

® = Registered trade mark of Sapa Building Systems GmbH, Ulm.

The use of this trade mark for advertising purposes or as product name is only admissible provided that profiles, accessories and fittings exclusively out of the respective, valid WICONA product range are used or intended to be used. Fabricators using WICONA components partially or exclusively in conjunction with foreign components is not entitled to use our trade mark. Particularly, structural components fabricated with external constructions parts should not be designated as „WICONA windows and doors“ or similar towards Architects, Building owners etc. We reserve the right to alter profiles, accessory parts, fittings and constructions. The specified DIN standards are transferred by the local WICONA organizations into local customary standards and guidelines.

16. Fittings

Fittings and comparable structural components are dimensioned according to the expected loads and our specifications and are highly protected against corrosion through Nanosil quality coating (protection class 5 to EN 1670:2007). The fabricating company selects our fittings according to the admissible loads. Maintenance of movable fitting parts against wear and corrosion as well as frequency of cleaning and maintenance should be performed depending on the requirements regarding mechanical stress and chemical attacks from the surroundings. All displayed pictures are DIN R.

Quality assurance of fittings:

Necessary qualitative properties for:

- windows and casement doors according to RAL*-RG 636/1 and RAL*-RG 716/1. Evaluation of long term functionality, corrosion protection, soffit test, operability etc. of turn/tilt fittings according to European Standard EN 13126-8.
- Doors and special fittings according to requirements of VOB (German construction contract procedures), Part C, DIN 18357 and the respective EN tests.

Für die Vielzahl von Tür-Beschlag-Einzelteilen gelten eine Reihe von Normen wie die RAL-RG 607/8-3 ausweist.

Geltende Regelwerke sind mit dem ÜZ (Übereinstimmungsnachweis) belegt. Genannte Normen in der Bauregelliste, wie DIN EN 1627 für einbruchhemmende Türen, bestimmen die Qualität der jeweiligen Bauprodukte. Für die Sicherheitstechnik wie Rauch- und Feuerschutzelemente gelten neben den Normen die aktuellen Zulassungen und Prüfberichte.

Oberflächenschutz der Beschläge:

- Teile aus rostfreiem Stahl nach EN 10088-1, ohne Oberflächen-Behandlung.
- Teile aus Stahl mit Spezialverfahren oder nach EN 1403 verzinkt, chromatiert und zusätzlich mit verstärktem Korrosionsschutz beschichtet.
- Nichteisenmetalle: Alle sichtbaren Teile nach vereinbartem Farbmuster eloxiert bzw. beschichtet.

Die Oberflächenschutz-Vorschriften der Gütegemeinschaften werden eingehalten.

Anhang: Oberflächenbehandlung bei WICONA-Verbundprofilen

Bei unseren wärmegeprägten Verbundprofilen erfolgt die Verbindung der Aluminiumprofilschalen durch glasfaserverstärkte Polyamideleisten. Der Werkstoff dieser Leisten und das Verbindungsverfahren erlauben eine nachträgliche Oberflächenbehandlung der Profile nach dem heutigen Stand der Technik entsprechenden Eloxal- und Beschichtungsverfahren unter Einhaltung bestimmter Bearbeitungsbedingungen.

1. Aufrüsten

Die Wärmedämmzone darf nicht auf Druck, Zug, Biegung oder Torsion beansprucht werden. Ein Durchhängen der Profile muss gegebenenfalls durch zusätzliche Unterstützung abgefangen werden. Die Kontaktierung beim Beschichten muss an beiden Profilschalen und an beiden Stabenden, also insgesamt vierfach, erfolgen.

2. Vorbehandlung

Die in der Praxis gebräuchlichen Vorbehandlungen beim Eloxieren nach EN 12373 bzw. das dem Farbbeschichten vorausgehende Chromatieren nach DIN EN 12487 schädigen unsere Verbundprofile nicht. Auf folgende Punkte weisen wir besonders hin:

- Überbeizen muss wegen seiner Auswirkungen auf den Verbund vermieden werden.
- Zwischen den einzelnen Behandlungsstufen muss gründlich gespült werden, um Korrosion durch Badrückstände in den Verbindungszonen und in den Profilhohlkammern auszuschließen.
- Die Objekttemperatur bei Haftwassertrocknung darf 100 °C nicht überschreiten.

3. Grenzbedingungen bei Pulverbeschichtung

Bei der Aushärtung darf die am Profil im Ofen zu messende Objekttemperatur 200 °C über 15 Minuten nicht überschreiten. Die Einhaltung dieser Bedingungen ist durch Aufzeichnungen regelmäßig zu dokumentieren.

Number of Standards included in RAL-RG 607/8-3 are valid for a variety of door fitting components.

The prevailing regulations are covered by ÜZ (conformity evidence mark). The Standards listed in the list of building rules, such as DIN EN 1627 for burglary resistant doors determine the quality of respective building products. For the safety technique such as smoke control and fire protection units, besides the standards, the current approvals and test reports are valid.

Surface protection of fittings:

- *Parts made of stainless steel according to EN 10088-1 without surface treatment.*
- *Parts made of steel with special procedure or galvanized, chromated and additionally corrosion protection coated according to EN 1403.*
- *Nonferrous metals:
All visible parts anodized or coated according to stipulated colour sample.*

The surface protection regulations of Association for quality mark are complied with.

**: German Institut for Quality Assurance and Certification*

Appendix: Surface treatment of WICONA composite profiles

The aluminium profile shells of our thermally insulated composite profiles are connected with glass fibre reinforced polyamide strips. The material of these strips and connecting procedure allow a subsequent surface treatment of profiles corresponding to the latest technologically developed procedures of anodizing and coating, complying with certain processing conditions.

1. Equipment

The thermal insulation zone should not be stressed by pressure, traction, deflection or torsion. When necessary, sagging of profiles must be intercepted by additional support. For coating, electrodes must be placed on both profile shells and on both profile bar ends, i.e. totally fourfold contacts.

2. Pretreatment

The customary pre-treatment for anodizing according to EN 12373 or the preceding chromating according to DIN EN 12487 for colour coating in the practice does not damage our composite profiles.

Refer particularly to the following points:

- *Due to its effect on composite zone, the over pickling should be avoided.*
- *Rinse thoroughly between individual treatment stages to avoid corrosion through bath residues in connecting zones and in profile hollow chambers.*
- *The object temperature during the drying period of adhered water should not exceed 100 °C.*

3. Marginal conditions for powder coating

The maximum hardening temperature of profile in the furnace should not exceed 200 °C during 15 minutes. Compliance with these conditions should be documented regularly through records.

4. Entlacken/Wiederbeschichten von Verbundprofilen

Auf Grund bisheriger Erfahrungen mit Polyamidleisten halten wir eine einmalige Entlackung und Wiederbeschichtung für möglich. Für Isolierleisten aus anderen speziellen Kunststoffen gilt diese Aussage nicht. Bei Isolierleisten aus speziellen Kunststoffen ist vor dem Entlacken die Verträglichkeit der Entlackungsmittel vom Entlackungsbetrieb zu prüfen. Die Verantwortung für eine ordnungsgemäße Entlackung und Wiederbeschichtung liegt ausschließlich beim Entlackungsbetrieb. Sie sollte sich jedoch auf Ausnahmefälle beschränken.

Folgendes ist dabei zu beachten:

Zum Entlacken dürfen nur solche Chemikalien verwendet werden, die nachweislich Polyamid nicht angreifen. Mittel, die z.B. Ameisensäure enthalten, sind daher auszuschließen. Tragglieder nach DIN 18056 (Rahmen, Riegel, Pfosten) sollten nicht wieder beschichtet werden. Vor dem erneuten Beschichten muss das Verbundprofil mindestens 24 Stunden bei Raumtemperatur zwischengelagert werden. Unsere WICONA-Werksgarantie gilt nicht für solchermaßen mehrmals oberflächenbehandelte Profile.

4. Stripping and re coating composite profiles

Based on our past experiences with polyamide strip, we consider the possibility of stripping and re-coating only once. This predication does not apply to thermal break strips made of other special plastic materials. The compatibility for lacquer stripping agents should be checked by the stripping company for insulation strips made of special plastic prior to stripping lacquer. The stripping company is wholly responsible for proper stripping and re-coating.

However, it should be limited to exceptional cases.

Thereby, following has to be considered:

Only approved chemicals which do demonstrably not attack polyamide should be used for stripping. Agents containing formic acid for instance should not be used. Load bearing elements (frame, transom, mullion profiles) according to DIN 18056 should not be re-coated again. The stripped composite profile must be stored at room temperature for at least 24 hours prior to re-coating.

Our WICONA factory guarantee is not valid for profile surface treated several times in such a way.

Werkstoff-Kenndaten / Material data specifications

Aluminium EN AW-6060 T66 (AlMgSi0,5 F22)
DIN EN 573, DIN EN 755

Dichte / Density	ρ	2,7 g/cm ³	(2700 kg/m ³)
Zugfestigkeit / Tensile strength	R_m	21,5 kN/cm ²	(215 MPa)
Mindeststreckgrenze / Minimum yield strength	R_e	16,0 kN/cm ²	(160 MPa)
Längenausdehnungskoeffizient / Linear expansion coefficient	α	23,5 x10 ⁻⁶ /K	
E-Modul / Modulus of elasticity	E	7000 kN/cm ²	(70000 MPa)
Wärmeleitfähigkeit / Thermal conductivity	λ	160 W/mK	
- σ : im Lastfall H / for load combination H DIN 4113-1/A1		8,8 kN/cm ²	(88 MPa)
- σ : im Lastfall HZ / for load combination HZ		10,0 kN/cm ²	(100 MPa)
- τ : im Lastfall H / for load combination H		5,0 kN/cm ²	(50 MPa)
- τ : im Lastfall HZ / for load combination HZ		5,8 kN/cm ²	(58 MPa)

WICSLIDE

Auswahl der Beschläge und Zubehörteile

Selection of hardware and accessory parts

Hinweis

Gewährleistung und Oberflächenschutz

Der Oberflächenschutz entspricht den Vorgaben der EN 1670. Eine Gewährleistung für die Oberflächenqualität wird dann übernommen, wenn keine aggressiven Stoffe den Beschlag angreifen (z.B. in Molkereien und an der Meeresküste), säurevernetzende Dichtstoffe, Kalk usw. Die Gewährleistung beginnt mit dem Tag, an dem der Beschlag eingebaut wird. Im Gewährleistungsfall leisten wir kostenlosen Ersatz der defekten Teile. Weitere Kostenerstattungen unsererseits sind ausgeschlossen.

Oberflächenbehandlung

Sichtbare Beschlagsteile werden in den Standard-Beschichtungen Farbe silber eloxiert bzw. RAL 9016 oder RAL 9005 (schwarz) beschichtet oder blank angeboten.

Zulässige Flügelgrößen

Die im Beschlageteil angegebenen maximalen Breiten und Höhen gelten nur für die Anwendungsbereiche der Grundbeschläge. Durch unterschiedliche Flügelprofile und der angenommenen Windlast sowie Schema-Anordnungen werden diese Flügelgrößen eingeschränkt bzw. durch den Einsatz von optional zusätzlichen Beschlagteilen, wie z.B. Mittelverriegelungen, erweitert (siehe Tabellen "Zulässige Flügelgrößen"). Die profilabhängigen maximalen Flügelgrößen können durch die beschlagsabhängigen maximalen Formatgrößen eingeschränkt werden (siehe Tabellen "Zulässige Formatgrößen"). Sondergrößen und erhöhte Flügelgewichte können im Einzelfall mit zusätzlichen Beschlagskomponenten ausgeführt werden.

Hierzu ist die Anfrage bei WICONA erforderlich.

Mindestplatzbedarf

Zum Anbringen von Beschlagteilen muss bei der Auswahl der Blendrahmen der Mindestplatzbedarf und die Bohrlage der Beschlagteile berücksichtigt werden.

Hebe-Schiebe- / Schiebe-Beschlag

Das Breiten- / Höhenverhältnis darf nicht kleiner sein als 1:2,5.

Verarbeitung

Der Beschlageinbau und die Profilbearbeitung ist aus der jeweiligen, systembezogenen Verarbeitungsrichtlinie und den entsprechenden Beschlag-Einbauplänen zu entnehmen.

Ergänzende Hinweise

siehe WICSTYLE - Türbeschläge

siehe WICLINE - Fensterbeschläge

Bedienung und Wartung

Ergänzende Hinweise:

siehe Broschüre "Bedienungs- und Wartungsanleitung für Fenster, Türen und Fassaden-Elemente aus Aluminium."

Wichtige Hinweise zum Beschlag

Important indications on hardware

Note

Warranty and surface protection

The surface protection corresponds to the specifications of EN 1670 (European Standard). Warranty for surface quality will only apply if no aggressive material attacks the hardware (e.g. in dairies and coastal areas), such as acid polymerizing sealing compounds, lime etc. The warranty begins with the installation day of the hardware. In warranty cases, we replace defective parts free of charge. Further reimbursements of expenses on our part are excluded.

Surface treatment

Visible hardware parts are being offered silver anodized, resp. RAL 9016 or RAL 9005 (black) powder coated or raw.

Admissible sash sizes

The maximum width and height dimensions specified in the hardware chapter are only valid for the application areas of the standard hardware. By selecting different sash profiles in combination with assumed wind loads as well as opening schemes, these could be restricted, resp. extended through the use of optionally available supplementary hardware parts such as, for example, centre locking points (see table "Admissible sash sizes").

The profile dependent maximum sash sizes could be restricted through the hardware depended maximum format sizes (see table "Admissible format sizes"). Special sizes and increased sash weights can be accommodated individually using additional hardware components.

In such a case, please consult WICONA.

Minimum space required

When selecting the frame profiles, please take into account the minimum space required for mounting the hardware parts as well as the drilling position of the hardware parts.

Lifting sliding / sliding hardware

The width to height ratio should not be less than 1:2.5.

Processing

Please refer to the respective system specific processing guidelines and corresponding hardware installation plan for installation of hardware and the processing of profiles.

Additional information

see WICSTYLE - door hardware

see WICLINE - window hardware

Operating and maintenance

Additional information:

see booklet "Operating and maintenance instructions for aluminium windows, doors and façade units"

WICSLIDE

Auswahl der Beschläge und Zubehörteile
Selection of hardware and accessory parts

Produkthaftung

Allgemein

Die aufgeführten Beschläge und Zubehörteile mit RZ-Lochungen gelangen nur im Schweizer Markt zum Einsatz.

Die Lieferung der Rundzylinder sind Bestandteil der bauseitigen Schließsysteme bzw. der Sicherheitskonzepte.

Zylinderlochung

Hinweis:

PZ = Profilzylinder

RZ = Rundzylinder

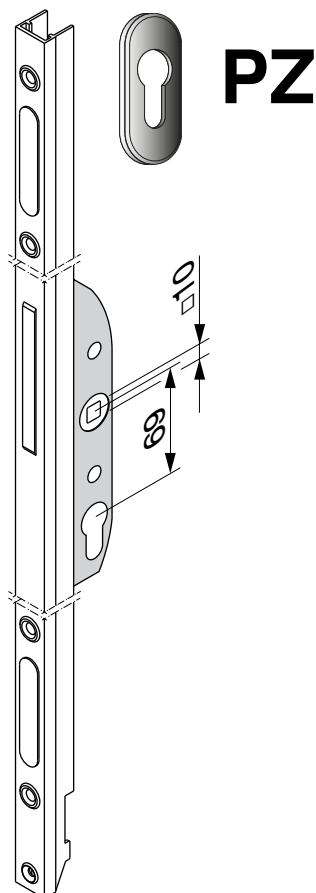

Wichtige Hinweise zum Beschlag *Important indications on hardware*

Product liability

General

The specified hardware and accessory parts with round cylinder are only used for the Swiss market.

The supply of the round cylinders is part of the site locking systems and safety concepts.

Punched hole for cylinder

Note:

PZ = profile cylinder

RZ = round cylinder

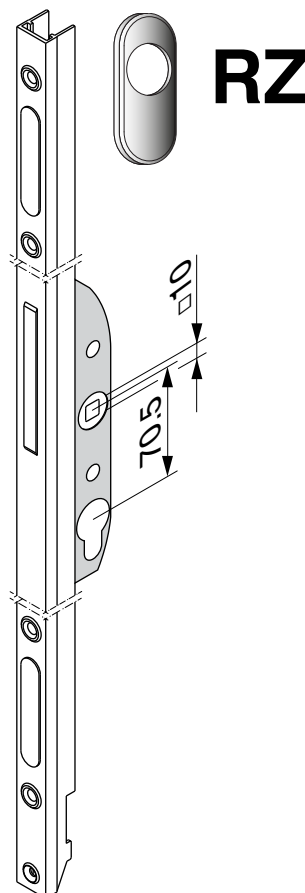

Verarbeitung

Hinweis:

Der Beschlageinbau und die Profilmontage ist aus der jeweiligen systembezogenen Verarbeitungsrichtlinie zu entnehmen.

Weitere Beschläge finden Sie in der WICONA Standard-Programmliste.

Processing

Note:

Please refer to the respective system specific guidelines regarding hardware installation and profile processing. Further hardware can be found in the WICONA standard program list.

Öffnungsart Opening type

Hebe - Schiebetür / -fenster
mit Festverglasung
*Lifting sliding door / window
with fixed glazing*

Hebe - Schiebetür / -fenster
Lifting sliding door / window

Zweibahnig Double track

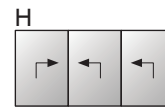
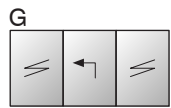
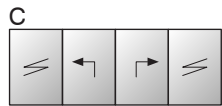
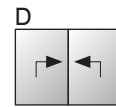
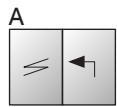









Dreibahnig Triple track



















WICSLIDE 160

Zulässige Flügelgrößen
Admissible sash sizes

Symbole / Hinweise
Symbols / Indications

Symbol <i>Symbols</i>	Bezeichnung <i>Designation</i>	Symbol <i>Symbols</i>	Hinweis <i>Indication</i>
	Windlast <i>Wind Load</i>		1000 Pa = 1 kN/m ² <i>1000 Pa = 1 kN/m²</i>
	Schlagregendichtheit <i>Tightness against driving rain force</i>		Diagramme zulässige Format- größen beachten <i>Mind diagrams admissible format sizes</i>
	Einbruchhemmung RC1 N/RC2N/RC2 DIN EN 1627:2011 <i>Burglary resistance class RC1 N/RC2N/RC2</i>		Profil-Nr. in () sind ohne Darstellung <i>Profile-No. in () are without picture</i>
	Maximal zulässiges Flügelgewicht <i>Maximum admissible sash weight</i>		
	Wichtiger Hinweis zu beachten! <i>Important hints pay attention to!</i>		

Profilseiten
Profile pages

Symbol Symbols	Bezeichnung Designation	Symbol Symbols	Bezeichnung Designation
	Profil-Außenschale <i>Profile outer shell</i>		Eckwinkel <i>Corner angle</i>
	Profil-Innenschale <i>Profile inner shell</i>		Hülse <i>Bush</i>
	Profilstablänge <i>Profile bar length</i>		Stoßverbinder <i>Butt-joint connector</i>
	Äußerer Umfang Eloxal, ohne Wärmedämmleisten <i>External perimeter Anodic, without thermal insulation strips</i>		Leitteil <i>Guide part</i>
	Mechanisch bearbeitbare Fläche <i>Mechanically processible surface</i>		Bohrschablone <i>Drilling template</i>
	Eckverbindung <i>Corner connection</i>		Handstanzwerkzeug <i>Hand punching tool</i>
	Stoßverbindung (Blendrahmen/ Kämpfer, Kämpfer/Kämpfer) <i>Butt-joint connection (Frame/Transom, Transom/Transom)</i>		Multifunktionsstanzwerkzeug <i>Multi-function punching tool</i>
	Stanzen <i>Punching</i>		Presstawerkzeugsatz <i>Crimping tool set</i>

Profilseiten
Profile pages

Symbol Symbols	Bezeichnung Designation	Symbol Symbols	Bezeichnung Designation
	Selbstzuschnitt Self-cut		Gelenkeckwinkel, vertikal Hinged corner angle, vertical
	Presstaverbindung Crimped connection		Stift Pin
	Al-Strangpresseckwinkel Extr. aluminium corner angle		Kegelschraube Conical screw
	Breite Selbstzuschnitt Width self-cut		Gelenkeckwinkel, horizontal Hinged corner angle, horizontal
	Gelenkeckverbindung Hinged corner connection		Gelenkverbindung Hinged connection
	Bohren Drilling		Gelenkverbinder Außenschale Hinged connector outer shell
			Gelenkverbinder Innenschale Hinged connector inner shell
	Hauptsichtfläche Main visible surface		Nebensichtfläche Secondary visible surface

WICSLIDE 160

Abkürzungsverzeichnis
List of abbreviations

Technische Information Technical Information

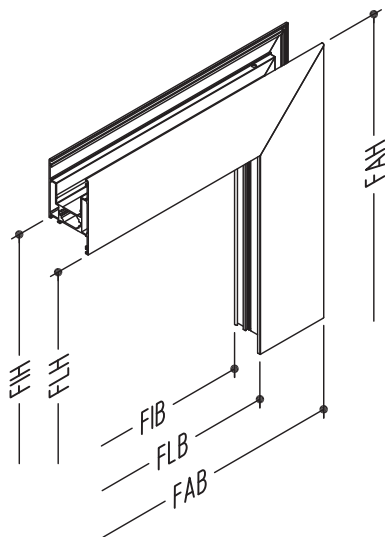
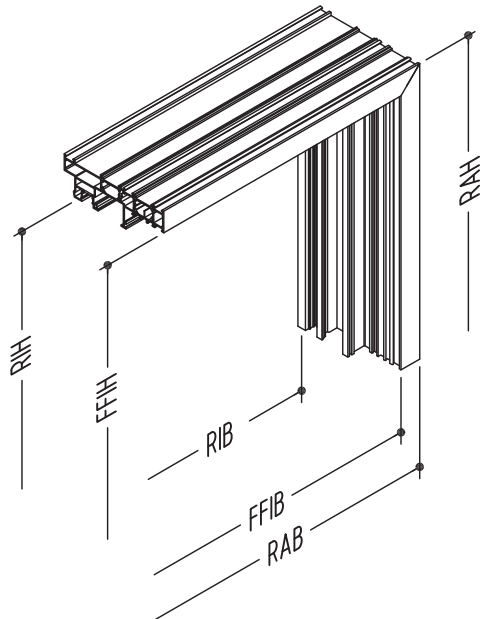

- RAB** Rahmen - Außenmaß - Breite
Frame outer width dimension
- RIB** Rahmen - Innenmaß - Breite
Frame inner width dimension
- FFIB** Festfeldrahmen - Innenmaß - Breite
Fixed field frame inner width dimension
- RAH** Rahmen - Außenmaß - Höhe
Frame outer height dimension
- RIH** Rahmen - Innenmaß - Höhe
Frame inner height dimension
- FFIH** Festfeldrahmen - Innenmaß - Höhe
Fixed field frame inner height dimension

- FAB** Flügel - Außenmaß - Breite
Sash outer width dimension
- FIB** Flügel - Innenmaß - Breite
Sash inner width dimension
- FLB** Flügel - Lichtmaß - Breite
Sash width clearance dimension
- FIH** Flügel - Innenmaß - Höhe
Sash inner height dimension
- FAH** Flügel - Außenmaß - Höhe
Sash outer height dimension
- FLH** Flügel - Lichtmaß - Höhe
Sash height clearance dimension

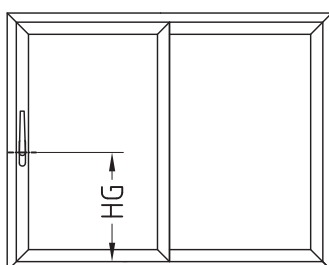

HG Höhe Griff
Height of handle

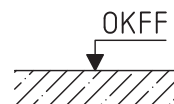

OKFF Oberkante Fertigfußboden
Top edge of finished floor

	Seite Page
Serienbeschreibung <i>Description of series</i>	2/3
Profilübersicht <i>Survey of profiles</i>	2/6
Blendrahmenprofile <i>Frame profiles</i>	2/15
Flügelprofile <i>Sash profiles</i>	2/24
Kämpfer, Sprossenprofile <i>Transom, glazing bar profiles</i>	2/25
Pfostenprofile <i>Mullion profiles</i>	2/26
Kupplungsprofile <i>Coupling profiles</i>	2/27
Abdeckprofile <i>Cover profiles</i>	2/28
Konstruktionsschnitte Übersicht - zweibahnig <i>Survey of construction sections - double track</i>	2/31
Anwendungsbeispiele <i>Examples of application</i>	2/33
Konstruktionsschnitte Übersicht - dreibahnig <i>Survey of construction sections - triple track</i>	2/61
Anwendungsbeispiele <i>Examples of application</i>	2/63
Glasleistenprofile - Auswahltabellen <i>Glazing bead profiles, selection tables</i>	2/74
Zulässige Flügelgrößen <i>Admissible sash sizes</i>	2/78
Beschlägeübersichten <i>Survey of hardware</i>	2/86

WICSLIDE 160 ist eine Konstruktion für wärmeisolierte Hebe-Schiebefenster- und -türen. Diese Serie zeichnet sich durch seine hohen Leistungen aus.

Hauptmerkmale:

- Blend- und Flügelrahmen auf Gehrung verbunden.
- Blendrahmen-Bautiefe 160 mm oder 245 mm.
- 1 Flügel mit 107 mm Ansichtsbreite und mittig angeordneter Dämmzone 35 mm.
- Hebe-Schiebe-Beschlag.
- Die Wärmedämmung erfolgt über Polyamid-Dämmstege (40 oder 35 mm), wärmebeständig bis 200°C / 15 Minuten.
- Erhöhte Wärmedämmung über in die Hohlkammern des Flügelprofils und in den Glasfalz eingebrachte Isolierschaumstreifen.

Öffnungsarten:

Hebe-Schiebefenster und -türen

- Schema A + D
- Schema C + F
- Schema G + H
- Schema G3 + H3
- Schema I + J
- Schema K+L
- Schema M + N

Leistungen:

Große Abmessungen:

- Max. Abmessungen pro Flügel: 3.2 m Breite x 3.4 m Höhe
- Max. Flügelgewicht bis zu 400 kg

Wärmedämmung:

Uf-Werte gemäß EN ISO 10077-2

- $U_w < 1.6 \text{ W/m}^2\text{K}$ mit $U_g = 1.2 \text{ W/m}^2\text{K}$ für ein Element mit 4500 mm x 2300 mm Höhe
- $U_w < 1.1 \text{ W/m}^2\text{K}$ mit $U_g = 0.6 \text{ W/m}^2\text{K}$ (Dreifachverglasung) für ein Element 4500 mm x 2300 mm Höhe

Schalldämmleistungen:

Gemäß DIN EN ISO 717-1

Öffnungsart Schema A

- $R_w (C; C_{tr}) = 47 (-1; -5) \text{ dB}$ mit Mehrscheiben-Isolierglas Fa. AGC 16 VSG / 15 Argon / 12 VSG, Verbundscheiben mit Akustikfolie, Verbundprofile mit Beschwerung und Füllung gemäß Prüfbericht PB-A01-04-de-01 ift Rosenheim

Systemprüfungen:

Luftdurchlässigkeit EN 12207: Klasse 4

Schlagregendichtheit EN 12208: 9A (600 Pa) / E 750

Widerstandsfähigkeit bei Windlast EN 12210: C3

Blendrahmenprofile:

Profile mit 160 mm Bautiefe:

- Blendrahmen 2-bahnig oder 1-bahnig + Festverglasung mit oder ohne Wasser-Auffangrinne innen.

Profile mit 245 mm Bautiefe:

- Blendrahmen 3-bahnig oder 2-bahnig + Festverglasung mit oder ohne Wasser-Auffangrinne innen.

Wärmedämmung:

- mittels doppeltem, flächenbündigem Polyamid-Dämmsteg zur Vermeidung von stehendem Wasser.
- Umlaufendes PVC-Dämmprofil.
- Geklipptes Aluminium-Nutabdeckprofil sorgt für eine glatte Oberfläche und Integration der Schließbleche.
- Wetterschenkelprofil im oberen Bereich angeschraubt.

WICSLIDE 160 is a range of lift and slide windows and patio doors with thermal break. This range is characterized by its high performances.

Main characteristics:

- Frames and sashes in mitre cut assembly
- 160 mm or 245 mm frames depth.
- 1 sash of 107 mm sight line and 35 mm centered thermal break
- Lift and slide hardware.
- Thermal break is achieved by polyamide strips (40 or 35 mm), heat resistant up to 200°C / 15 minutes.
- High insulation version through inserted foam profiles in sash profile chambers and glazing rebate.

Opening types:

Lifting sliding doors and lifting sliding windows

- Scheme A + D
- Scheme C + F
- Scheme G + H
- Scheme G3 + H3
- Scheme I + J
- Scheme K+L
- Scheme M + N

Performance:

Large dimensions:

- Max. dimension per leaf: 3.2 m width x 3.4 m height
- Max. weight per leaf up to 400 kg

Thermal performance:

Uf values according to EN ISO 10077-2

- $U_w < 1.6 \text{ W/m}^2\text{K}$ with a $U_g = 1.2 \text{ W/m}^2\text{K}$ on a 4500 x 2300 mm height element
- $U_w < 1.1 \text{ W/m}^2\text{K}$ with a $U_g = 0.6 \text{ W/m}^2\text{K}$ (triple glass) on a 4500 x 2300 mm height element

Acoustic performance:

According to DIN EN ISO 717-1

Scheme A opening type

- $R_w (C; C_{tr}) = 47 (-1; -5) \text{ dB}$ with insulating glass unit co. AGC 16 LSG / 15 Argon / 12 LSG, Laminated sheet glass with acoustic foil, Compound profiles with weighting and infill according to test report PB-A01-04-de-01 ift Rosenheim

System testings:

Air permeability EN 12207: Class 4

Watertightness EN 12208: 9A (600 Pa) / E 750

Resistance to wind load EN 12210: C3

Frames profiles

160 mm depth profiles:

- Double track or single track frames with fixed glazing with or without inner water groove

245 mm depth profiles:

- Triple track or double track frames with fixed glazing with or without inner water groove.

Thermal break:

- Achieved with a double flush polyamide strip preventing water accumulation.
- Peripheral thermal PVC shield.
- Clipsed aluminium groove cover for a flush aspect and integrated striker plates.
- Weather bar profile to be fixed on top.

Zusammenbau:

- Gehrungsverbindung über Eckwinkel mit Schlaghülsen, Kegelschrauben oder Presstastanzung, mit Klebereinspritzung (Wicona-Patent).

Dichtigkeit:

Dampfdruckausgleich und Entwässerung:
Es gelten die üblichen Regeln für Dampfdruckausgleich und Entwässerung:

- Entwässerungsabdeckkappen und -teile mit Rückflusssperre.
- Verstärkte Dichtsperrle oben und unten.

Einbau:

- für Renovierungen und neue Gebäude.
- Zusätzliche Sims – Abdeckprofile.

Laufschiene:

- Edelstahl-Laufschiene.

Flügel:

- 65 mm Profiltiefe mit 35 mm Wärmedämmstegen.
- 1 Flügel mit 107 mm Ansichtsbreite.
- Falzhöhe 22 mm.
- Doppelte, flächenbündige Dämmstege zur Vermeidung von stehendem Wasser.
- 4-seitig umlaufendes Flügelprofil auf Gehrung, Zusammenbau mit doppeltem Eckwinkel, verbolzt, mit Presstastanzung oder Verschraubung, mit Klebereinspritzung (WICONA-Patent).
- ein spezielles PVC-Profil gewährleistet die Positionierung und Isolierung der Laufwagen und des Getriebes.
- Dämmschaumprofile im Flügel integriert bei hochwärmedämmender Ausführung.

Mittlere Verhakung:

- Standard oder verstärkt je nach Abmessungen und Beanspruchung des Elements.
- PVC-Verhakungsprofil, verschraubt und mit Dichtlippen.
- Unsichtbare Befestigung des Verhakungsprofil am Flügel.

Flügelstoß:

- mittlerer Flügelstoß mit Polyamid-Dämmprofil und dichtenden Endkappen.

Zubehör:

- Edelstahl-Schrauben.

Dichtigkeit:

- eine doppelte TPE-Dichtung mit Verklebung der Gehrungsstöße sorgt für Dichtigkeit zwischen Blendrahmen und Flügel.
- der Schließvorgang drückt bei geschlossenem Flügel die doppelten Dichtungen oben und unten sowie senkrecht an den Blendrahmen.
- das Flügeldichtteil oben, mit einem Balgsystem versehen (Wicona-Patent), sorgt für eine dauerhafte Dichtigkeit in der oberen Position des Flügels.
- das Flügeldichtteil unten, mit einer Dichtung versehen, sorgt für die Dichtigkeit in der unteren Position des Flügels.
- die Verhakungsprofile aus PVC sind mit einer koextrudierten Dichtungslippe versehen.
- die Aluminium-Aufsatzprofile mit Bürstendichtungen gewährleisten die Dichtigkeit des Verhakungsstoßes.

Optionen:

- Kämpfer, Sprosse
- Barrierefreie Schwelle in 2-bahniger Ausführung
- Zusatzprofil für verdeckte Entwässerung
- Kunststoff-Dämmauflagen für Bauanschluss

Assembly:

- *Mitre cut assembly by corner cleats with drive bushes / conical screws or crimped, with glue injection (Wicona patent).*

Tightness:

*Air pressure equalization and drainage:
The conventional rules for air pressure equalization and drainage to be applied:*

- *weep-hole covers and drains equipped with valves.*
- *Reinforced sealing barrier at the top and at the bottom.*

Installation:

- *Renovation or new building.*
- *Additional sill and architrave profiles.*

Sliding rail:

- *Stainless steel rail.*

Sash:

- *65 mm depth profile with 35 mm centered thermal break.*
- *1 sash of 107 mm sight line.*
- *Glazing rebate of 22 mm.*
- *Double flush polyamide strip preventing water accumulation.*
- *Mitre cut peripheral sash, assembly by corner cleats with drive bushes / conical screws or crimped, with glue injection (WICONA patent).*
- *Specific PVC adapter profile ensures position and insulation of the runners and gear box.*
- *Foam insulation profiles are integrated into the sash profile in the High Insulation version.*

Central baffle:

- *Single or reinforced according to the size of the frame and exposure of the window.*
- *A screwed PVC hooking profile with sealing lips.*
- *Hooking zone with concealed screws.*

Aligned sashes

- *Central locking sashes are ensured by an extruded polyamide profile and sealing end caps.*

Accessories:

- *Stainless steel screws*

Tightness:

- *Two mitre cut and glued TPE gaskets ensure the tightness between frame and sash.*
- *The locking action ensures the compression of the double gaskets on top and bottom of the sash profiles, and the compression of the vertical gaskets on the frame in closed position*
- *The top sash sealing part with shift system (Wicona patent) ensures a permanent sealing in high position.*
- *The bottom sash sealing part equipped with a gasket ensures the sealing in low position.*
- *The PVC baffles are extruded with a sealing lip.*
- *Brush gaskets on the supplementary sash profiles ensure the central mullion tightness.*

Options:

- *Transom, glazing bar*
- *Barrier-free threshold in 2 track version*
- *Additional profile for concealed drainage*
- *Thermal break profiles for junction to structure*

Füllungen:

- Innere und äußere Verglasungsdichtungen aus EPDM.
- Schaumdämmstreifen im Glasfalz.
- Punktuelle oder umlaufende Silikondichtung bei Einbruchhemmung RC 2N, RC 2.
- Befestigung der Füllung durch Glasleiste auf der Innenseite.
- PA Glasleiste auf Verhakungszone bei HI-Ausführung.
- Maximale Füllungsstärke 50 mm in Standardausführung.
- Maximale Füllungsstärke 47 mm in Ausführung mit Festverglasung
- die lokalen Verglasungsrichtlinien und -anweisungen sind zu beachten.

Betätigung und Verschlüsse:

Betätigung:

Das Beschlagsystem mit 2 Laufwagen übernimmt das Anheben des Flügels, löst den Kontakt der Dichtungen mit dem Blendrahmen und ermöglicht somit eine leichte Betätigung des Flügels.

- Positionierung der Laufwagen im unteren Flügelprofil in einem PVC-Profil.
- beim Schließen stützt sich ein Kunststoffteil des Laufwagens auf der Laufschiene ab und verhindert somit einen ständigen Kontakt der Laufrollen auf der Edelstahlschiene bei geschlossenem Flügel.
- eine im Laufwagen integrierte Bürste reinigt die Laufschiene bei der Betätigung.
- das 2 Laufwagen-System erlaubt ein maximales Flügelgewicht von 300 kg, 2 zusätzliche Laufwagen erlauben ein maximales Flügelgewicht bis 400 kg.
- die Verbindung zwischen den Laufwagen erfolgt mittels eines Verbindungsstabes, dessen Länge entsprechend der Flügelbreite angepasst werden muss.

Einbruchhemmung:

Gemäß DIN EN 1627: 2011.

Widerstandsklasse RC 1N, RC 2N, RC 2, für alle Öffnungsarten.

Verschluss:

- manueller Verschluss mit Getriebschloss mit durchlaufendem Stulp und Mehrfachverriegelung.
- Verriegelung mit 2 bis 5 Verriegelungspunkten in Abhängigkeit der Flügelhöhe.
- Aluminium-Schließbleche völlig flächenbündig im Blendrahmen integriert.
- Einfach- oder Doppelgriff mit 10 mm Vierkant.
- Standard-, Halb- oder Rundzylinder.
- Flügelanschlag oben und unten um ein Überkreuzen der Flügel zu verhindern.
- Zusätzliche Verschlüsse und Verriegelungen für Einbruchhemmung RC 1N, RC 2N, RC 2.
- Schloss-Anbohrschutz bei einbruchhemmender Ausführung.

Planungshinweise:

Um Beeinträchtigungen in der Funktion durch Sonneneinstrahlung oder hohen Differenzen zwischen Innentemperatur und Außentemperatur zu vermeiden, müssen Gebäudeausrichtung, Auswahl der Farbbeschichtungen und Elementgrößen berücksichtigt werden.

Abhilfe kann durch statische Verstärkung des Flügelprofils oder durch ein passendes Beschattungssystem erreicht werden.

Infills:

- EPDM gaskets inside and outside
- Glazing rebate foam profiles
- Punctual gasket or perimetral extruded sealing according to RC 2N, RC 2 burglar resistance test.
- Glass panel held in position by inside glazing bead
- PA glazing bead on central hooking zone baffle for HI version.
- Maximum glass thickness capacities: 50 mm
- Maximum glass thickness with fixed glazing: 47 mm
- Imperatively follow the local glazing regulations and directives of the glass industry.

Operation and locks:

Operation:

The double runners hardware system ensures the sash lifting, removes gasket pressure on the frame, and allows an easy sash opening.

- A PVC profile is clipped in the bottom transom to house the runners.
- In the closing position the runners are resting on plastic parts on the rail, thus avoiding a permanent contact of the wheels on the stainless steel rail.
- In operation, the integrated brush of the runners brush cleans the stainless steel rail.
- The double runners system allows a maximum weight of 300 kg per sash, 2 supplementary runners enable reaching 400 kgs per sash.
- The linking between the runners is ensured by a connecting rod well-adjusted to the sash width.

Burglar resistance:

According to DIN EN 1627: 2011.

Resistance classes RC 1N, RC 2N, RC 2, for all opening schemes.

Locking:

- Manual locking mechanism, closed gear box, with a multipoint locking plate.
- 2 or 5 locking points according to sash height
- Aluminum strikers are totally integrated in the frame for a flush aspect.
- Simple or double handles with a 10 mm square.
- Standard-, Semi- or Round cylinder.
- Stop at the top and bottom to avoid the sash crossing.
- Supplementary locking points for burglar resistance version RC 1N, RC 2N, RC 2.
- Gear anti drill protection for burglar resistance version.

Recommendations:

In order to avoid functional impairments caused by sun radiation or a high temperature gradient between inside and outside, building orientation, choice of colour coatings and element sizes should be taken into account.

Additional measures could be to strengthen the sash profile statically or to fit an appropriate shading device.

WICSLIDE 160

Profilübersicht Survey of profiles

Blendrahmenprofile Frame profiles

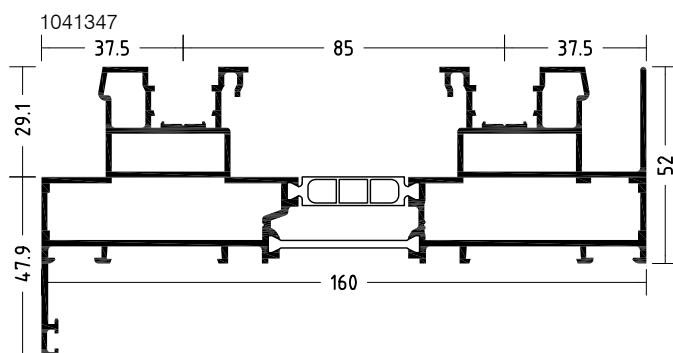
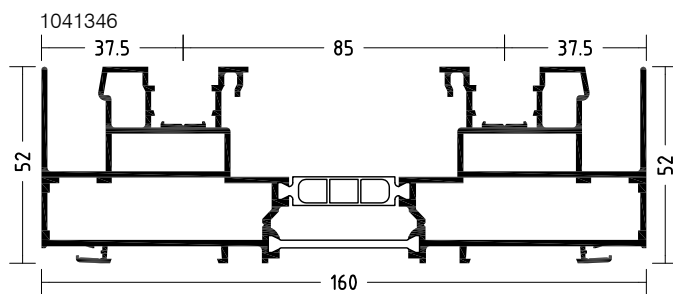
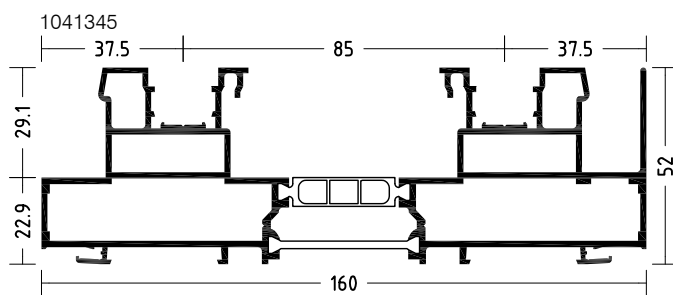
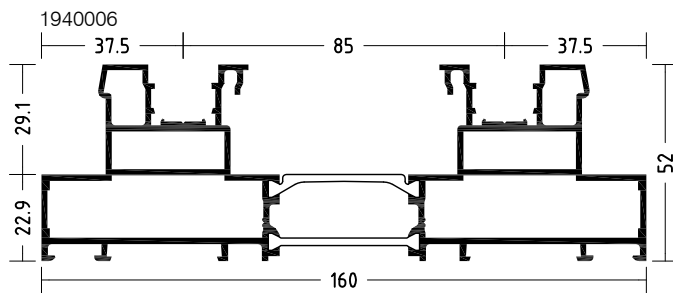

Profilübersicht
Survey of profiles

Blendrahmenprofile
Frame profiles

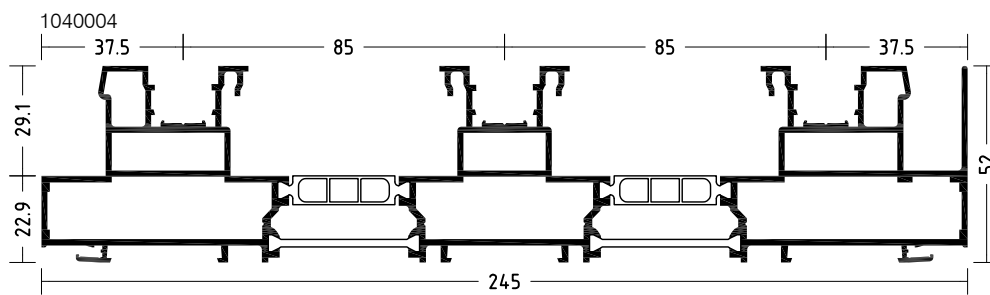
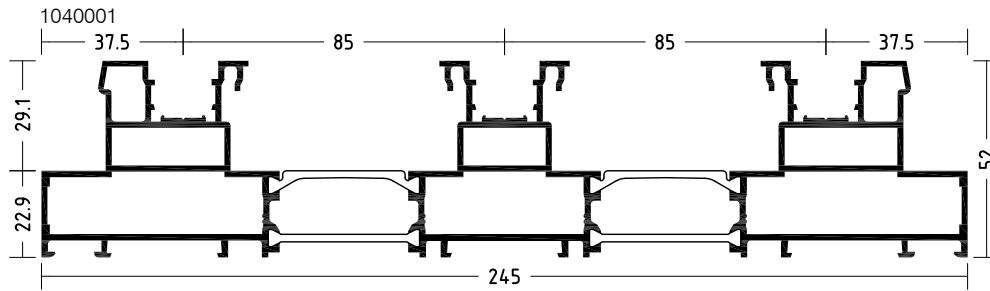

Profilübersicht
Survey of profiles

Flügelprofil
Sash profile

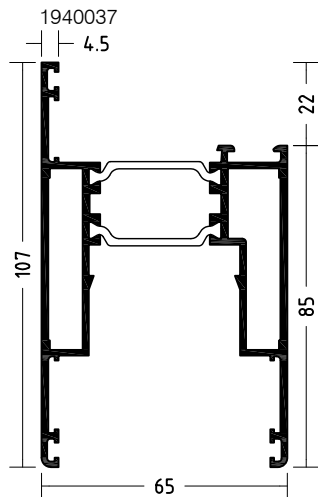

Kämpfer, Sprossenprofil
Transom, glazing bar profile

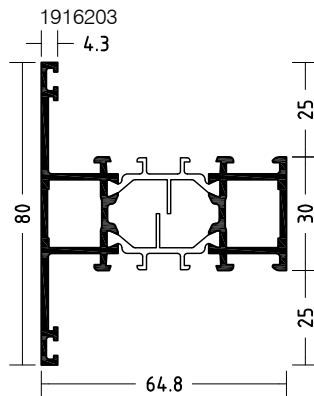

Verstärkungsprofile
Reinforcement profiles

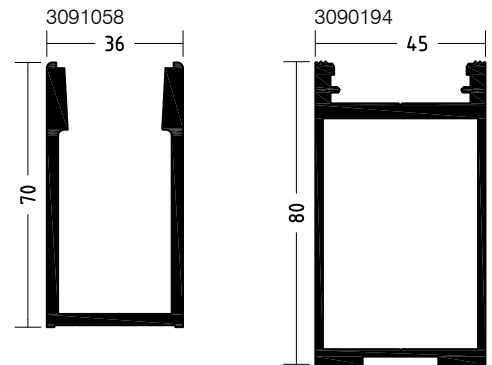

Abdeckprofile
Cover profiles

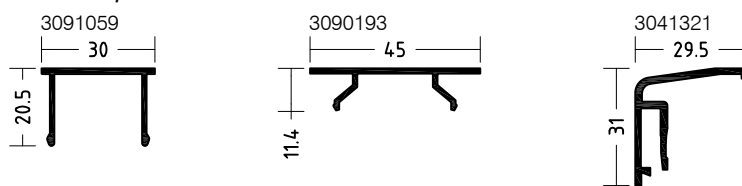

Zusatzprofile
Additional profiles

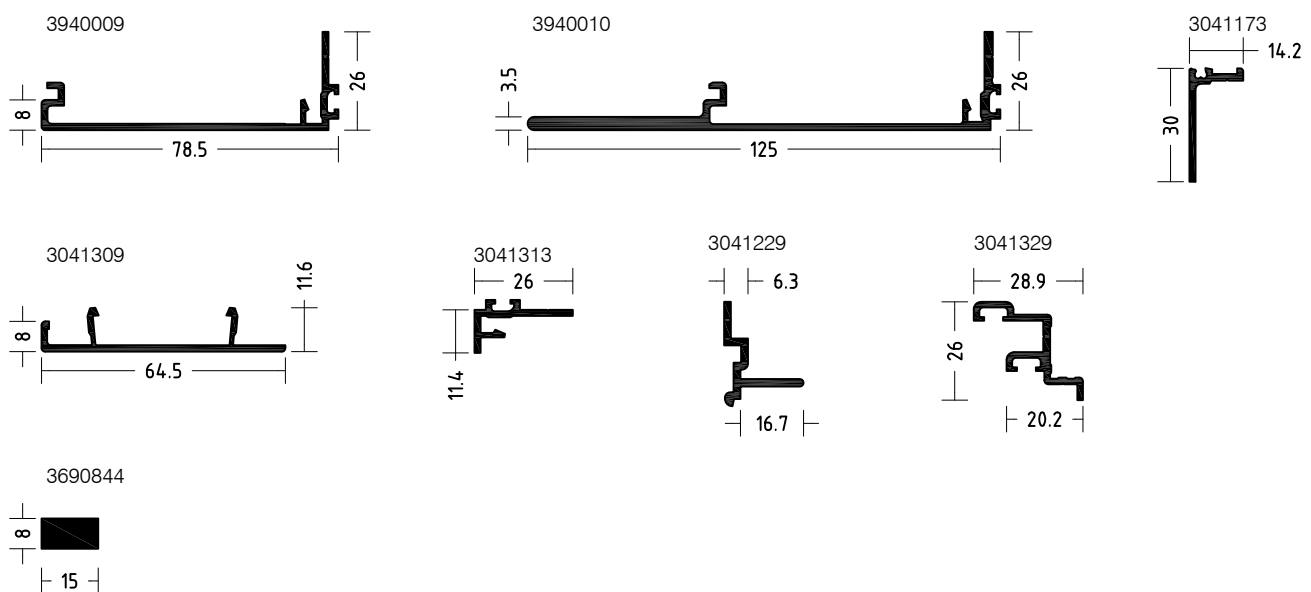

Profilübersicht
Survey of profiles

Abdeckprofile
Cover profiles

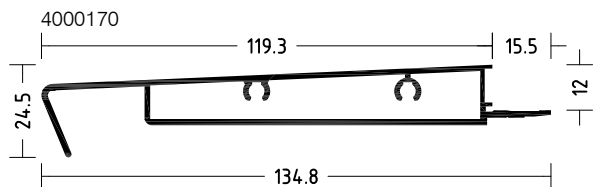
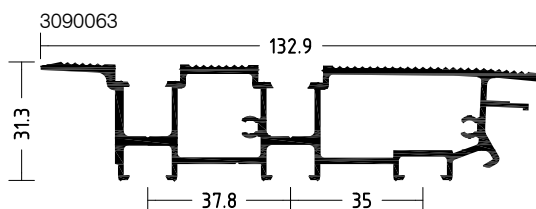
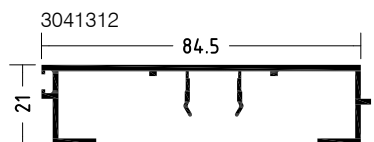
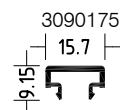
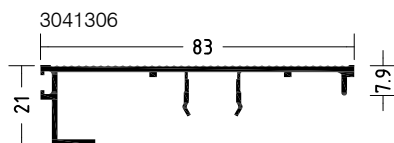
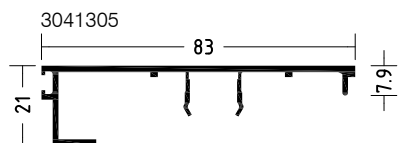
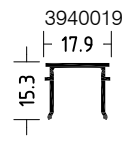
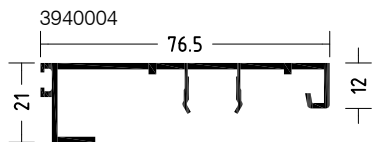
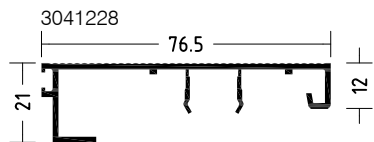

100 / 300 mm
 gelocht / punched

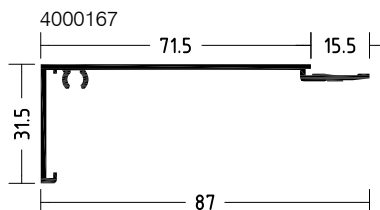

100 / 300 mm
 gelocht / punched

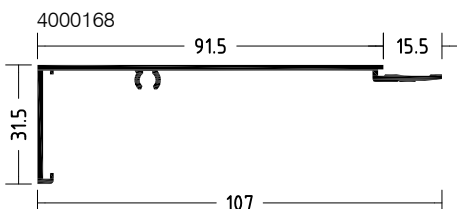

100 / 300 mm
 gelocht / punched

Profilübersicht
Survey of profiles

Verbindungsprofile
Connection profiles

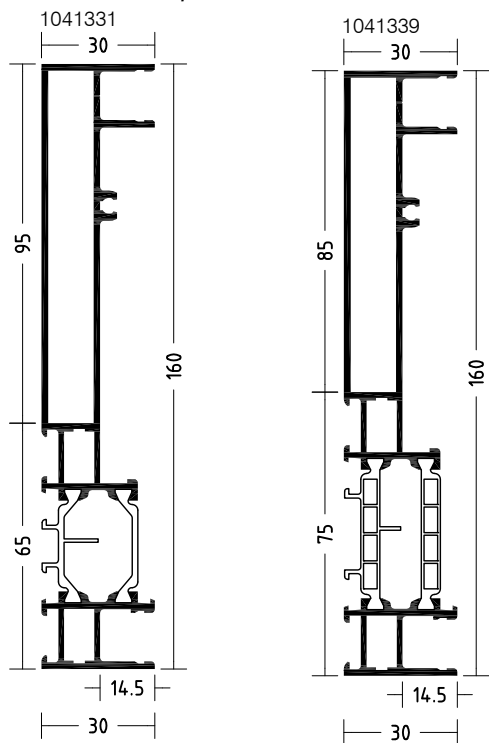

Zusatzprofile
Additional profiles

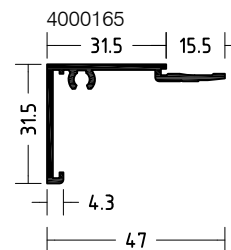
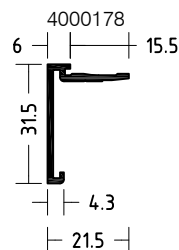
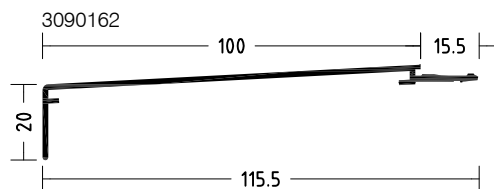
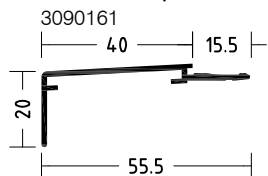

100 / 300 mm
 gelocht / punched

100 / 300 mm
 gelocht / punched

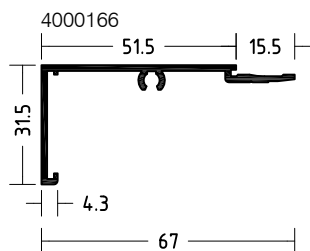

100 / 300 mm
 gelocht / punched

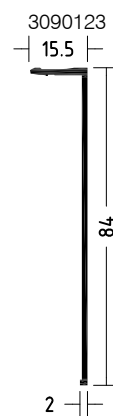
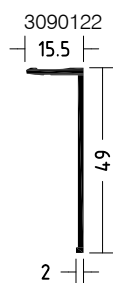
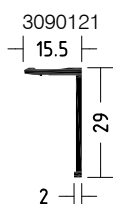
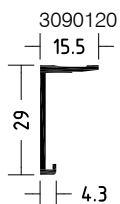

WICSLIDE 160

Profilübersicht Festverglasung Survey of profiles fixed glazing

Blendrahmenprofile

Frame profiles

1940019

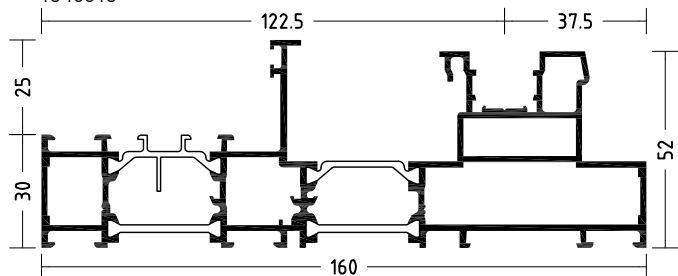

1041344

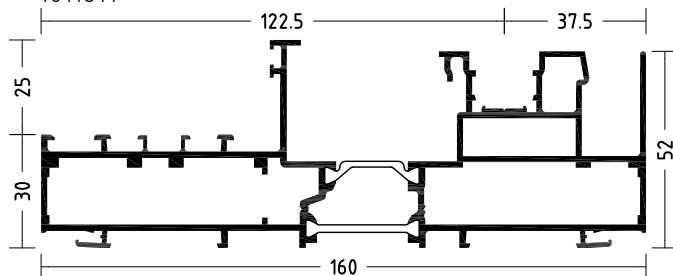

1040002

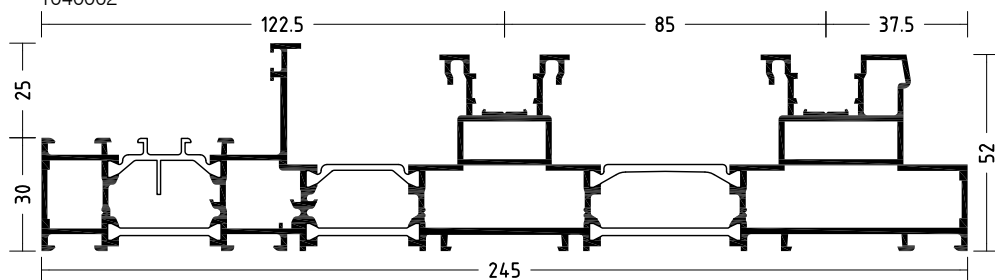

Pfostenprofile

Mullion profiles

1940041

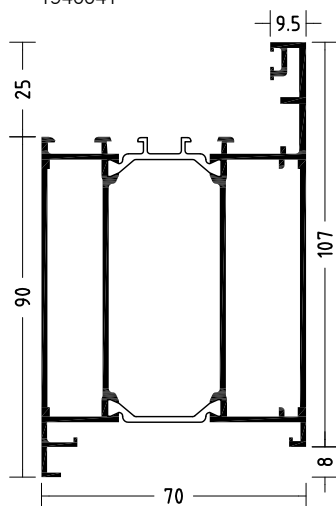

1040010

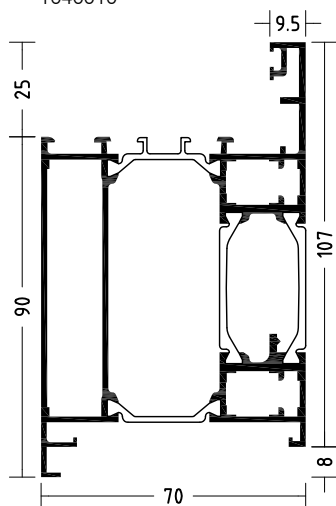

WICSLIDE 160

Profilübersicht Festverglasung Survey of profiles fixed glazing

Zusatzprofile

Additional profiles

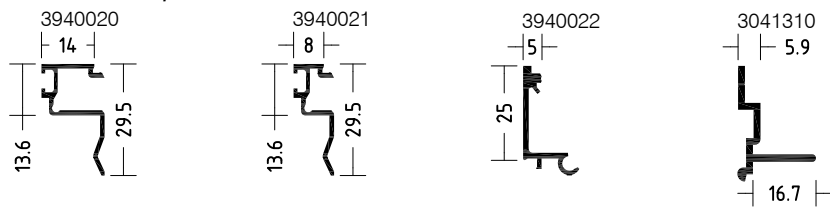

Abdeckprofile

Cover profiles

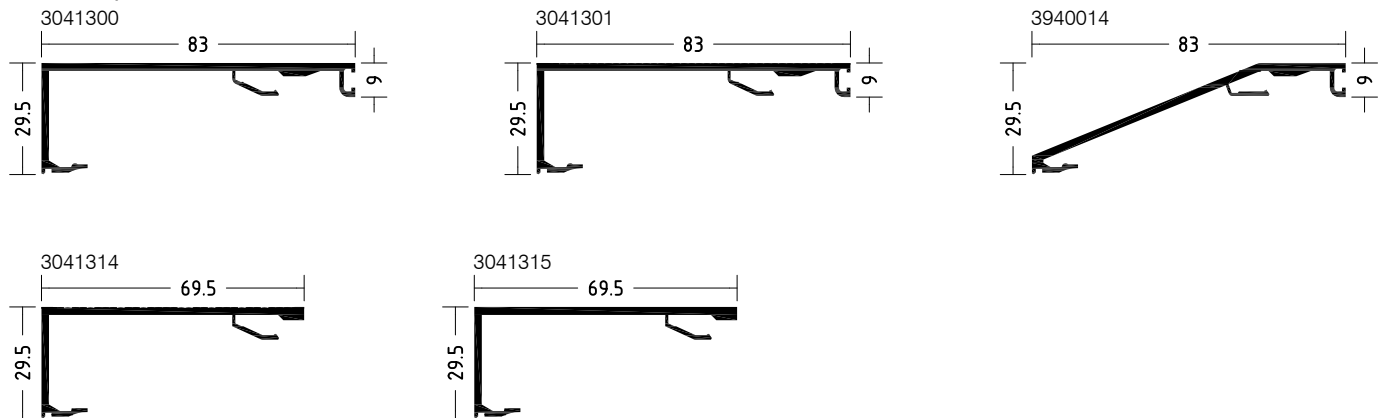

Profilübersicht
Survey of profiles

Glasleistenprofile
Glazing bead profiles

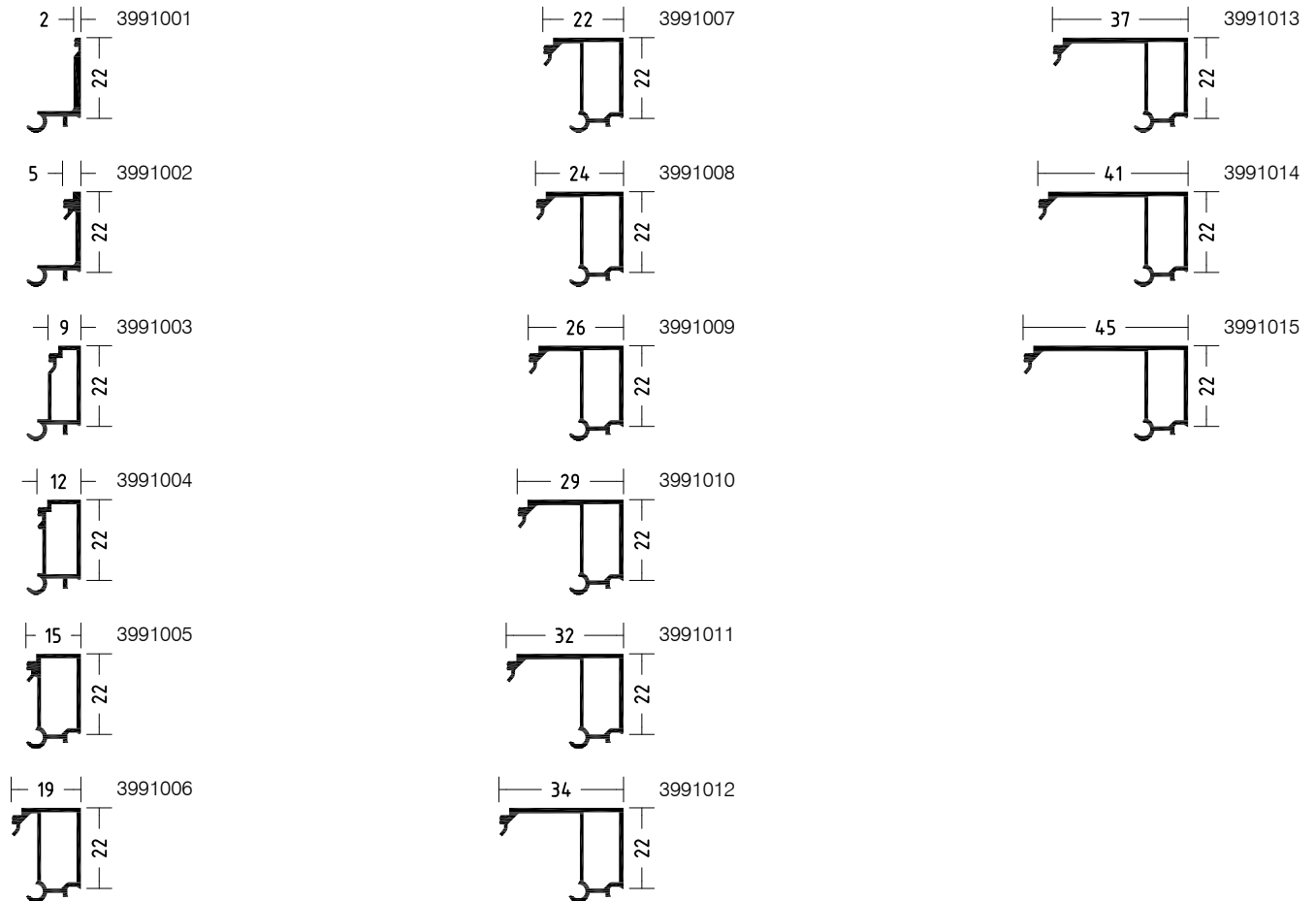

WICSLIDE 160

Profilübersicht
Survey of profiles

Glasleistenprofile Trockenverglasung / Nassverglasung
Glazing bead profiles dry glazing / wet glazing

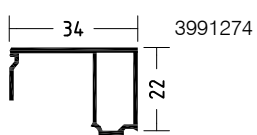
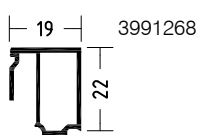
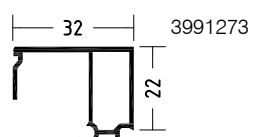
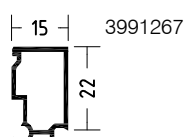
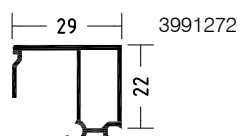
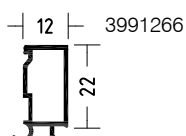
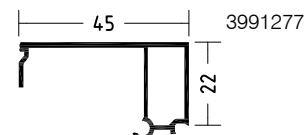
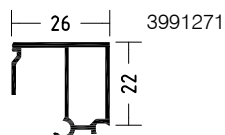
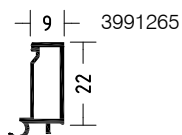
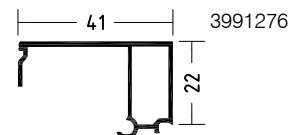
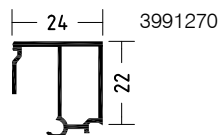
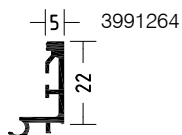
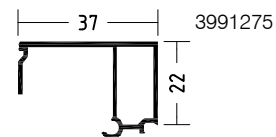
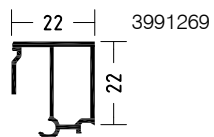
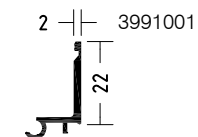

Icon	m	mm	mm	Icon 1			Icon 2			Icon 3			
				4950092	2x4070000	-	-	-	5910051	5940115	5940015	5930014	
☒	1940006	6,5	634	46	4950092	2x4070000	-	-	-	5910051	5940115	5940015	5930014
☒					4950092	2x4070000	-	-	-	5910051	5940115	5940015	5930014

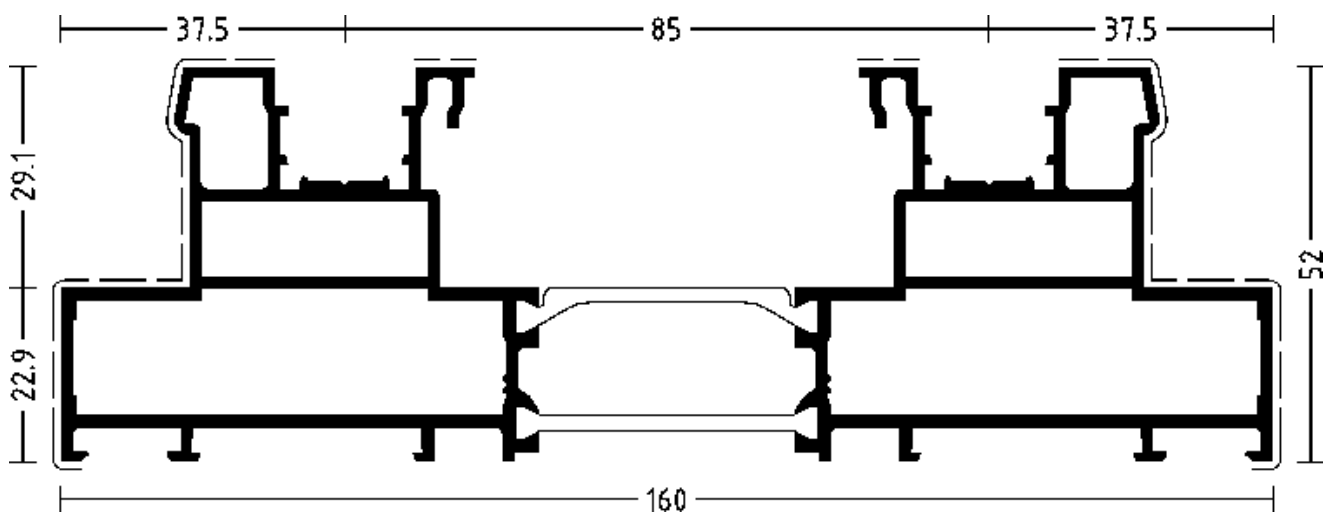

1940006

Stoßverbindung für Stabverlängerung: Verbinder außen 1x 4060388, innen 1x 4060388 Verbindungselement außen 2x 4070000/4070002, innen 2x 4070000/4070002. Bohrschablone und Stanzen siehe Tabelle oben.

Butt joint for bar length extension: Connector outside 1x 4060388, inside 1x 4060388 Connecting element outside 2x 4070000/4070002, inside 2x 4070000/4070002. Drilling template and punching tools see table above.

Symbol	Dimensions			Accessories			Tools						
	m	mm	mm	Part 1	Part 2	Part 3	Tool 1	Tool 2	Tool 3	Tool 4			
☒	1041345	6,5	696	66	4950092	2x4070000	-	-	-	5910051	5940115	5940015	5030075
☒					4950092	2x4070000	-	-	-	5910051	5940115	5940015	5030075

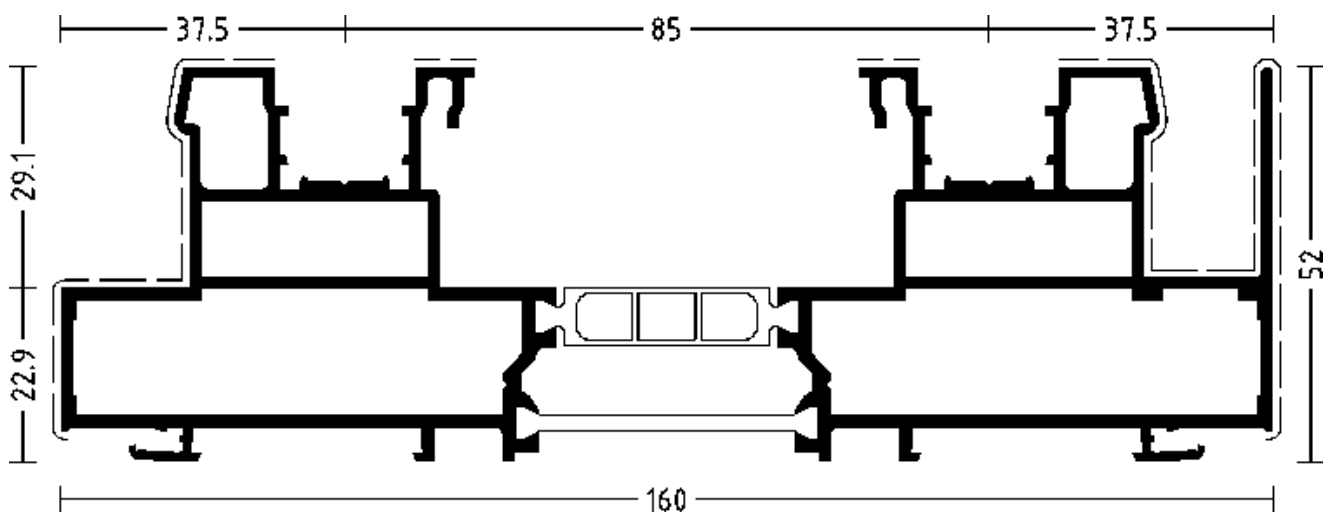

1041345

Stoßverbindung für Stabverlängerung: Verbinder außen 1x 4060388, innen 1x 4060388 Verbindungselement außen 2x 4070000/4070002, innen 2x 4070000/4070002. Bohrschablone und Stanzen siehe Tabelle oben.

Butt joint for bar length extension: Connector outside 1x 4060388, inside 1x 4060388 Connecting element outside 2x 4070000/4070002, inside 2x 4070000/4070002. Drilling template and punching tools see table above.

Symbol	Dimensions			Material			Accessories						
	m	mm	mm	Part 1	Part 2	Part 3	Part 4	Part 5	Part 6	Part 7			
☒	1041346	6,5	750	94	4950092	2x4070000	-	-	-	5910051	5940115	5940015	5030075
☒					4950092	2x4070000	-	-	-	5910051	5940115	5940015	5030075

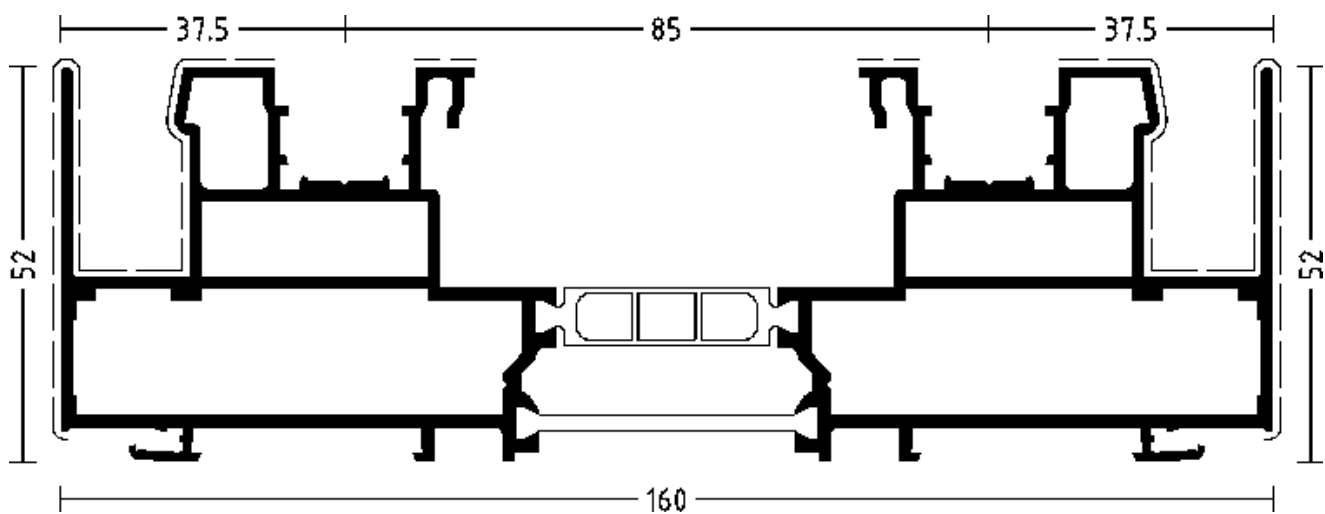

1041346

Stoßverbindung für Stabverlängerung: Verbinder außen 1x 4060388, innen 1x 4060388 Verbindungselement außen 2x 4070000/4070002, innen 2x 4070000/4070002. Bohrschablone und Stanzen siehe Tabelle oben.

Butt joint for bar length extension: Connector outside 1x 4060388, inside 1x 4060388 Connecting element outside 2x 4070000/4070002, inside 2x 4070000/4070002. Drilling template and punching tools see table above.



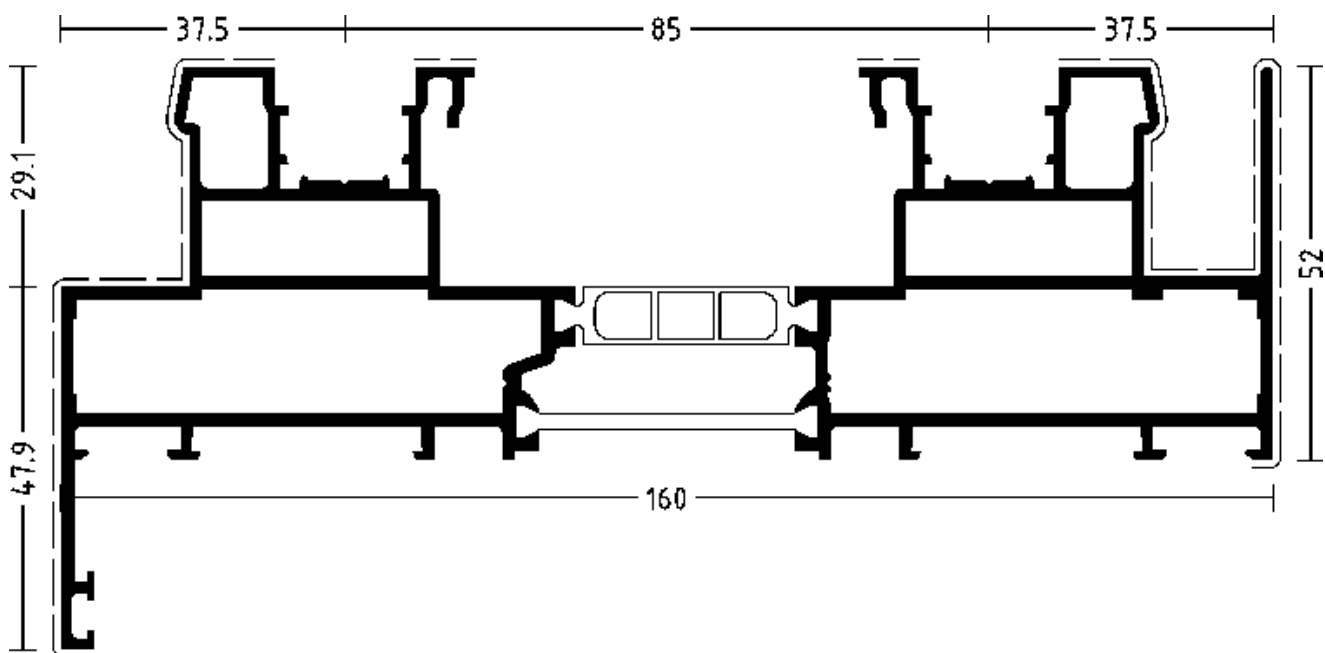











1041347	m	mm	mm	[Icon: L-shaped profile]			[Icon: Pin]			[Icon: Connector]			
				4950092	2x4070000	-	-	-	5910051	5940115	5940015	5930014	
1041347	6,5	759	99	4950092	2x4070000	-	-	-	5910051	5940115	5940015	5930014	
				4950092	2x4070000	-	-	-	5910051	5940115	5940015	5930014	



1041347

Stoßverbindung für Stabverlängerung: Verbinder außen 1x 4060388, innen 1x 4060388 Verbindungselement außen 2x 4070000/4070002, innen 2x 4070000/4070002. Bohrschablone und Stanzen siehe Tabelle oben.





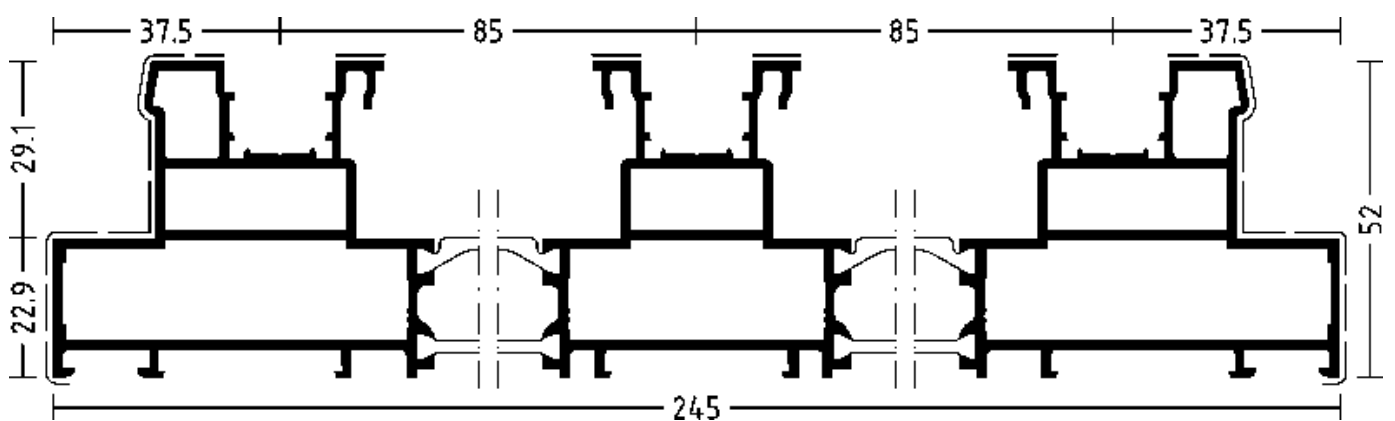





Butt joint for bar length extension: Connector outside 1x 4060388, inside 1x 4060388 Connecting element outside 2x 4070000/4070002, inside 2x 4070000/4070002. Drilling template and punching tools see table above.

													
	m	mm	mm										
 1040001	6,5	927	46	4950092	2x4070000	-	-	-	5910051	5940115	-	5930014	
				4950092	2x4070000	-	-	-	5910051	5940115	-	5930014	



1040001





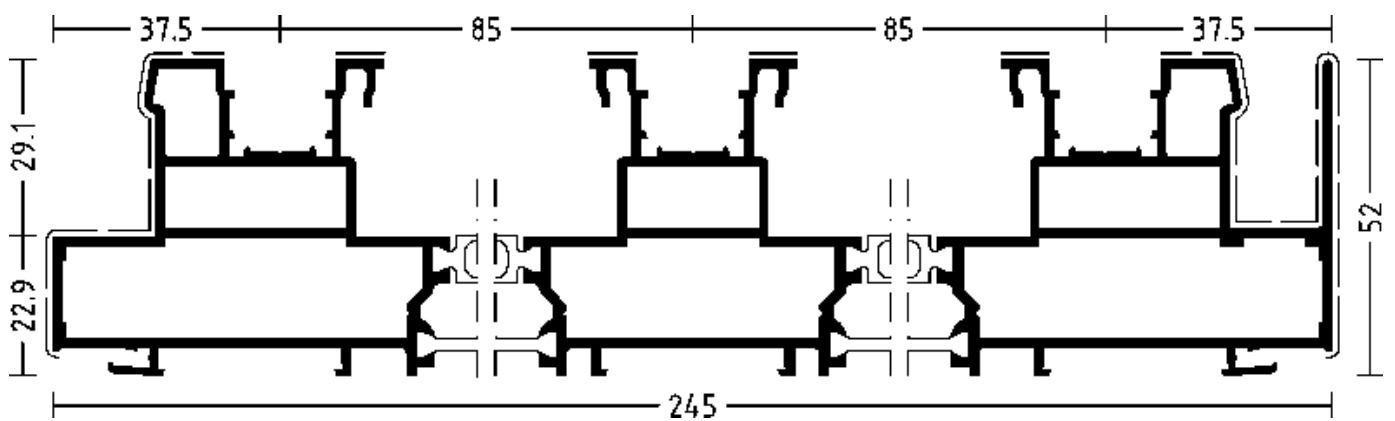









Eckverbindung Mittelschale: Eckwinkel 4950096,
Verbindungselement 2x 4070000/4070002, Bohrschablone 5910057.
Stoßverbindung für Stabverlängerung:
Verbinder außen/innen 2x 4060388, mitte 1x 4060386.
Verbindungselement außen/innen 4x 4070000/4070002,
mitte 2x 4070000/4070002, Bohrschablone 5910057,
Stanzwerkzeug 5940115.
Bohrschablone und Stanzen für außen/innen siehe Tabelle oben.
*Corner connection middle profile shell: corner angle 4950096,
connecting element 2x 4070000/4070002, drill template 5910057.*
*Butt joint for bar length extension:
Connector outside/inside 2x 4060388, middle 1x 4060386.
Connecting element outside/inside 4x 4070000/4070002,
middle 2x 4070000/4070002, drill template 5910057,
Punching tool 5940115.*
Drilling template and punching tools for outside/inside see table above.

	m	mm	mm									
 1040004	6,5	994	66	4950092	2x4070000	-	-	-	5910051	5940115	-	5030075
				4950092	2x4070000	-	-	-	5910051	5940115	-	5030075



1040004

Eckverbindung Mittelschale: Eckwinkel 4950096,
Verbindungselement 2x 4070000/4070002, Bohrschablone 5910057.
Stoßverbindung für Stabverlängerung:
Verbinder außen/innen 2x 4060388, mitte 1x 4060386.
Verbindungselement außen/innen 4x 4070000/4070002,
mitte 2x 4070000/4070002, Bohrschablone 5910057,
Stanzwerkzeug 5940115.
Bohrschablone und Stanzen für außen/innen siehe Tabelle oben.
*Corner connection middle profile shell: corner angle 4950096,
connecting element 2x 4070000/4070002, drill template 5910057.*
*Butt joint for bar length extension:
Connector outside/inside 2x 4060388, middle 1x 4060386.
Connecting element outside/inside 4x 4070000/4070002,
middle 2x 4070000/4070002, drill template 5910057,
Punching tool 5940115.*
Drilling template and punching tools for outside/inside see table above.

												
	m	mm	mm									
 1940019	6,5	622	53	4950008	2x4070000	-	-	-	5910073	5940115	5940001	5930014
				4950092	2x4070000	-	-	-	5910051	5940115	5940001	5930014

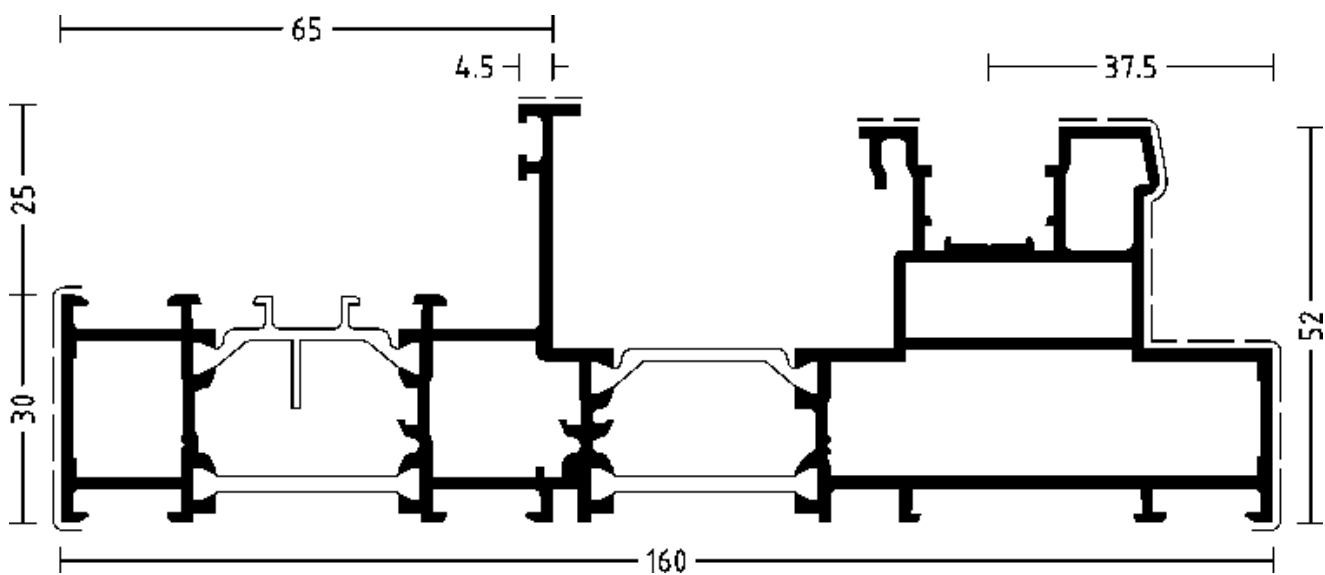

1940019

Eckverbindung Mittenschale: Eckwinkel 4950008,
Verbindungselement 2x 4070000/4070002, Bohrschablone 5910073.
Presstawerkzeug Außen-/Mittenschale: 5930001.
Stoßverbindung für Stabverlängerung:
Verbinder außen 1x 4060377, mitte 1x 4060377, innen 1x 4060388.
Verbindungselement außen 2x 4070000/4070002,
mitte 2x 4070000/4070002, innen 2x 4070000/4070002.
Bohrschablone und Stanzen siehe Tabelle oben.

*Corner connection middle profile shell: corner angle 4950008,
connecting element 2x 4070000/4070002, drill template 5910073.
Crimping tool outer / middle profile shell: 5930001.
Butt joint for bar length extension:
Connector outside 1x 4060377, middle 1x 4060377, inside 1x 4060388.
Connecting element outside 2x 4070000/4070002,
middle 2x 4070000/4070002, inside 2x 4070000/4070002.
Drilling template and punching tools see table above.*

	m	mm	mm										
	1041344	6,5	735	73	4950092	2x4070000	-	-	-	5910051	5940115	5940015	5030075
					4950092	2x4070000	-	-	-	5910051	5940115	5940015	5030075

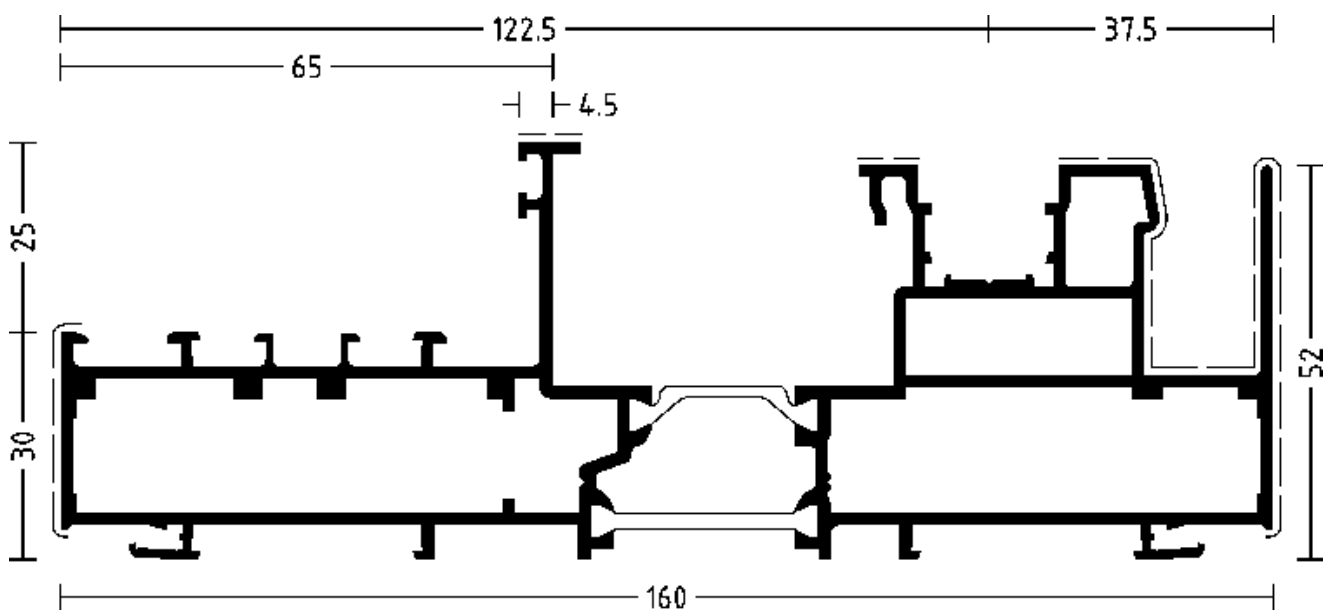

1041344

Stoßverbindung für Stabverlängerung: Verbinder außen 1x 4060388, innen 1x 4060388 Verbindungselement außen 2x 4070000/4070002, innen 2x 4070000/4070002. Bohrschablone und Stanzen siehe Tabelle oben.

Butt joint for bar length extension: Connector outside 1x 4060388, inside 1x 4060388 Connecting element outside 2x 4070000/4070002, inside 2x 4070000/4070002. Drilling template and punching tools see table above.

Symbol	Dimensions			Corner connection inner shell		Corner connection middle shell			Corner connection outer shell				
	m	mm	mm	Part	Part	Part	Part	Part	Part	Part	Part	Part	
☒	1040002	6,5	915	53	4950008	2x4070000	-	-	-	5910073	5940115	-	5930014
☒					4950092	2x4070000	-	-	-	5910051	5940115	-	5930014

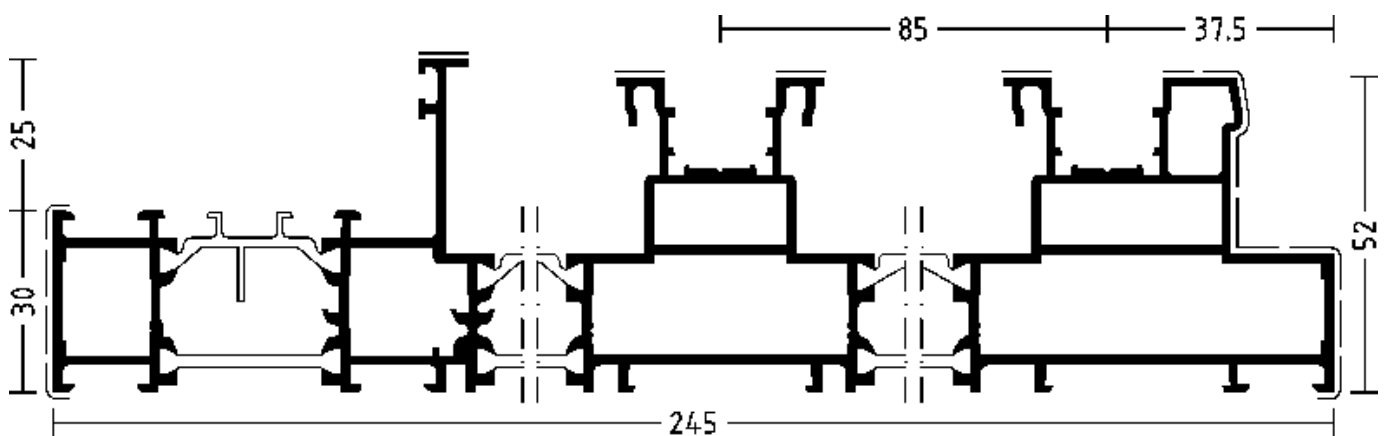















1040002

Eckverbindung innere Außenschale: Eckwinkel 4950008, Verbindungselement 2x 4070000/4070002, Bohrschablone 5910073.
 Eckverbindung Mittelschale: Eckwinkel 4950096, Verbindungselement 2x 4070000/4070002, Bohrschablone 5910057, Stanzwerkzeug 5940115.
 Presstwerkzeug Außenschale: 5930001.
 Stoßverbindung für Stabverlängerung:
 Verbinder außen 2x 4060377, mitte 1x 4060386, innen 1x 4060388.
 Verbindungselement außen 4x 4070000/4070002, mitte 2x 4070000/4070002, innen 2x 4070000/4070002.
 Bohrschablone und Stanzen siehe Tabelle oben.
Corner connection inner outer profile shell: corner angle 4950008, connecting element 2x 4070000/4070002, drill template 5910073.
Corner connection middle profile shell: corner angle 4950096, connecting element 2x 4070000/4070002, drill template 5910057, Punching tool 5940115.
Crimping tool outer / outer profile shell: 5930001.
Butt joint for bar length extension:
 Connector outside 2x 4060377, middle 1x 4060386, inside 1x 4060388.
 Connecting element outside 4x 4070000/4070002, middle 2x 4070000/4070002, inside 2x 4070000/4070002.
 Drilling template and punching tools see table above.

WICSLIDE 160





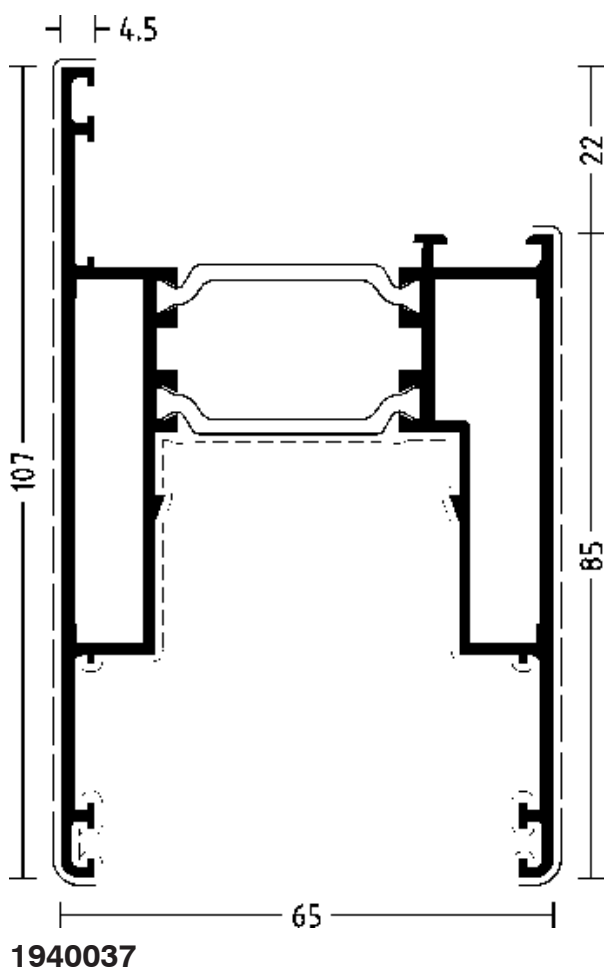









Flügelprofile Sash profiles

	 m	 mm	 mm									
 1940037	6,5	494	192	4950095	2x4070000	-	-	-	5910041	5940113	5940014	5930013
				4950099	2x4070000	-	-	-	5910041	5940113	5940014	5930013



WICSLIDE 160

Kämpfer, Sprossenprofile
Transom, glazing bar profiles

												
	m	mm	mm									
 1916203	6,5	359	110	4950008	2x4070000	1x4960004	1x4070000	1x4070030	5910073	5940101	5940001	5930001
				4950008	2x4070000	1x4960004	1x4070000	1x4070030	5910073	5940101	5940001	5930001

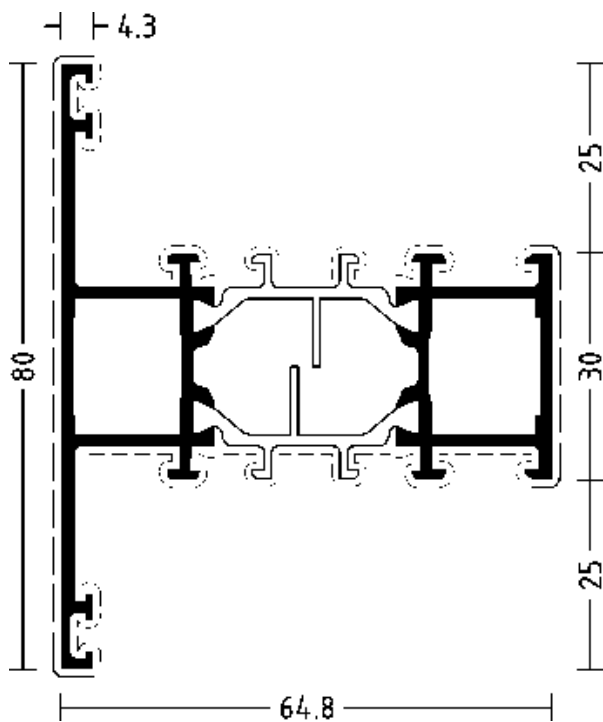















1916203

Gelenkeckwinkel und Gelenkverbinder siehe Zusatzartikel. Stoßverbindungen mit Tür-Flügelprofilen WICSTYLE 65 Verbinder 4960054 (außen). Stoßverbindungen mit Flügelprofilen WICSLIDE 160 Verbinder 4960026 (außen).

See additional articles for hinged corner angles and hinged connectors. Butt joint connections with WICSTYLE 65 door leaf profiles, connector 4960054 (outside). Butt joint connections with WICSLIDE 160 sash profiles, connector 4960026 (outside).

WICSLIDE 160

Pfostenprofile
Mullion profiles

												
	m	mm	mm									
 1040010	6,5	443	173	-	-	1x4960009	1x4070000	2x4070030	5910073	5940101	5940001	-
				-	-	2x4960002	2x4070000	-	5910073	5940101	5940001	-
1940041	6,5	471	197	-	-	1x4960009	1x4070000	2x4070030	5910073	5940101	5940001	-
				-	-	1x4960009	2x4070000	2x4070030	5910073	5940101	5940001	-

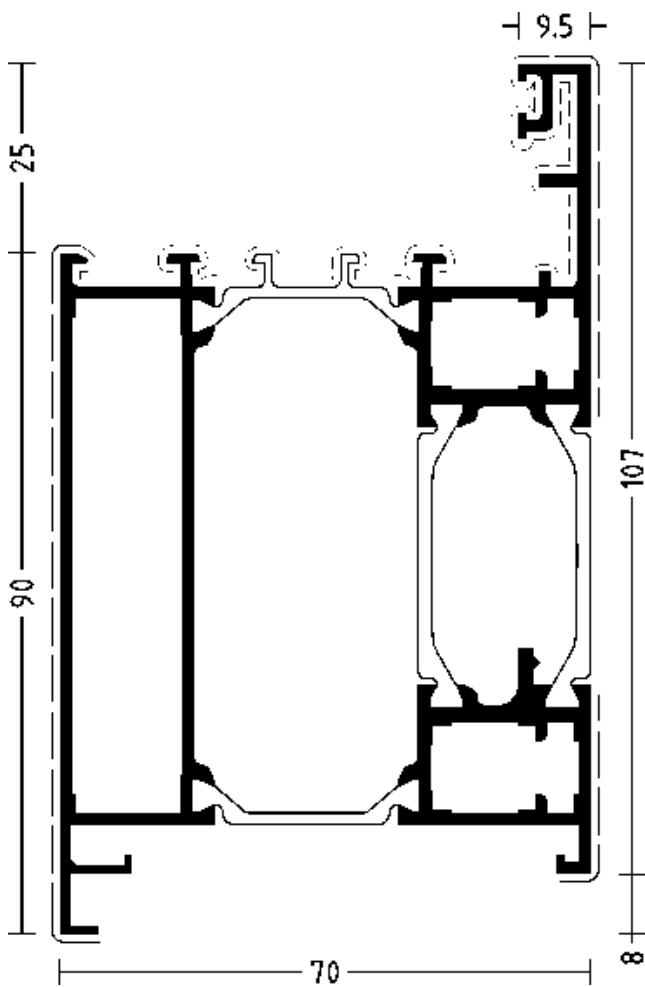

1040010

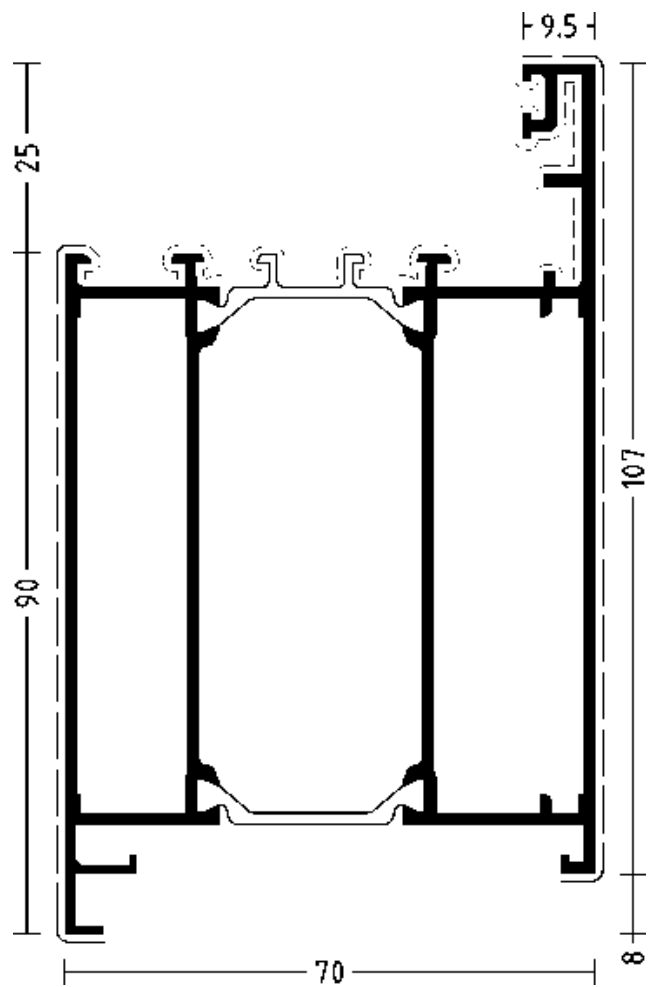

hochwärmedämmend
high thermal insulation



1940041

WICSLIDE 160

Kupplungsprofile
Coupling profiles

	 m	 mm	 mm
1041331	6,5	491	158
1041339	6,5	471	148

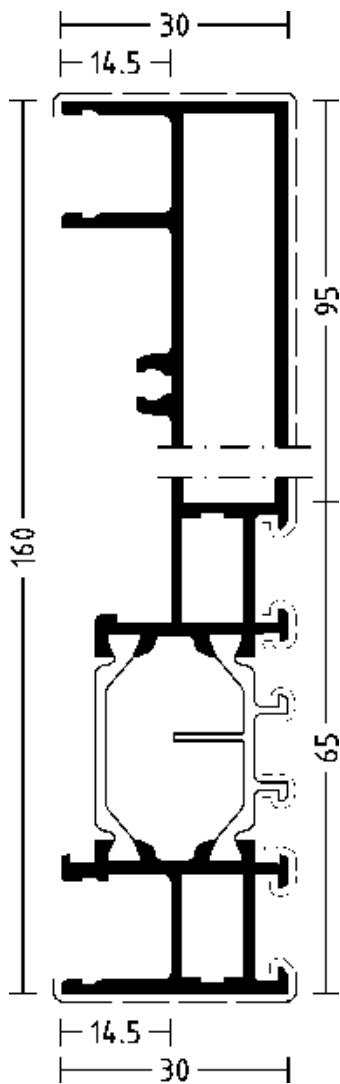

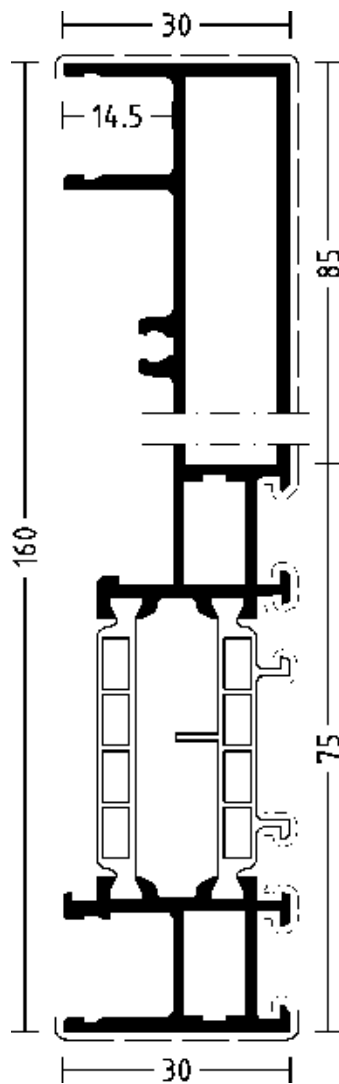

1041331



1041339

WICSLIDE 160

Abdeckprofile
Cover profiles

	 m	 mm	 mm
3041228	6,5	310	97
3940004	6,5	307	94
3041306	6,5	302	86
3041305	6,5	298	86

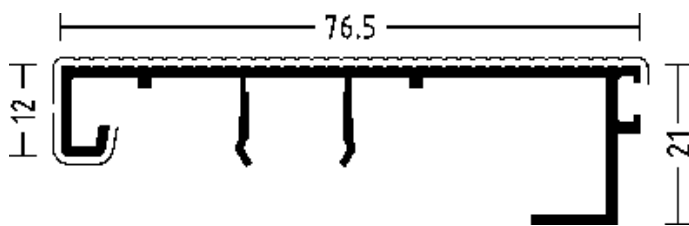

3041228

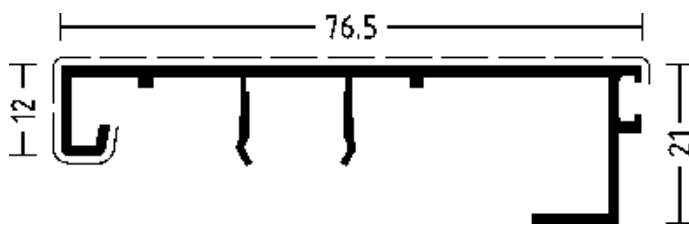

3940004

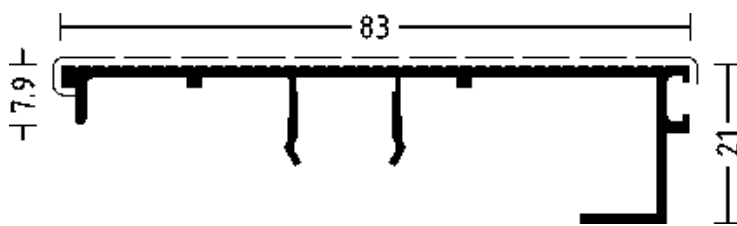

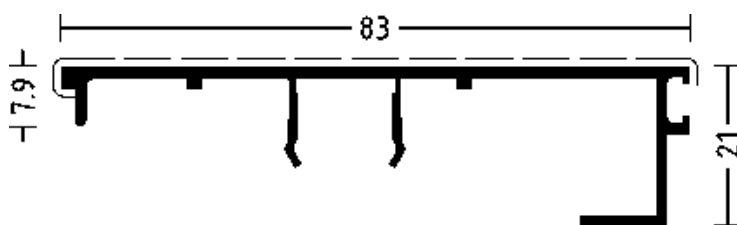

3041306



3041305

WICSLIDE 160

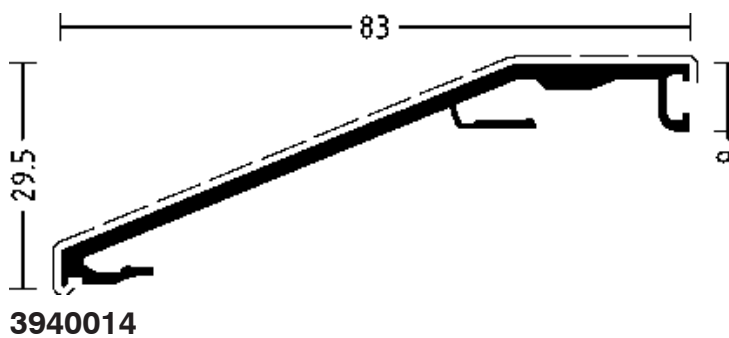
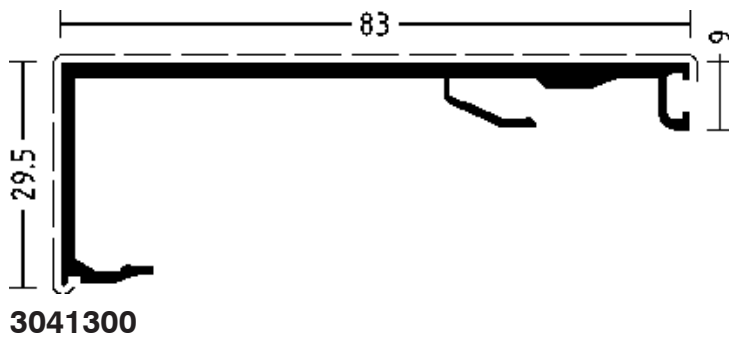
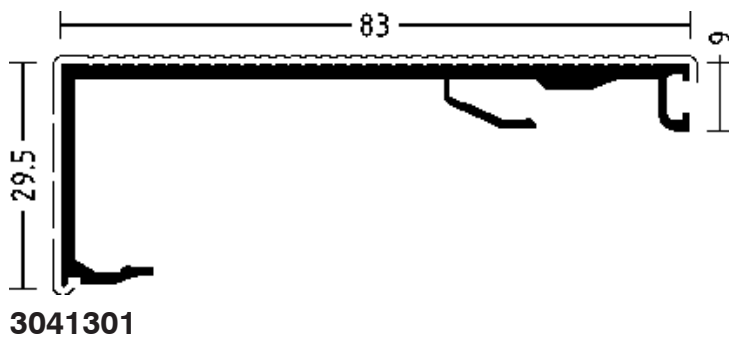

Abdeckprofile
Cover profiles

	 m	 mm	 mm
3041301	6,5	301	30
3041300	6,5	298	113
3940014	6,5	254	88



WICSLIDE 160

Abdeckprofile
Cover profiles

	 m	 mm	 mm
3041314	6,5	252	29
3041315	6,5	250	98
3041312	6,5	352	85
3940019	6,5	98	17
3041321	6,5	164	57

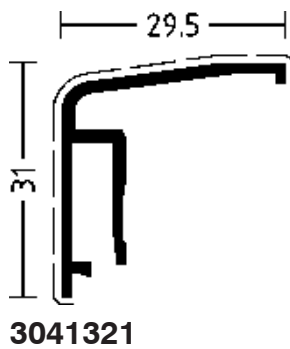
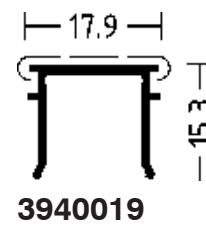
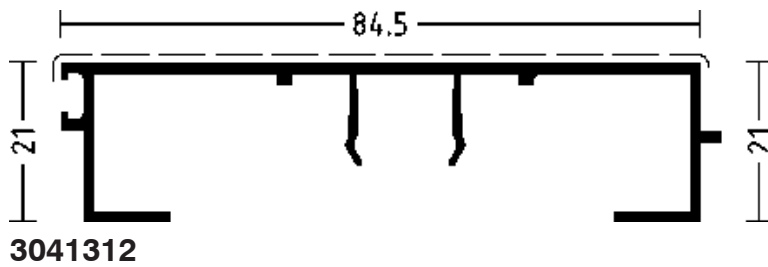
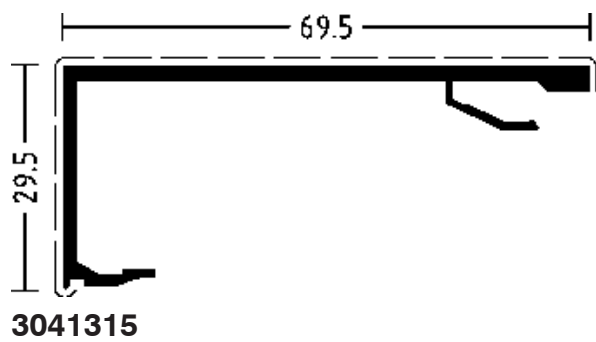
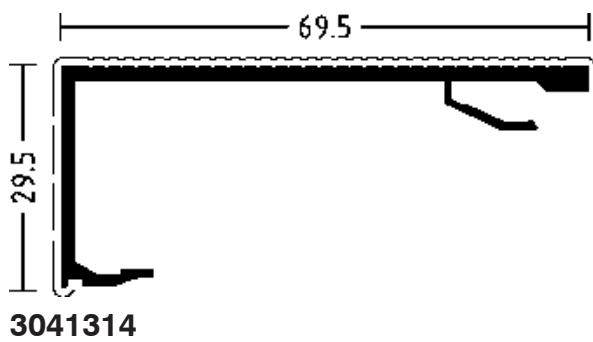

für Entwässerungsöffnungen
for drainage openings

WICSLIDE 160

Konstruktionsschnitt

Construction section

Konstruktionsschnitte Übersicht

Survey of construction sections

Blendrahmen zweibahnig:

Double track frame profile:

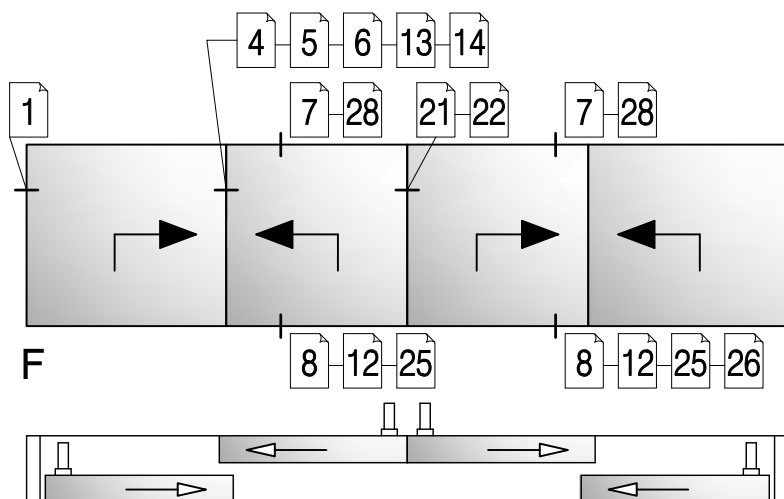
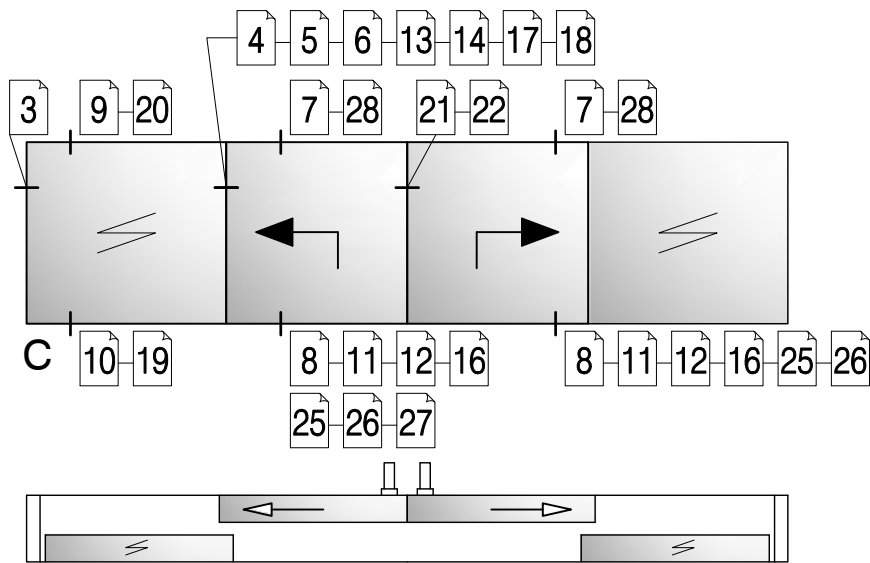
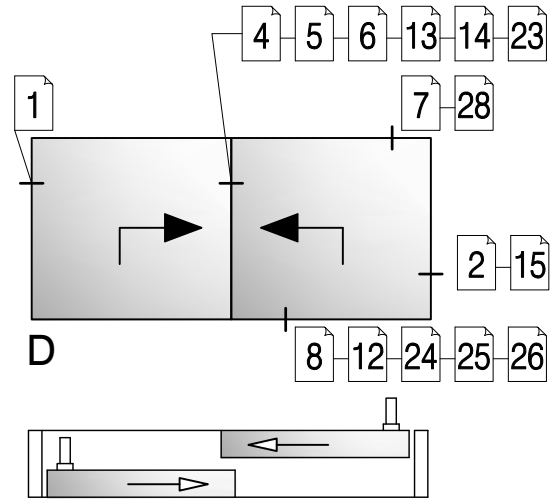
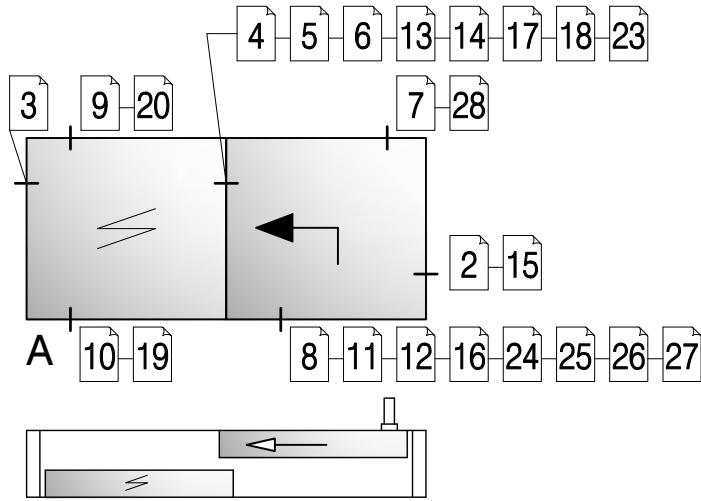

Hinweis / Note:

 Symbol für Hebe-Schiebelemente
Symbol for lifting sliding units

 Festfeld, festgestellter Flügel
Fixed glazing, fixed leaf

 Griffseite
Handle side

 Zweibahnig
Double track

 Dreibahnig
Triple track

WICSLIDE 160

Konstruktionsschnitt
Construction section

Konstruktionsschnitte Übersicht
Survey of construction sections

Blendrahmen zweibahnig:
Double track frame profile:

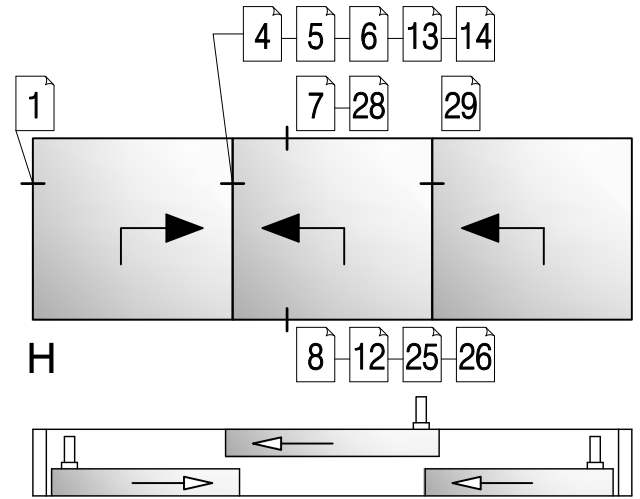
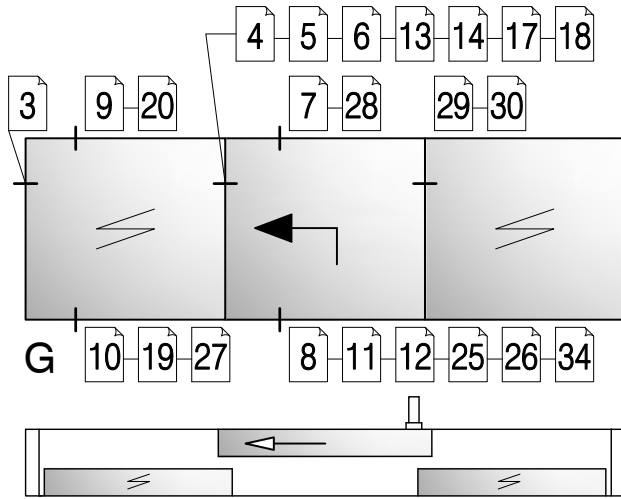

Verbindung zu WICLINE
Connection to WICLINE

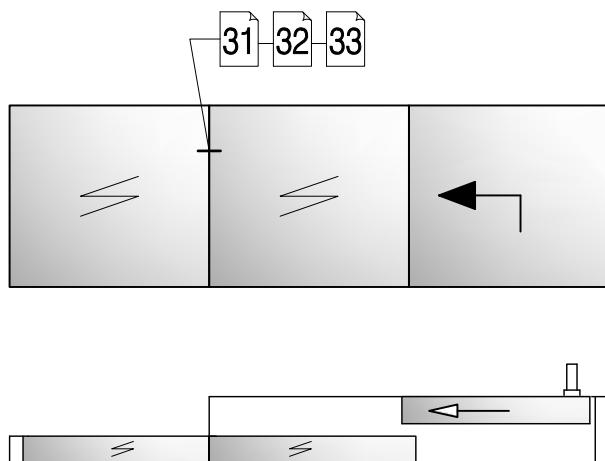

Symbol für Hebe-Schiebeelemente
Symbol for lifting sliding units

≡ Festfeld, festgestellter Flügel
Fixed glazing, fixed leaf

└ Griffseite
Handle side

1 Zweibahnig
Double track

1 Dreibahnig
Triple track

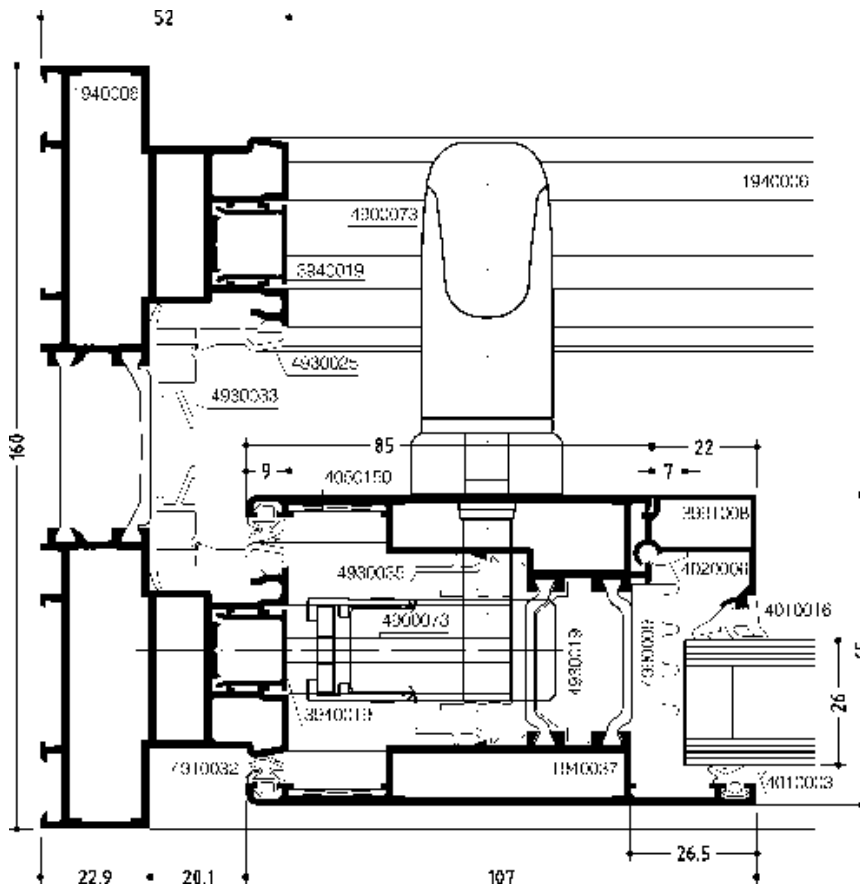

DOC-0000861989

Flügelprofil in
Blendrahmen

*Sash profile in
frame*



DOC-0000861991

Flügelprofil in
Blendrahmen

Sash profile in
frame

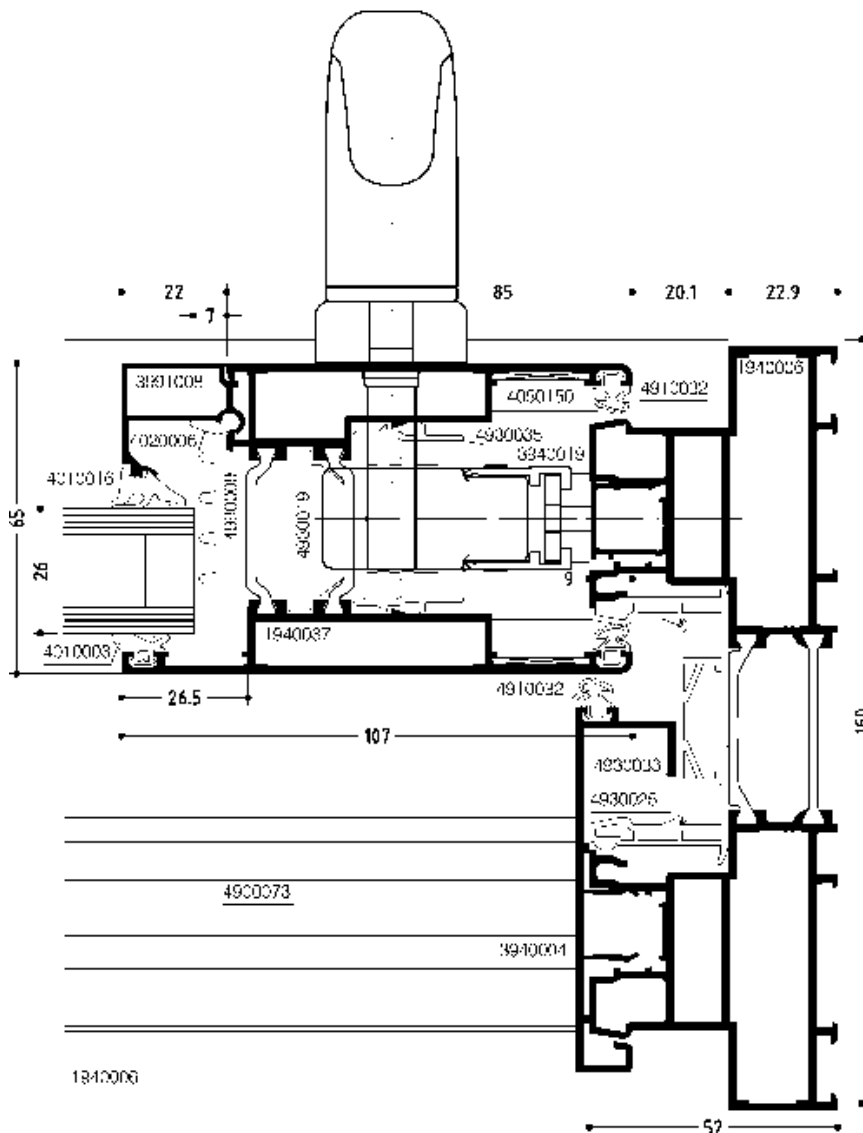

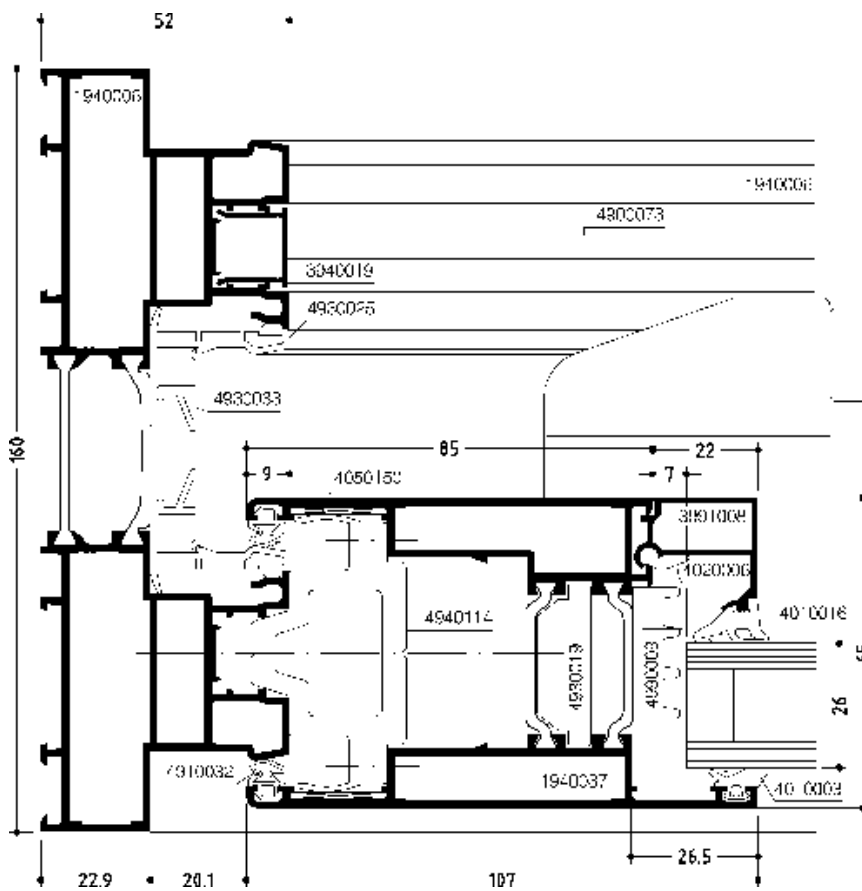

DOC-0000861992

Flügelprofil, fest-
gestellt in Blendrah-
men

*Sash profile fixed in
frame*

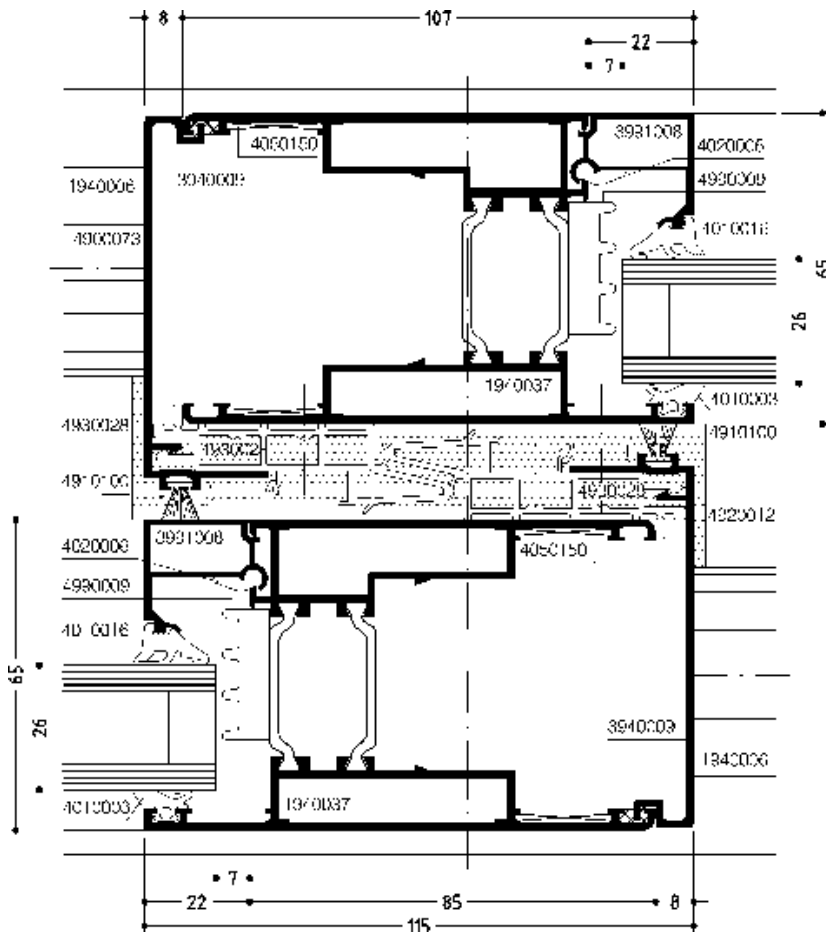

DOC-0000861993

Verhakungszone,
Standard

*Hooking zone,
standard*



DOC-0000861999

Verhakungszone,
Standard, mit
verstärkten Flügel-
aufsatz- profilen

*Hooking zone,
standard, with
reinforced
supplementary
profiles*

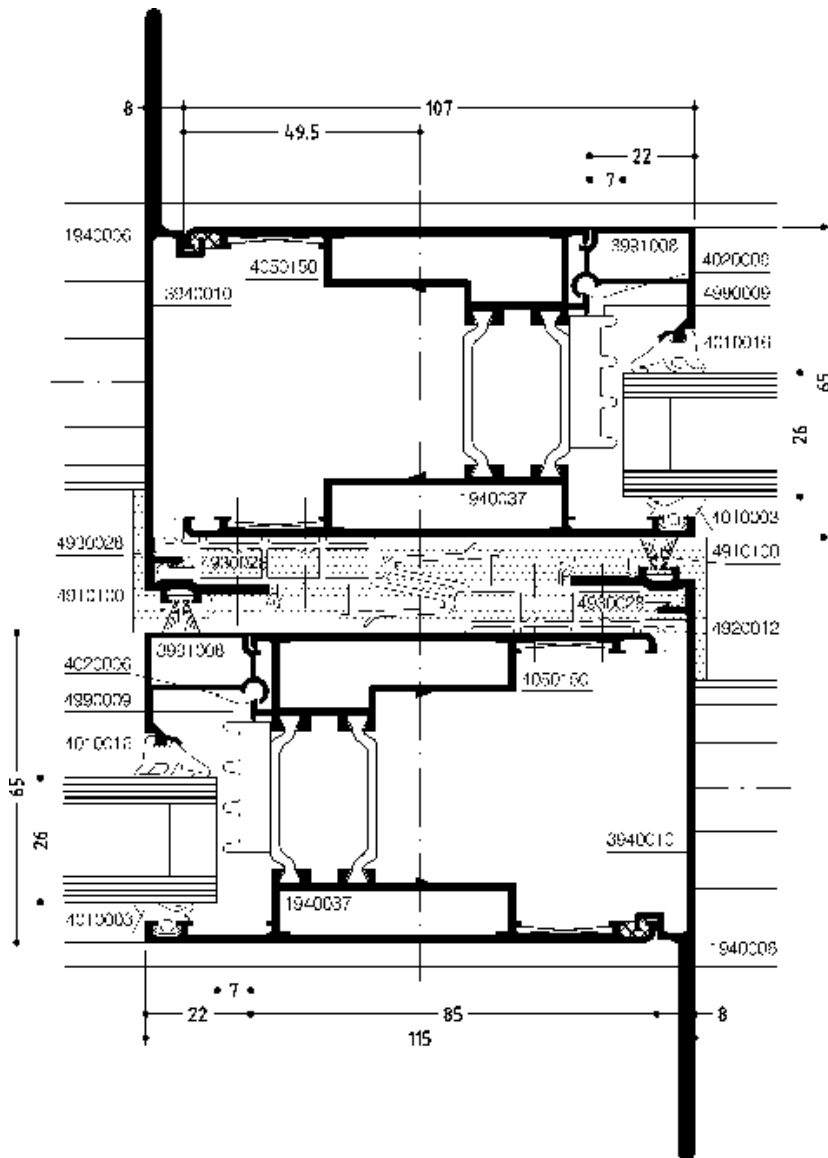



DOC-0000862001

Verhakungszone,
Standard, mit
Verstärkungs-
profilen

*Hooking zone,
standard, with
reinforcement
profiles*

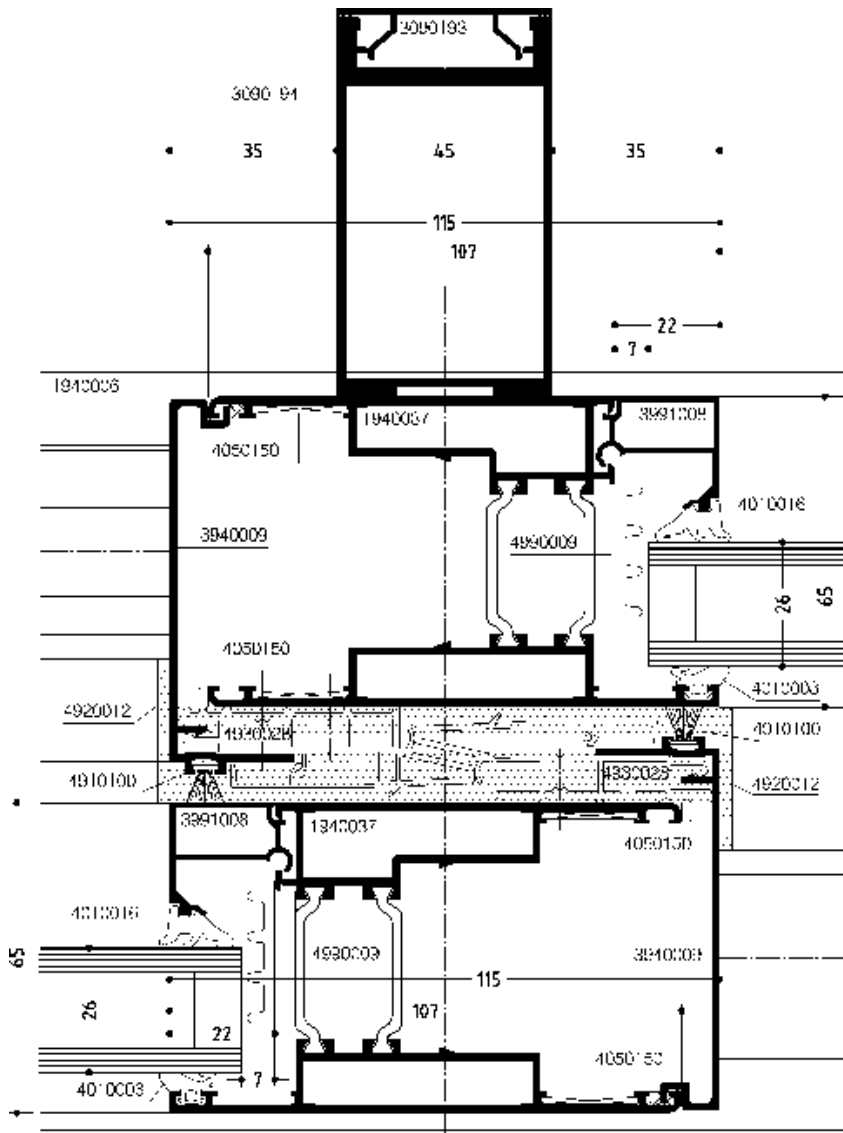

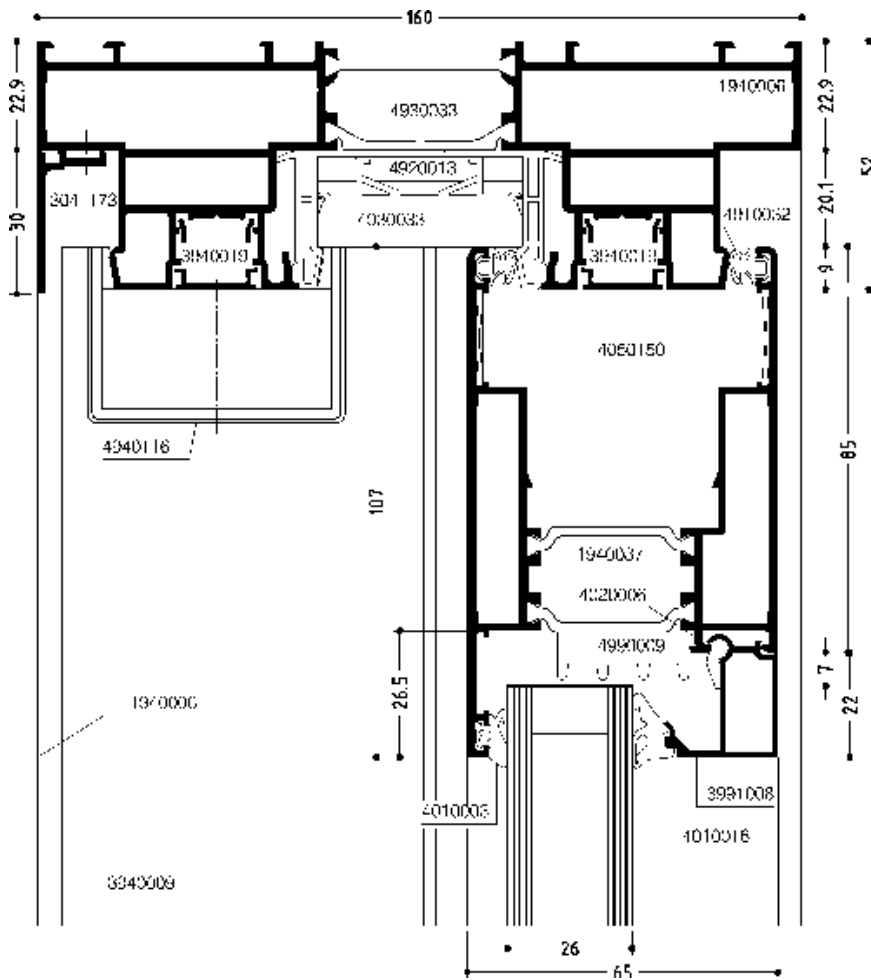

DOC-0000862004

Flügelprofil im
Blendrahmen

*Sash profile in
frame*

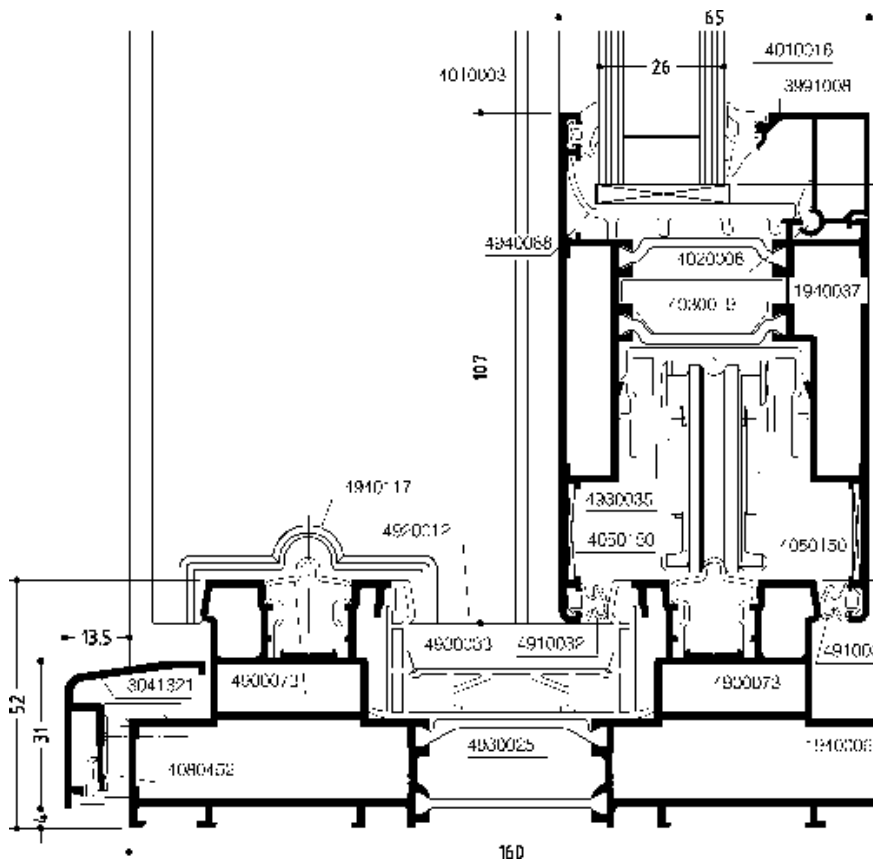

DOC-0000862035

Flügelprofil im
Blendrahmen

Sash profile in
frame

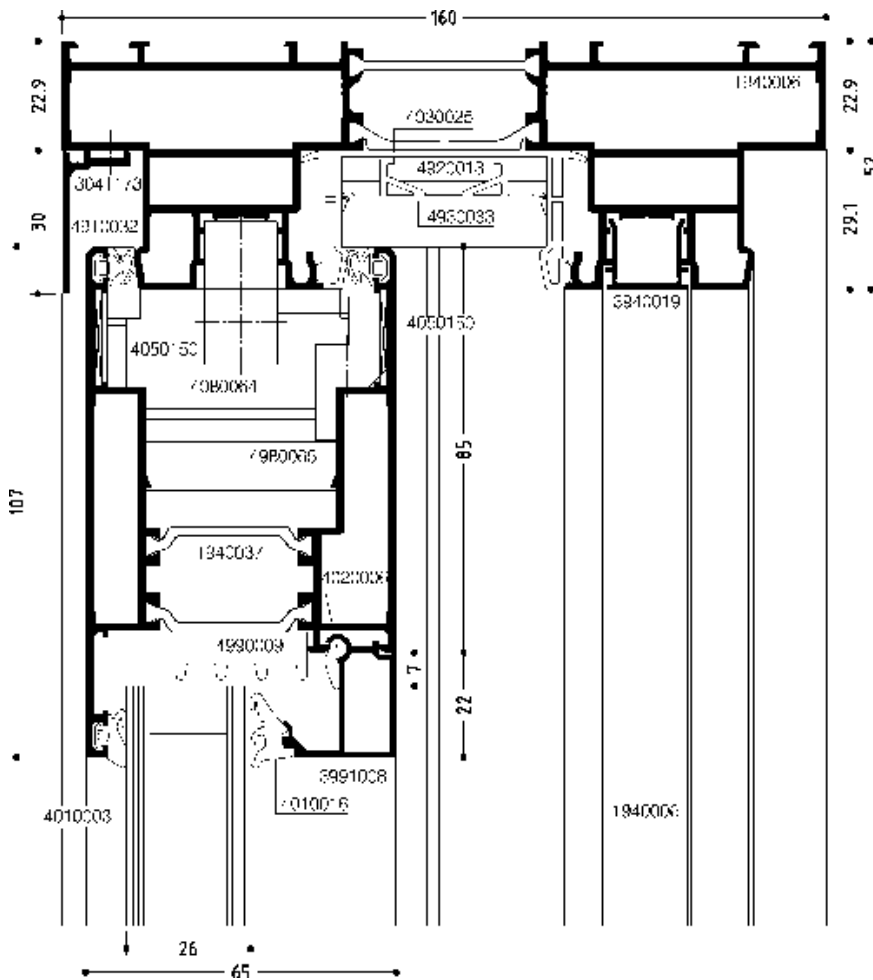

DOC-0000862040

Flügelprofil, fest-
stellt in Blendrah-
men

*Sash profile, fixed
in frame*

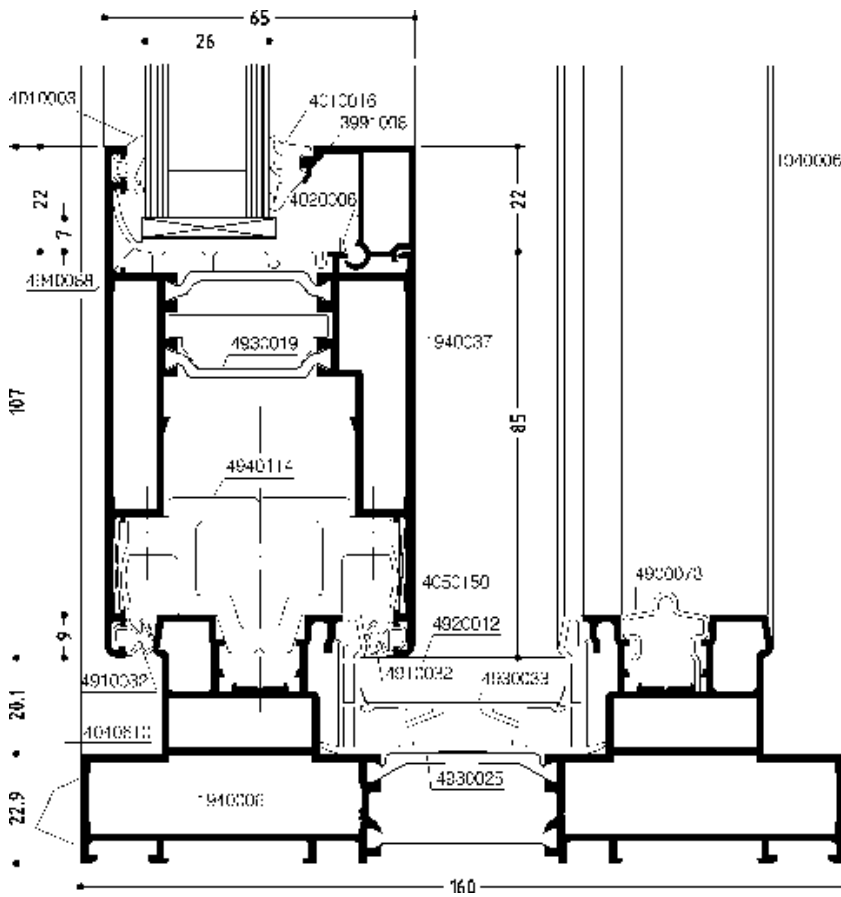

DOC-0000862043

Flügelprofil, fest-
gestellt in Blendrah-
men

*Sash profile, fixed
in frame*

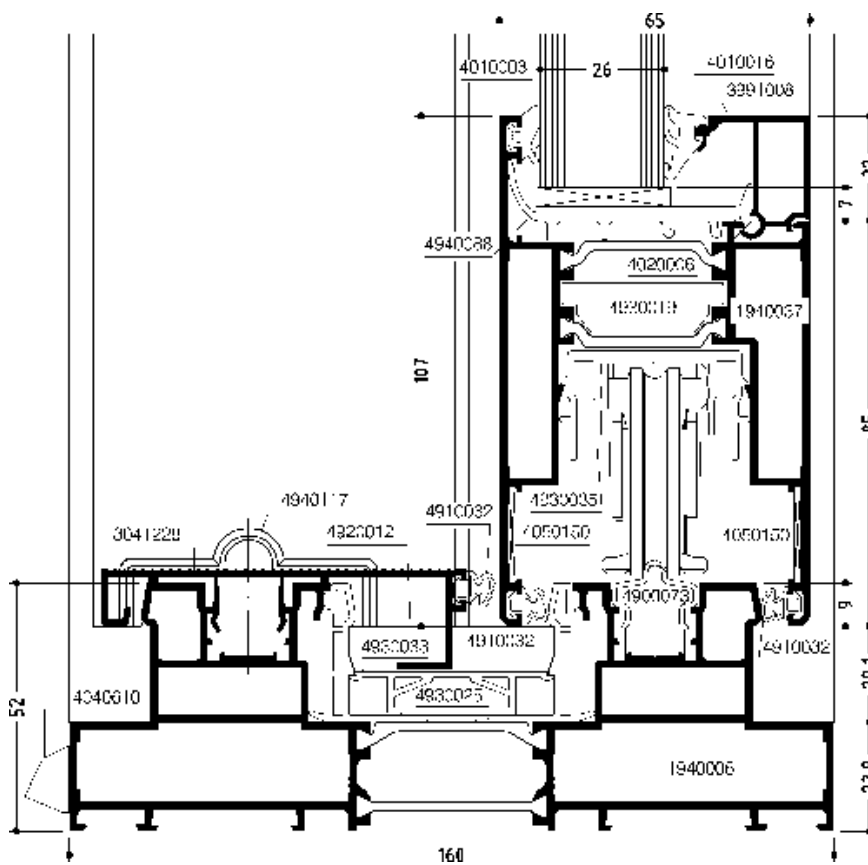

11

DOC-0000862566

Flügelprofil im
Blendrahmen
mit Abdeckprofil
3041228

*Sash profile in
frame with cover
profile 3041228*

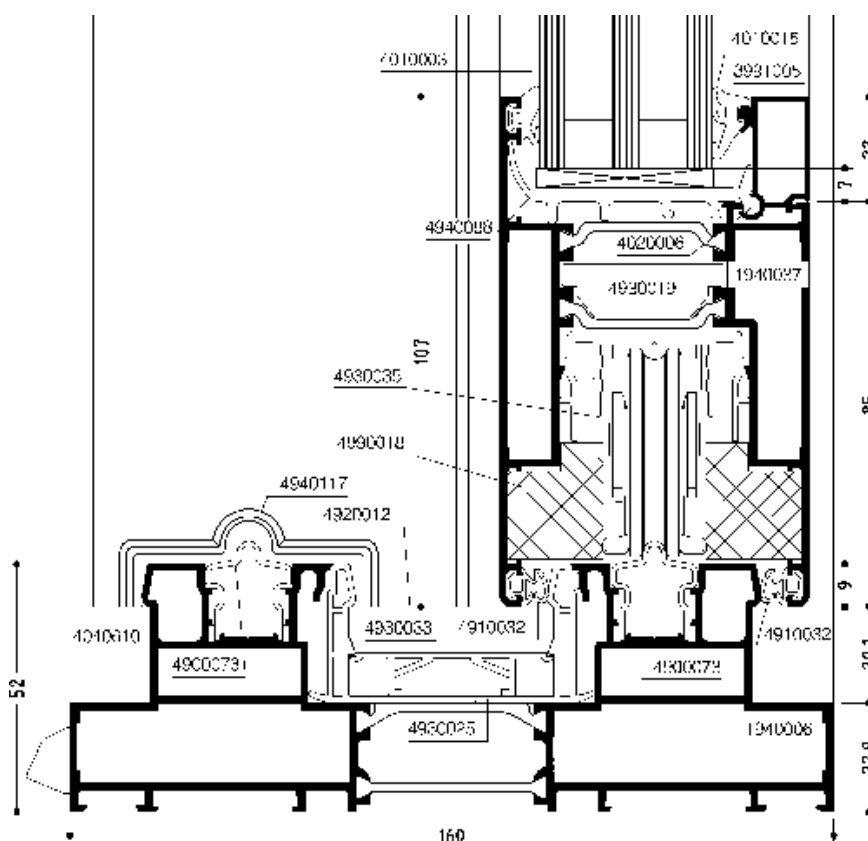

12

DOC-0000900404

Hochwärme-
dämmend, Flügel-
profil im Blendra-
hmen

*High thermal
insulation, sash
profile in frame*

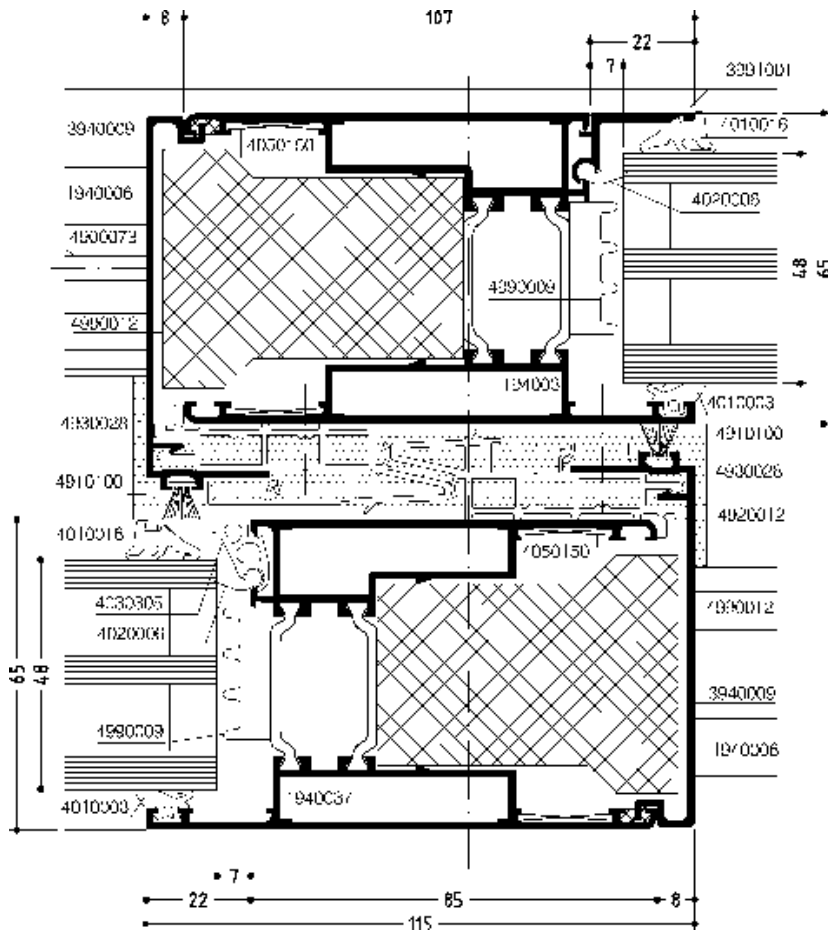

DOC-0000900467

Hochwärme-
dämmend, Verha-
kungszone mit
4030305

*High thermal
insulation, hooking
zone with 4030305*

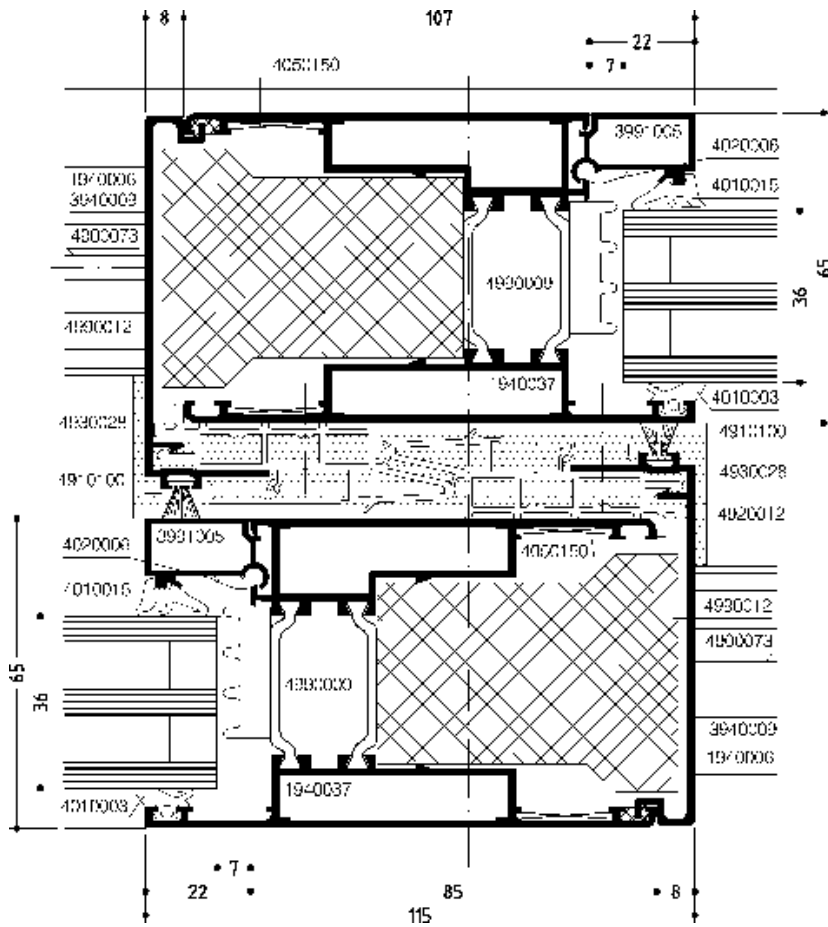

DOC-0000900344

Hochwärme-
dämmend, Verha-
kungszone

*High thermal
insulation, hooking
zone*



DOC-0000900528

Hochwärme-
dämmend, Flügel-
profil in Blendrah-
men

*High insulated,
sash profile in
frame*

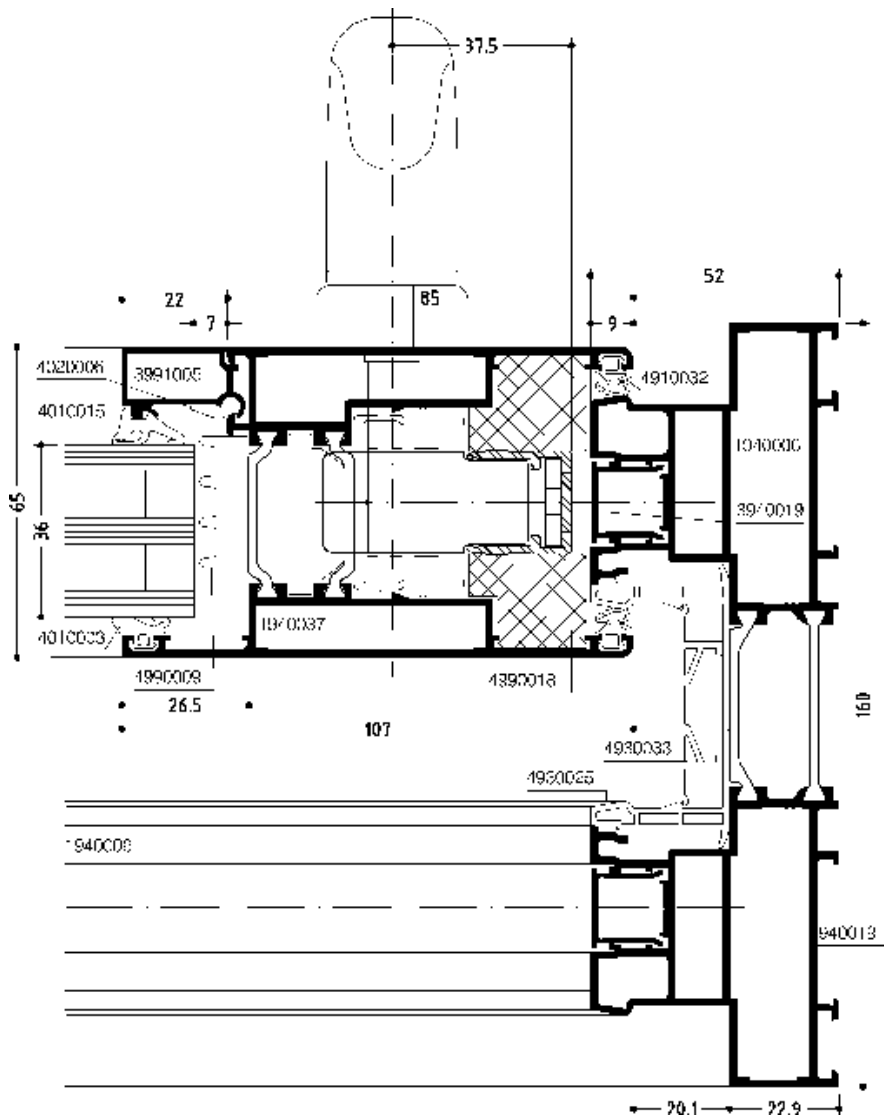

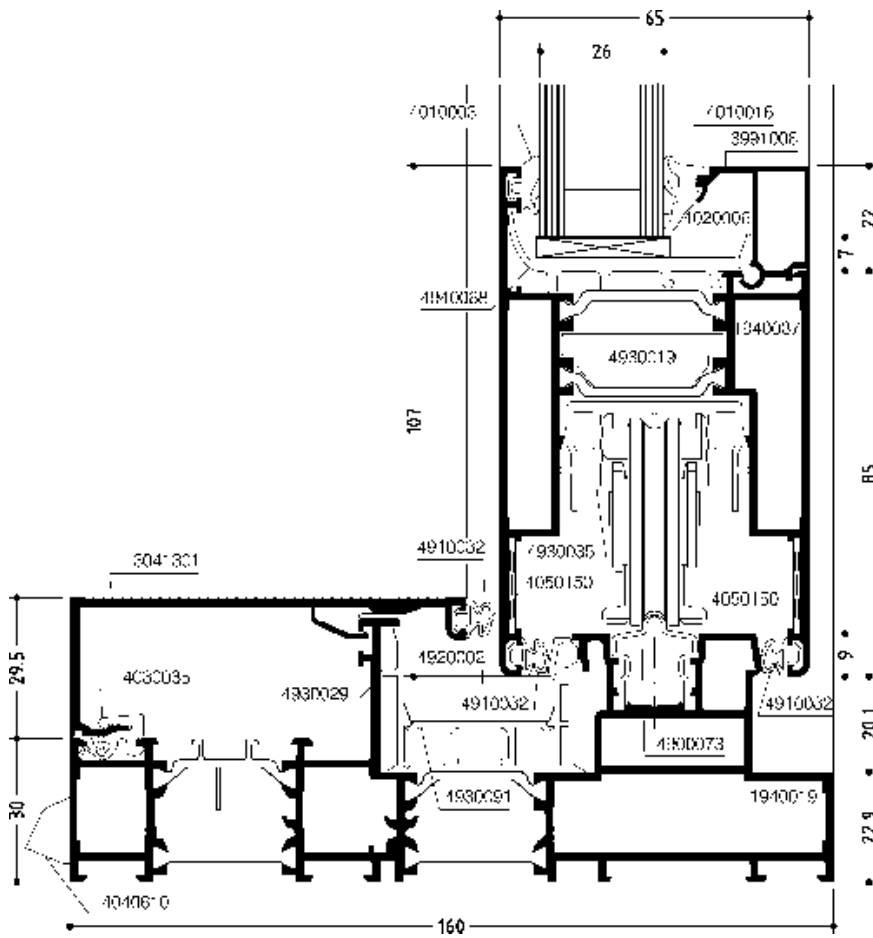

DOC-0000885783

Flügelprofil im
Blendrahmen
mit Abdeckprofil
3041301

*Sash profile in
frame with cover
profile 3041301*

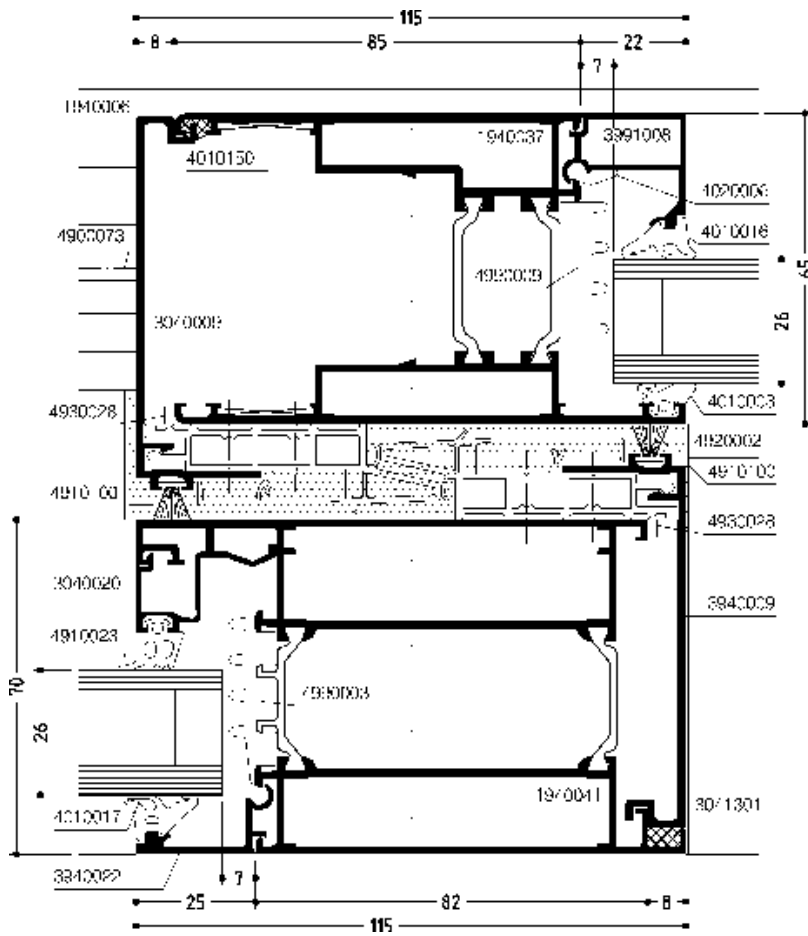

DOC-0000885704

Verhakungszone,
Festverglasung
*Hooking zone, fixed
glazing*

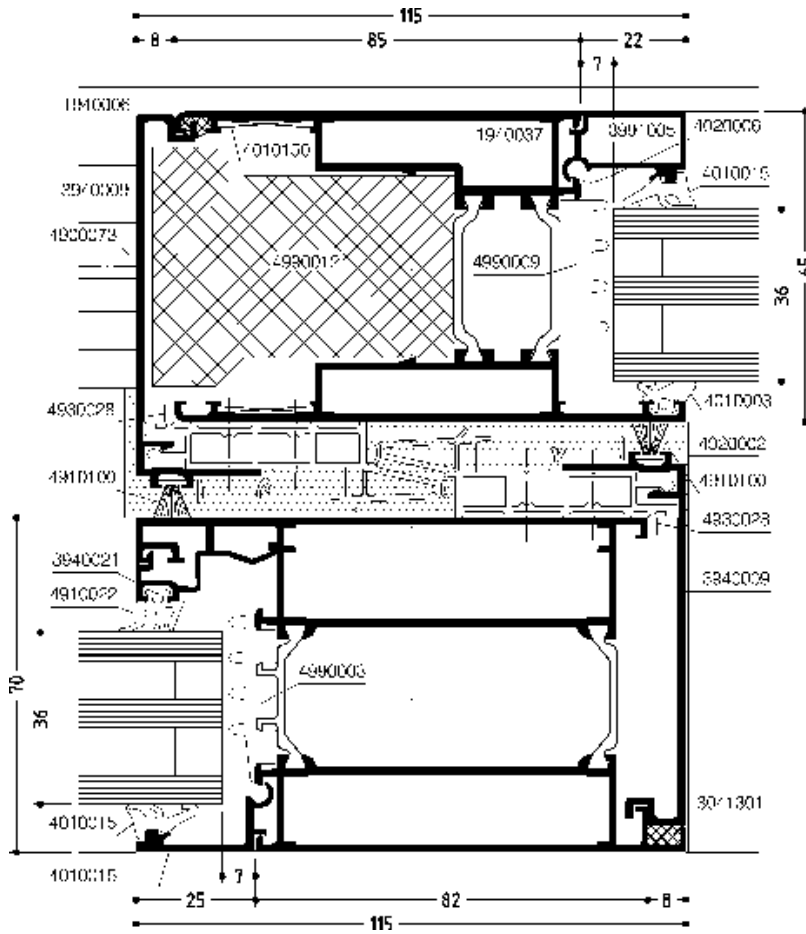

18

DOC-0000918456

Hochwärme-
dämmend, Festver-
glasung

*High thermal
insulation, fixed
glazing*

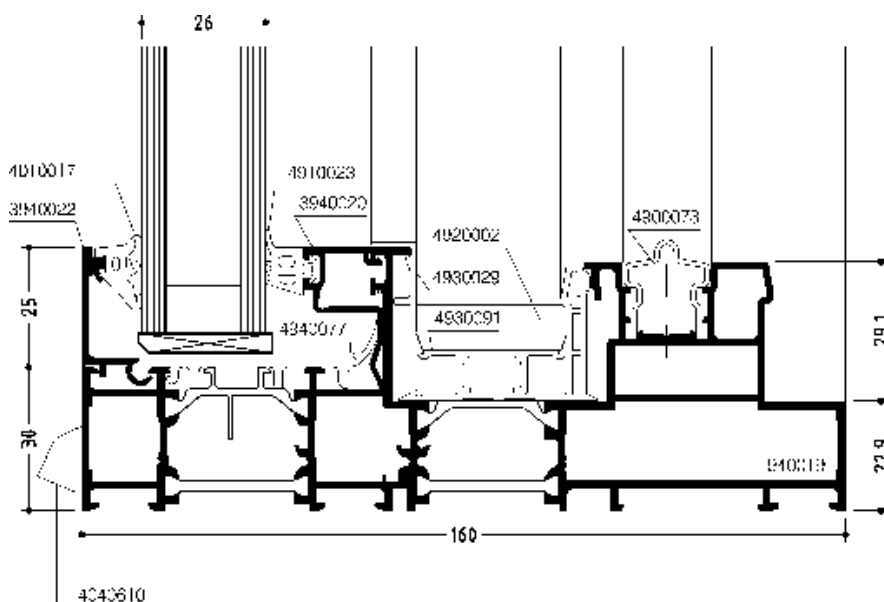

19

DOC-0000886242

Festverglasung
Fixed glazing

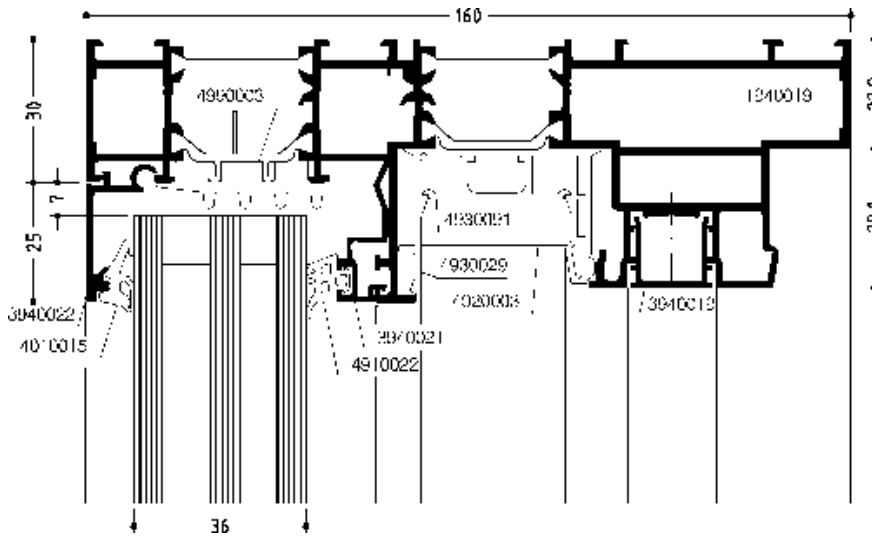

20

DOC-0000918546

Hochwärme-
dämmung, Festver-
glasung

*High thermal
insulation, fixed
glazing*

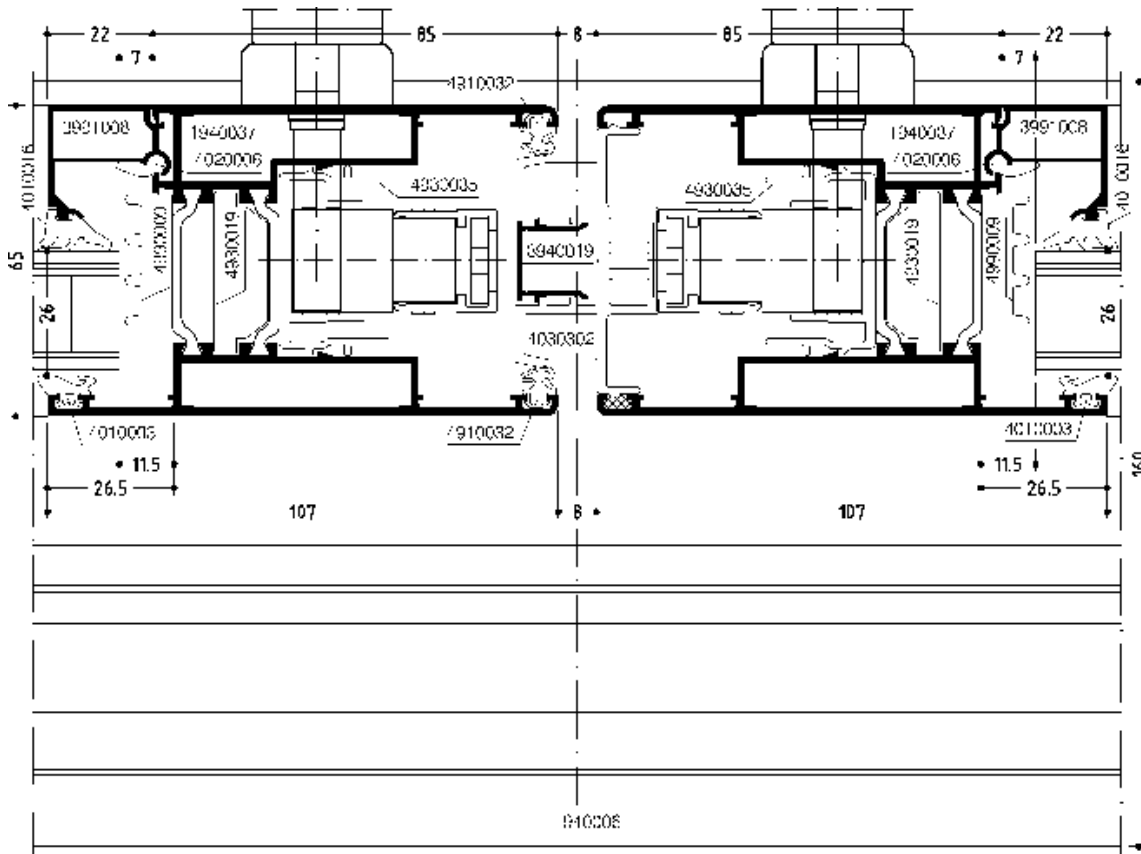

21

DOC-0000918552

Stulpflügel
Double casement

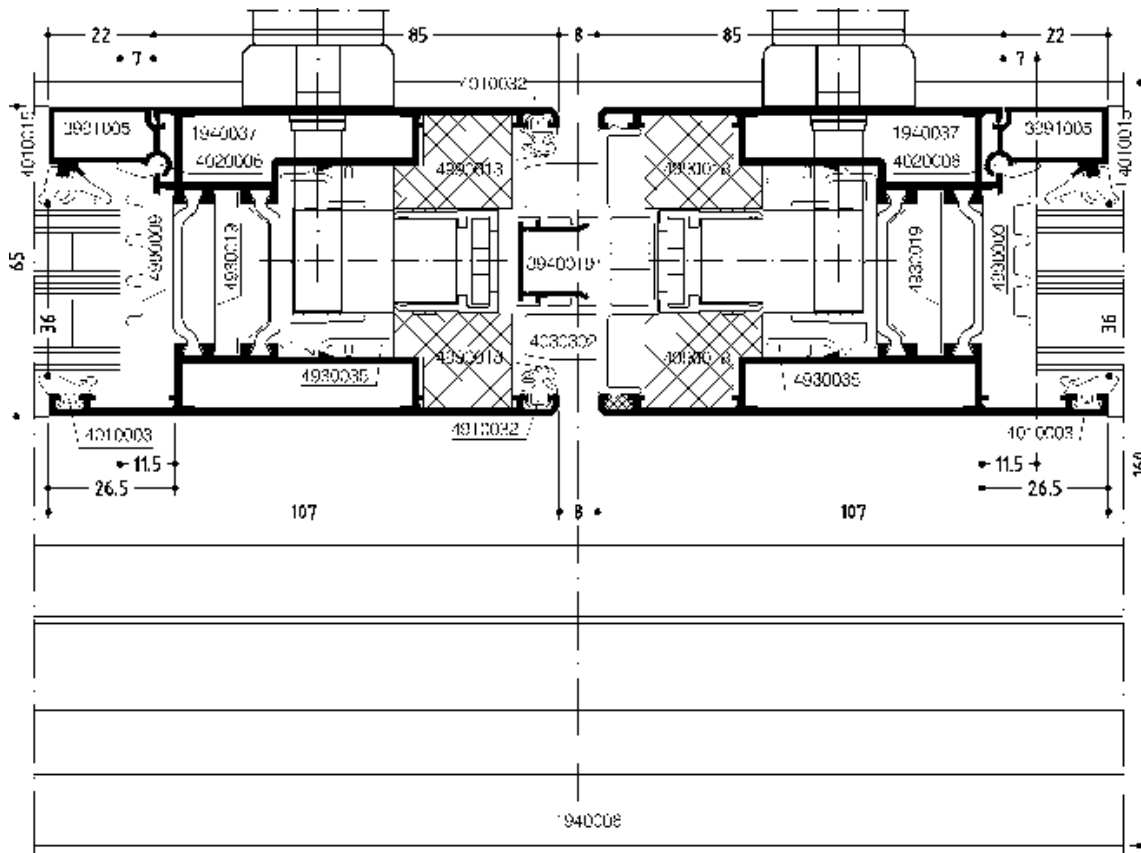

22

DOC-0000918629

Hochwärme-
dämmend, Stul-
pflügel

*High thermal
insulation, double
casement*

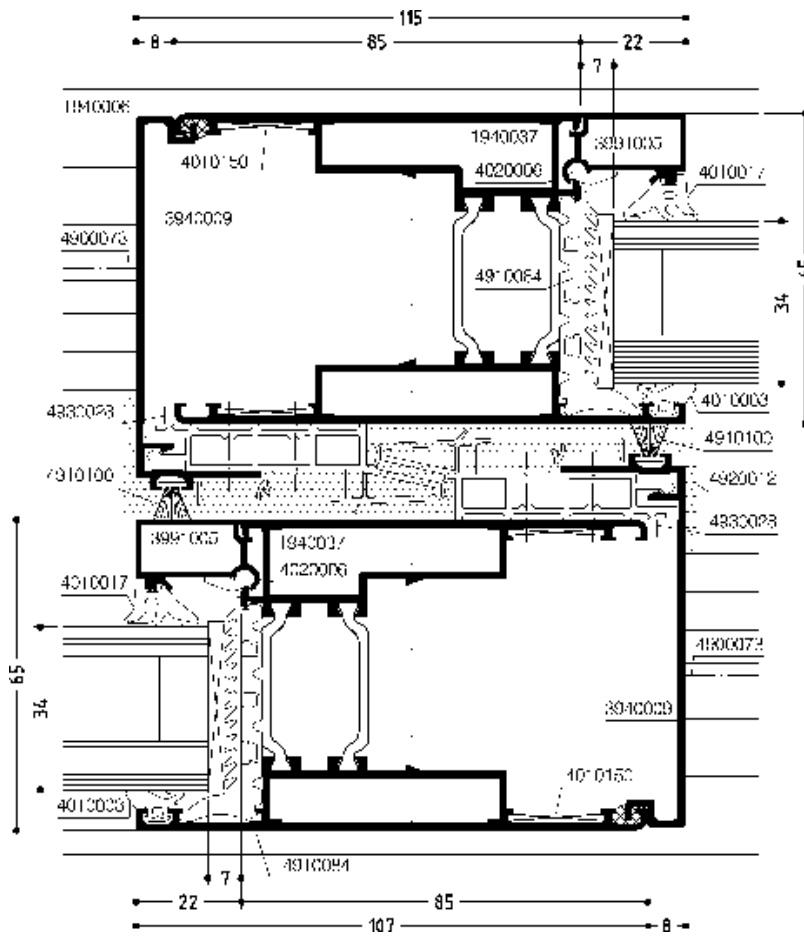

23



DOC-0000883560

Verhakungszone,
einbruchhemmend
*Hooking zone,
burglar resistant*

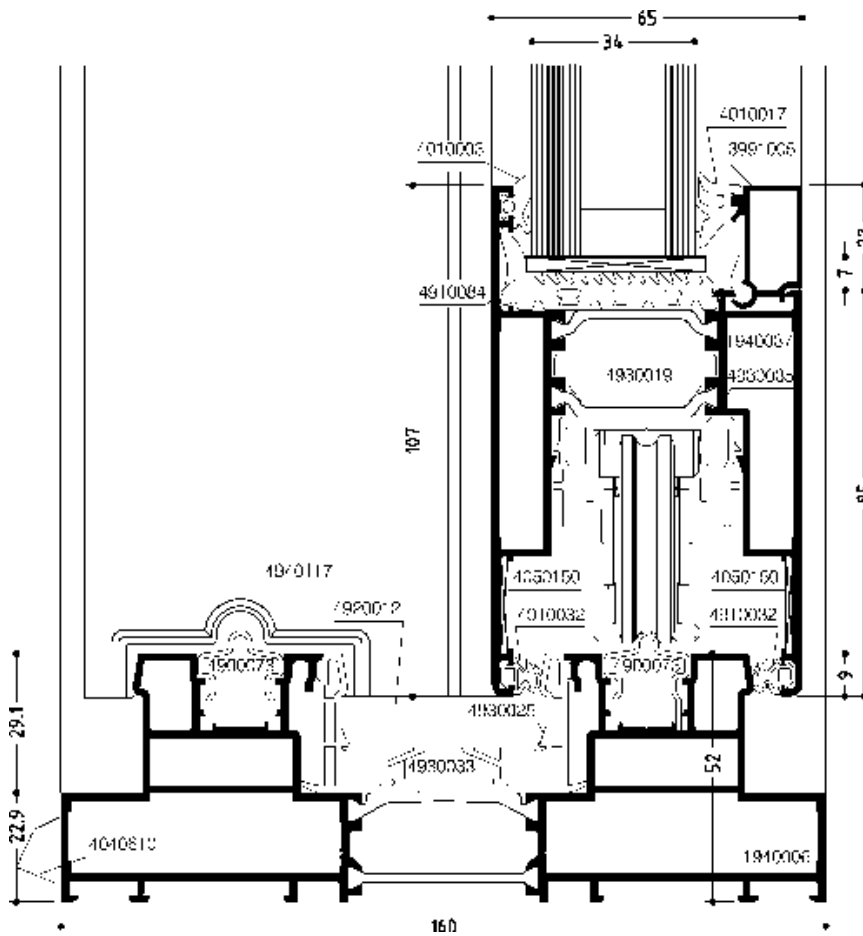

24



DOC-0000883345

Flügelprofil im
Blendrahmen,
einbruchhemmend
*Sash profile in
frame,
burglar resistant*

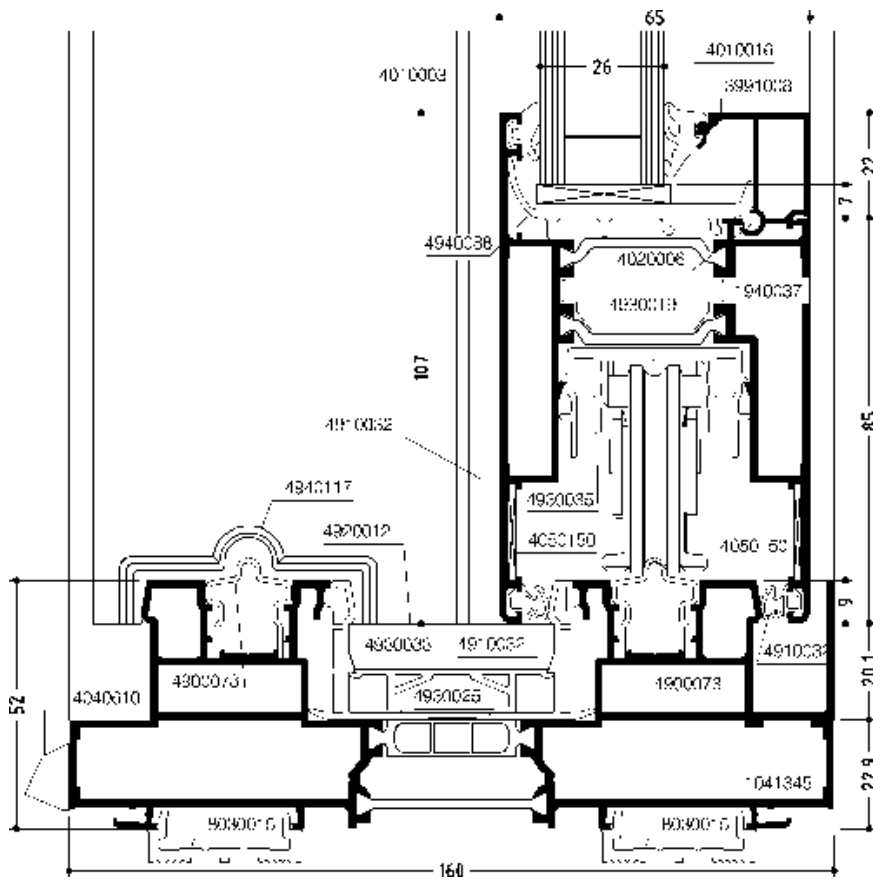

DOC-0000919959

Flügelprofil im
Blendrahmen mit
Bauanschlussprofil
8030015

*Sash profile in
frame with profile
for junction to
structure 8030015*

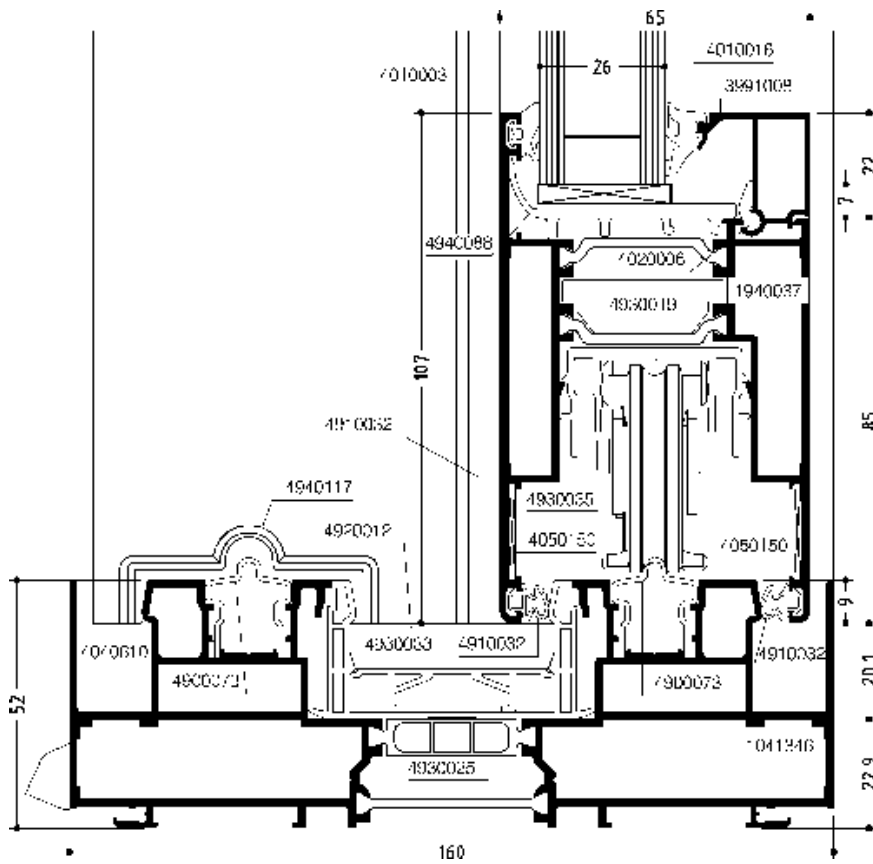

DOC-0000919984

Flügelprofil im
Blendrahmen

Sash profile in
frame

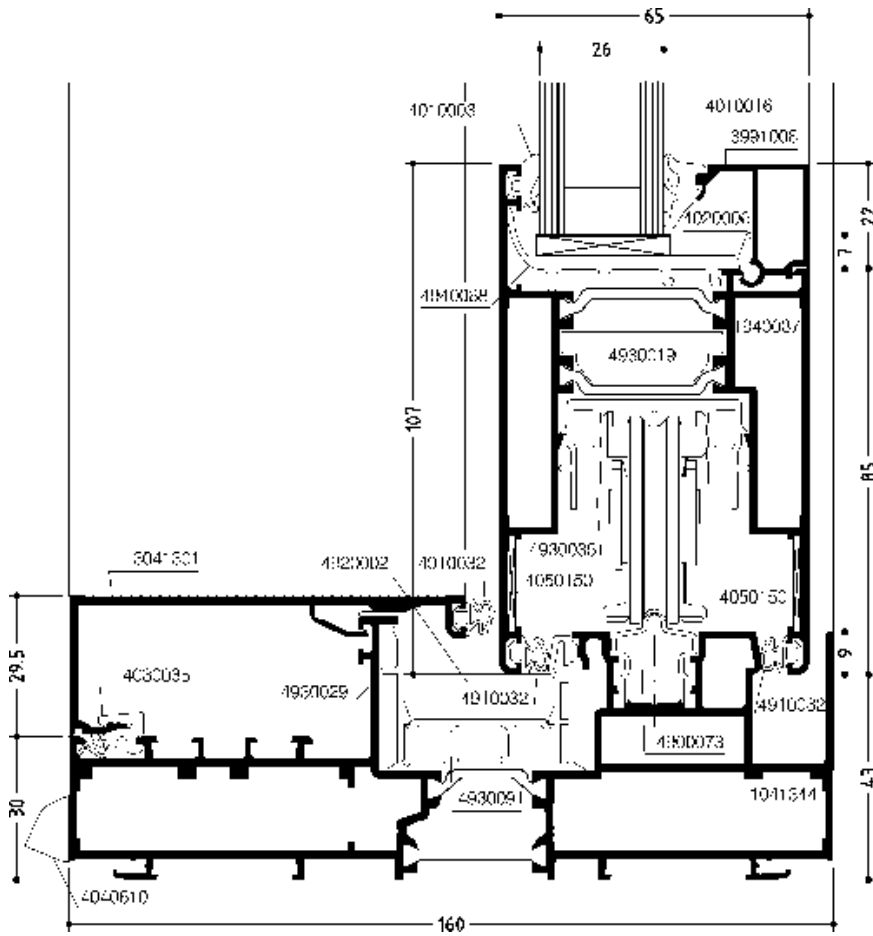

DOC-0000922917

Flügelprofil im
Blendrahmen
1041344 mit
Abdeckprofil
3041301

*Sash profile in
frame 1041344
with cover profile
3041301*

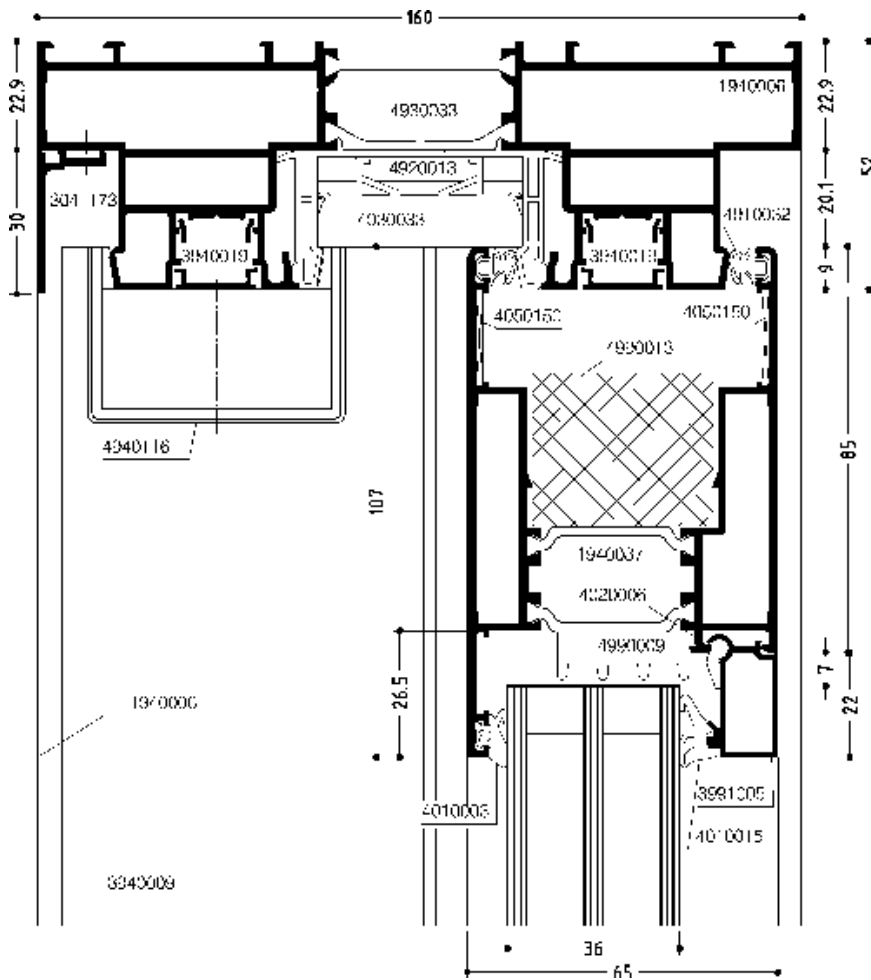

DOC-0000920523

Hochwärme-
dämmend, Flügel-
profil im Blendrah-
men

*High thermal
insulation, sash
profile in frame*



DOC-0000964158

Verhakungszone
Typ 2,
mit Verriegelung
*Hooking zone type
2,
with locking*

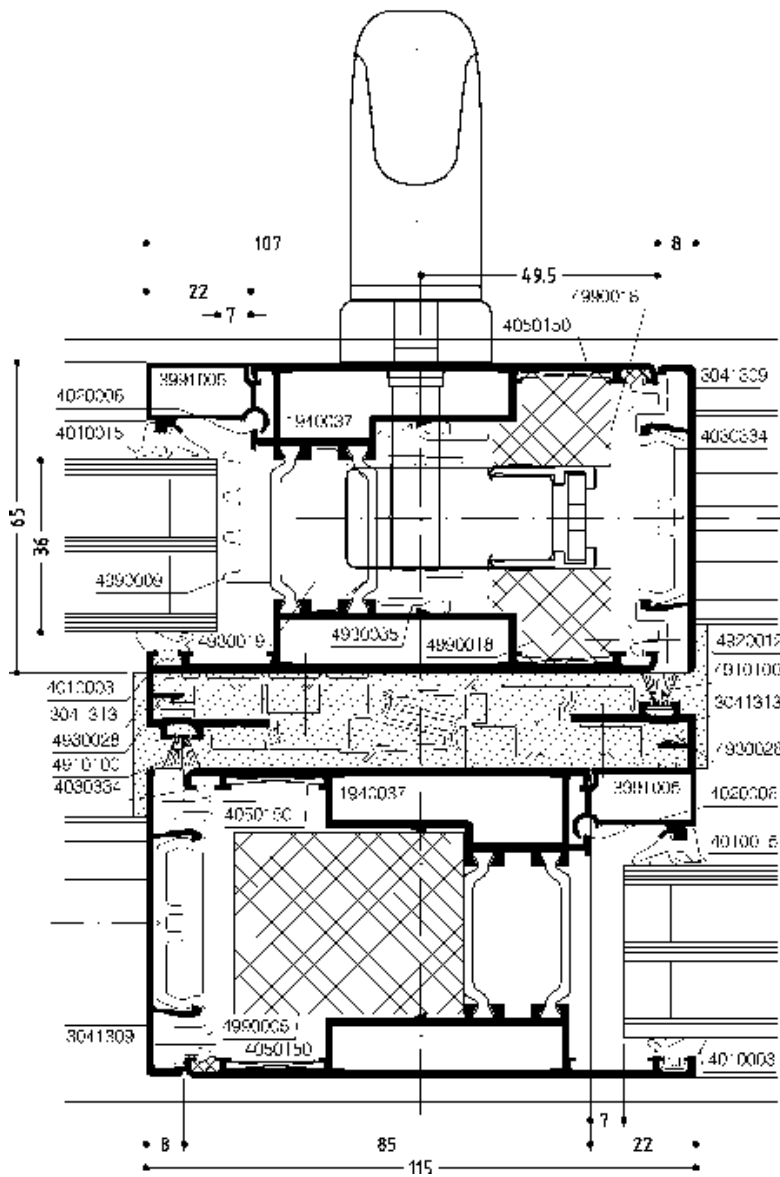



DOC-0000964399

Festverglasung,
Verhakungszone
Typ 2
hochwärmedäm-
mend,
mit Verriegelung

*Fixed glazing,
hooking zone type
2,
high insulation,
with locking*

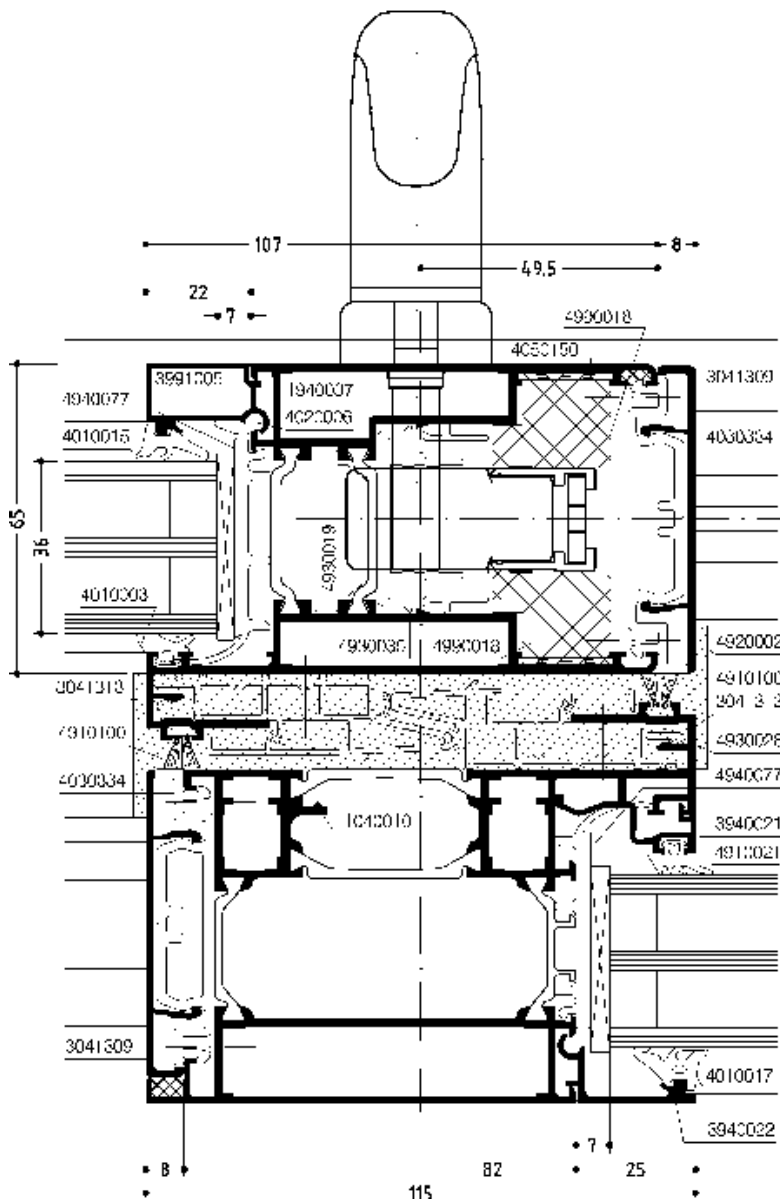

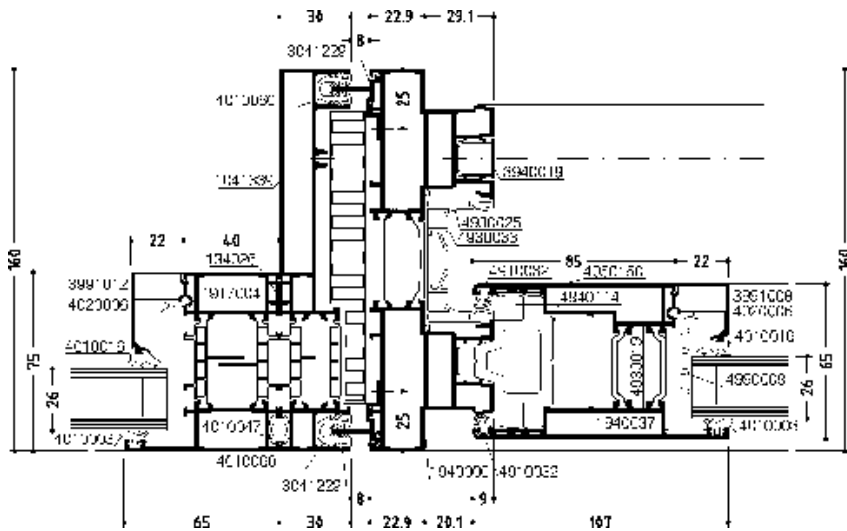

31

DOC-0000900649

Verbindung zu
WICLINE 75

Connection to
WICLINE 75

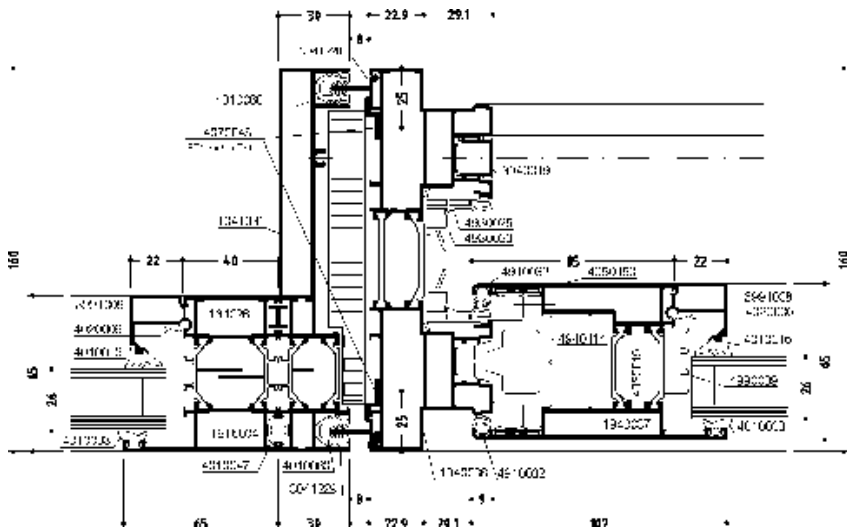

32

DOC-0000900555

Verbindung zu
WICLINE 65

Connection to
WICLINE 65

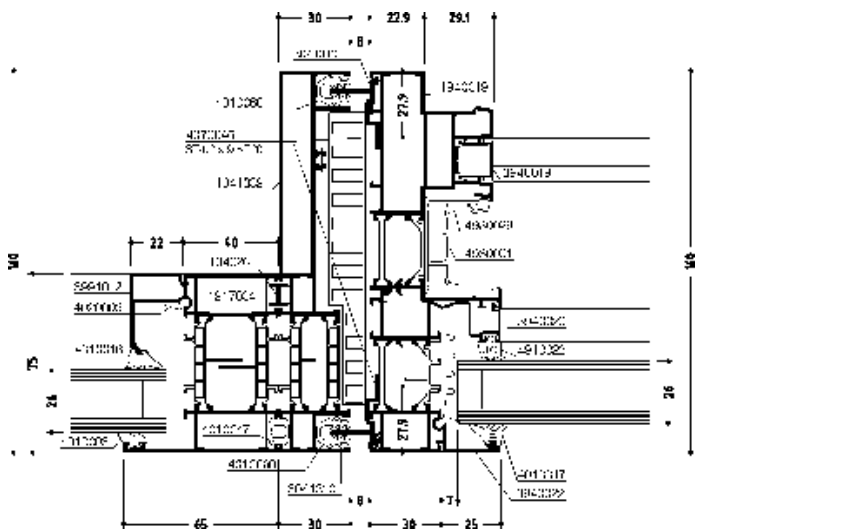

33

DOC-0000981763

Verbindung zu
WICLINE 75, Fest-
verglasung

Connection to
WICLINE 75, fixed
glazing

Konstruktionsschnitte Übersicht
Survey of construction sections

Blendrahmen dreibahnig:
Triple track frame profile:

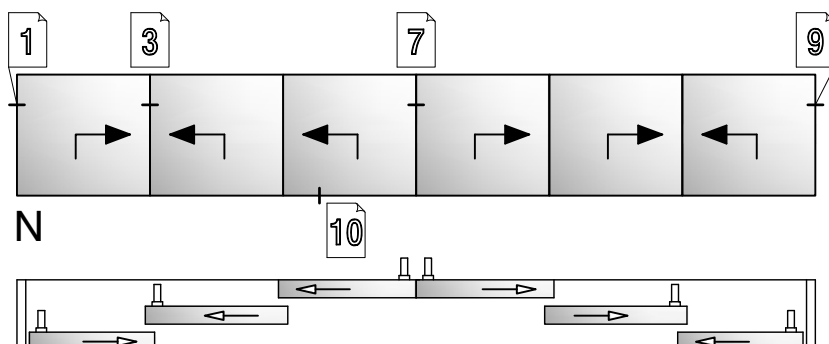
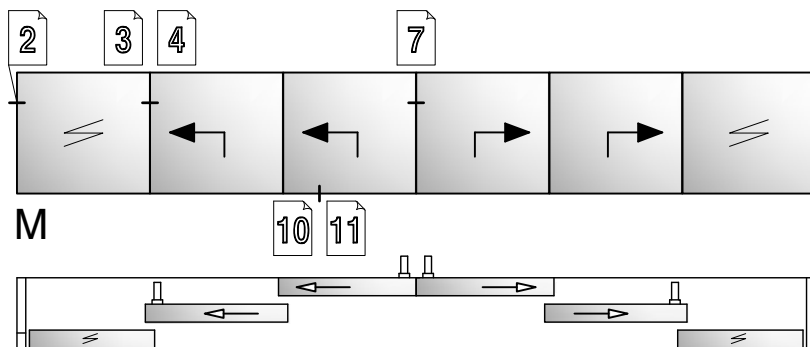
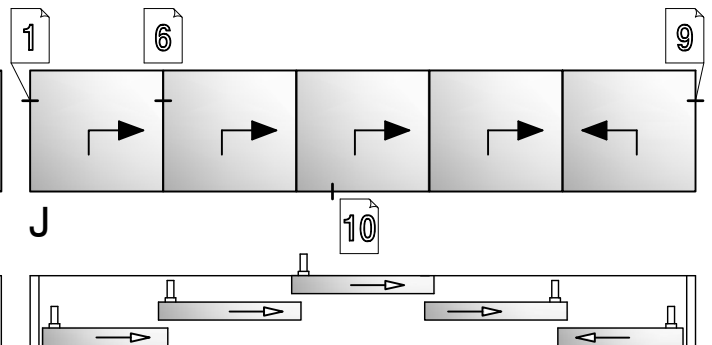
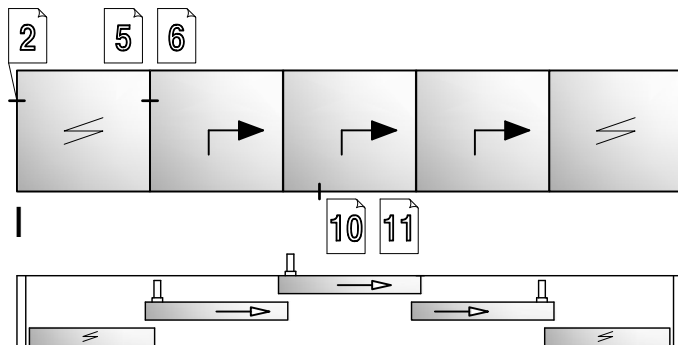
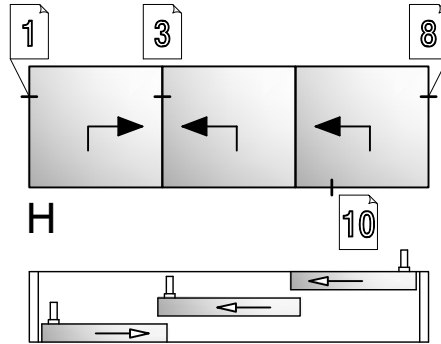
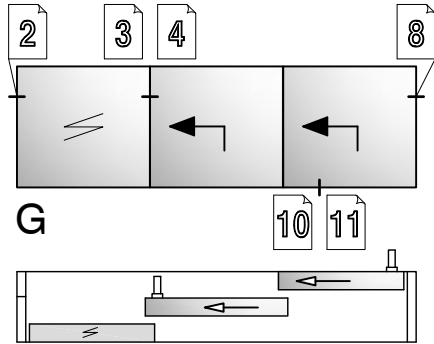

Hinweis / Note:

➡ Symbol für Hebe-Schiebelemente
Symbol for lifting sliding units

≡ Festfeld, festgestellter Flügel
Fixed glazing, fixed leaf

└ Griffseite
Handle side

1 Zweibahnig
Double track

1 Dreibahnig
Triple track

WICSLIDE 160

Konstruktionsschnitte Übersicht Survey of construction sections

Blendrahmen dreibahnig: Triple track frame profile:

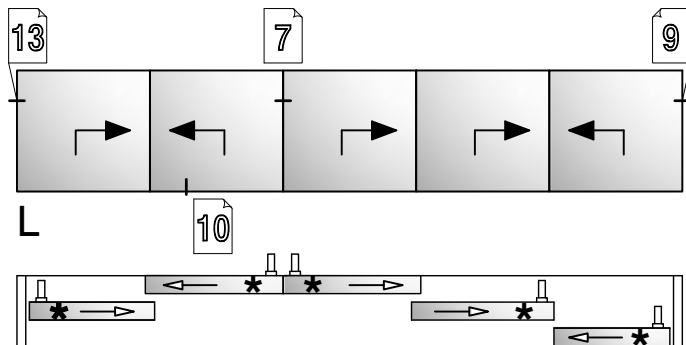
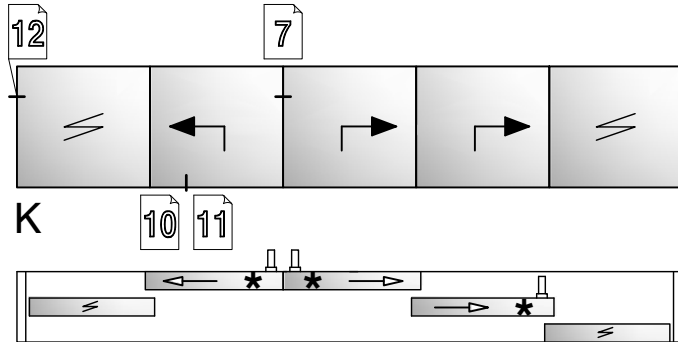

Hinweis / Note:

↔ Symbol für Hebe-Schiebeelemente
Symbol for lifting sliding units

≡ Festfeld, festgestellter Flügel
Fixed glazing, fixed leaf

└ Griffseite
Handle side

1 Zweibahnig
Double track

1 Dreibahnig
Triple track

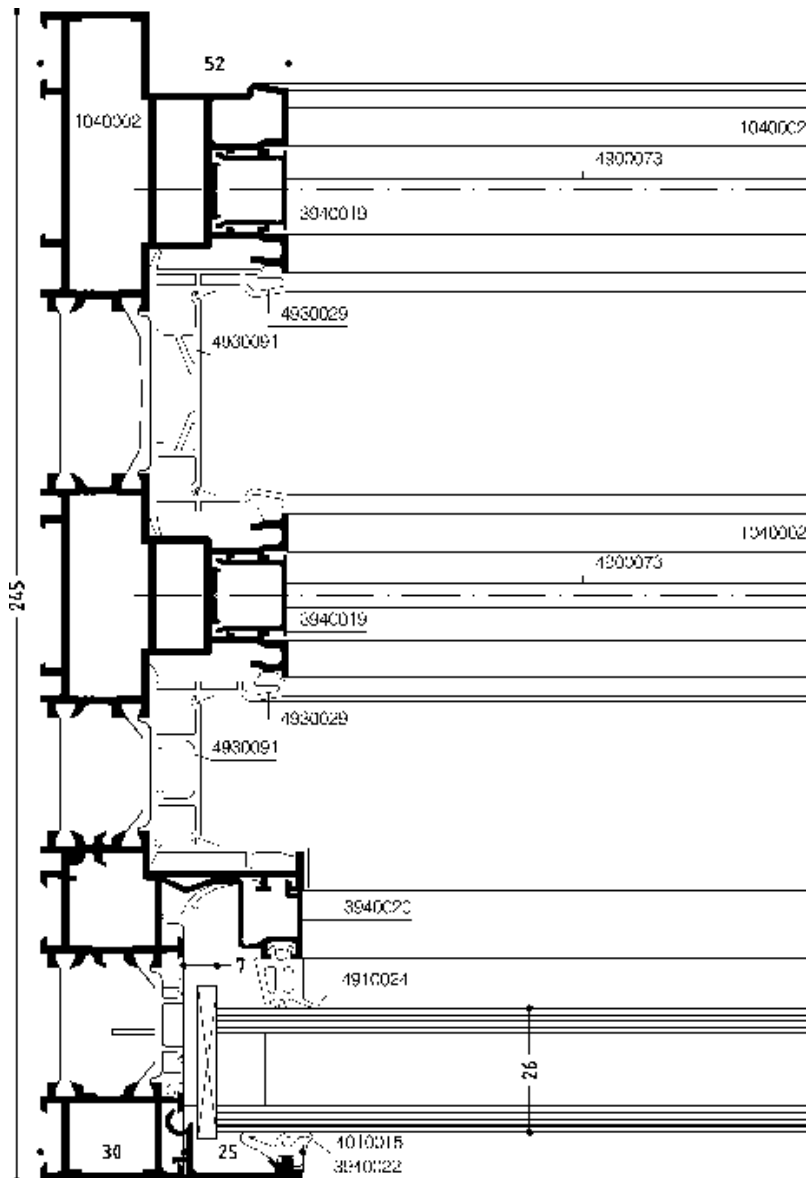

DOC-0000974951

Festverglasung
Fixed glazing



DOC-0000975210

Verhakungszone
Standard
mit Verriegelung
und
Festverglasung

*Hooking zone
standard,
with locking and
fixed glazing*

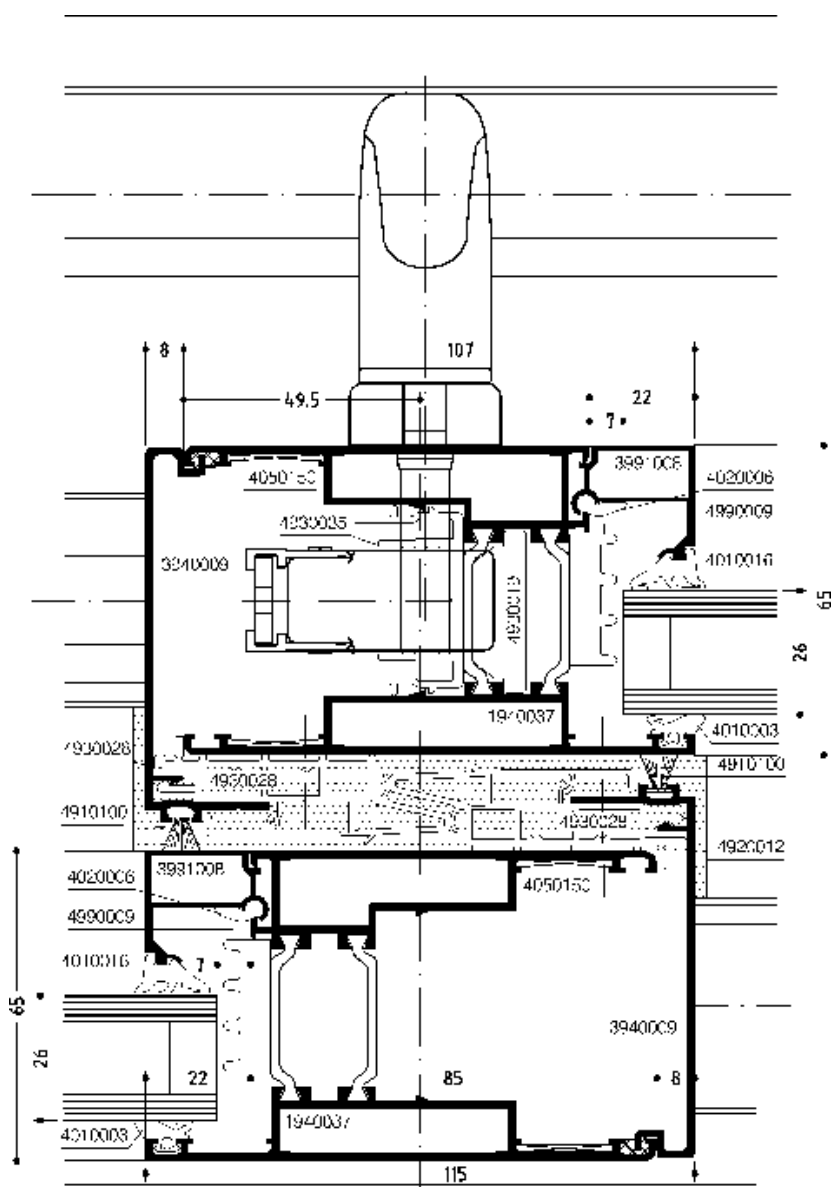



DOC-0000975250

Verhakungszone
mit Verriegelung
und Festverglä-
sung

*Hooking zone with
locking and fixed
glazing*

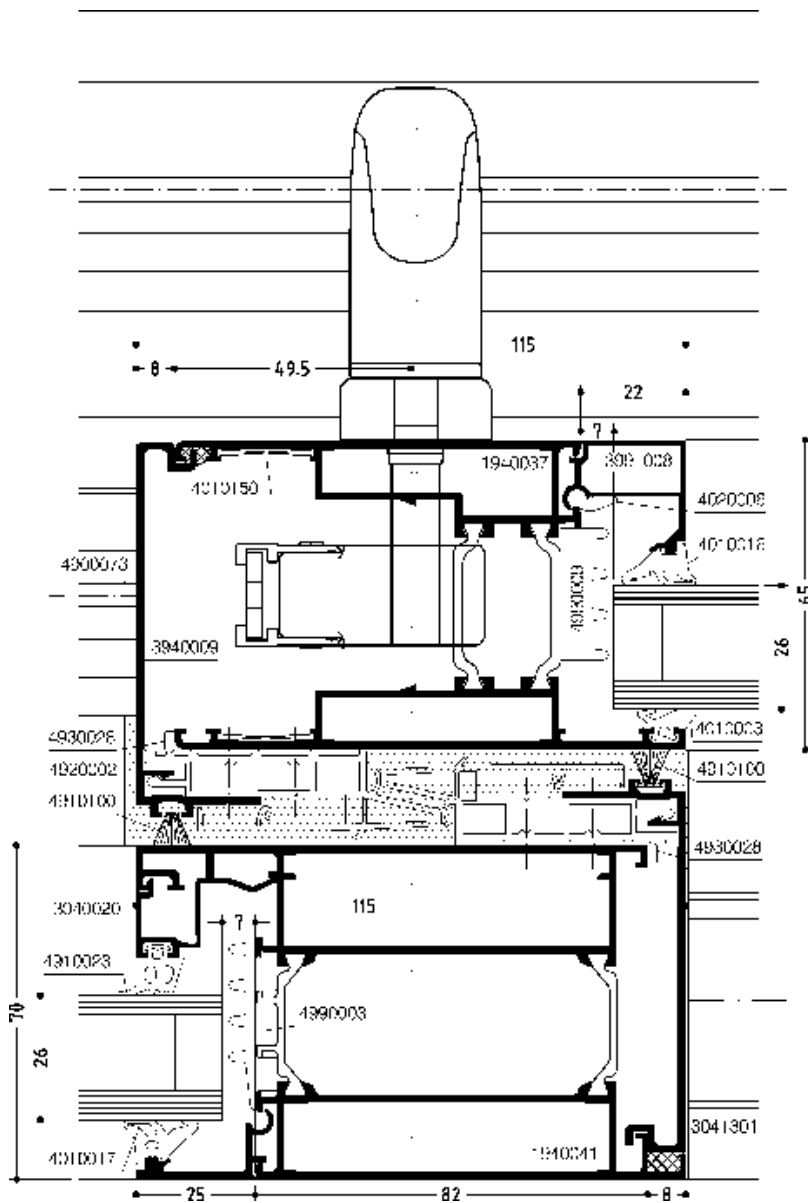



DOC-0000975261

Festverglasung,
Verhakungzone
Typ 2,
mit Verriegelung

*Fixed glazing,
hooking zone type
2,
with locking*

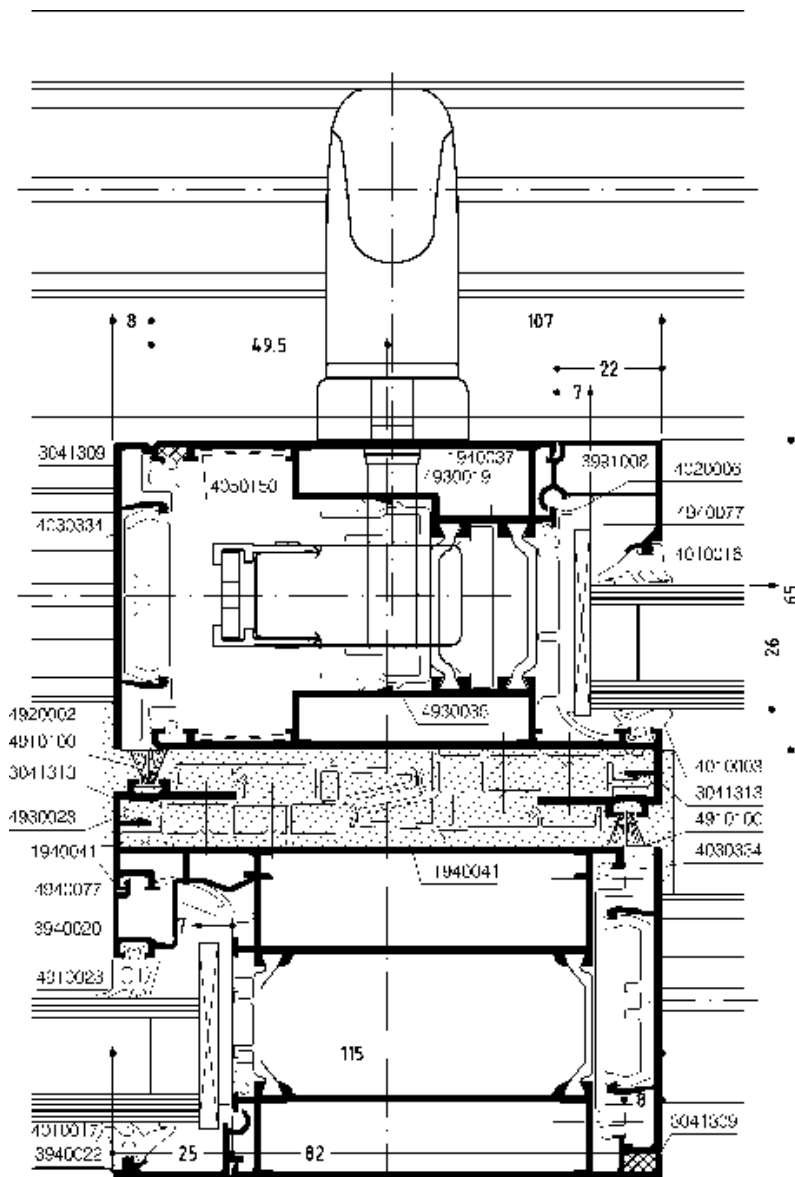

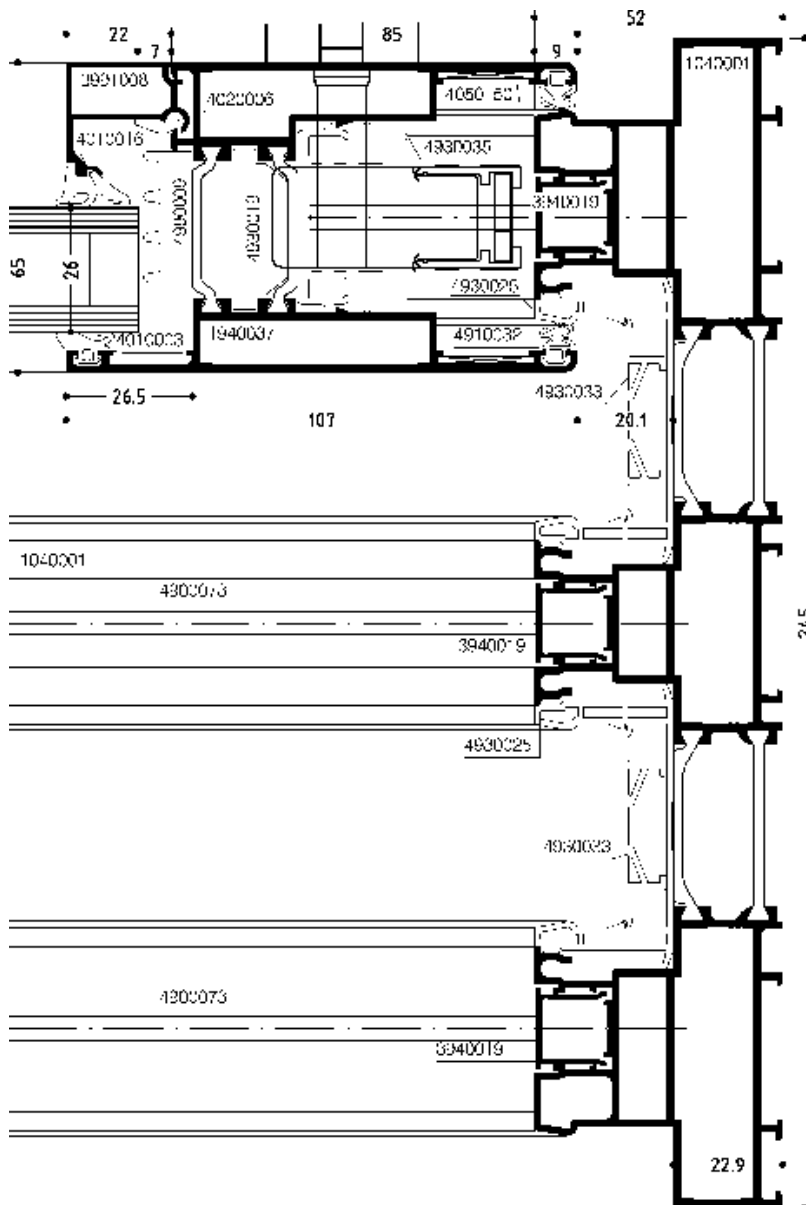

DOC-0000974969

Flügelprofil in
Blendrahmen
1040001, 3-bahrig

Sash profile in
frame 1040001, 3
rail

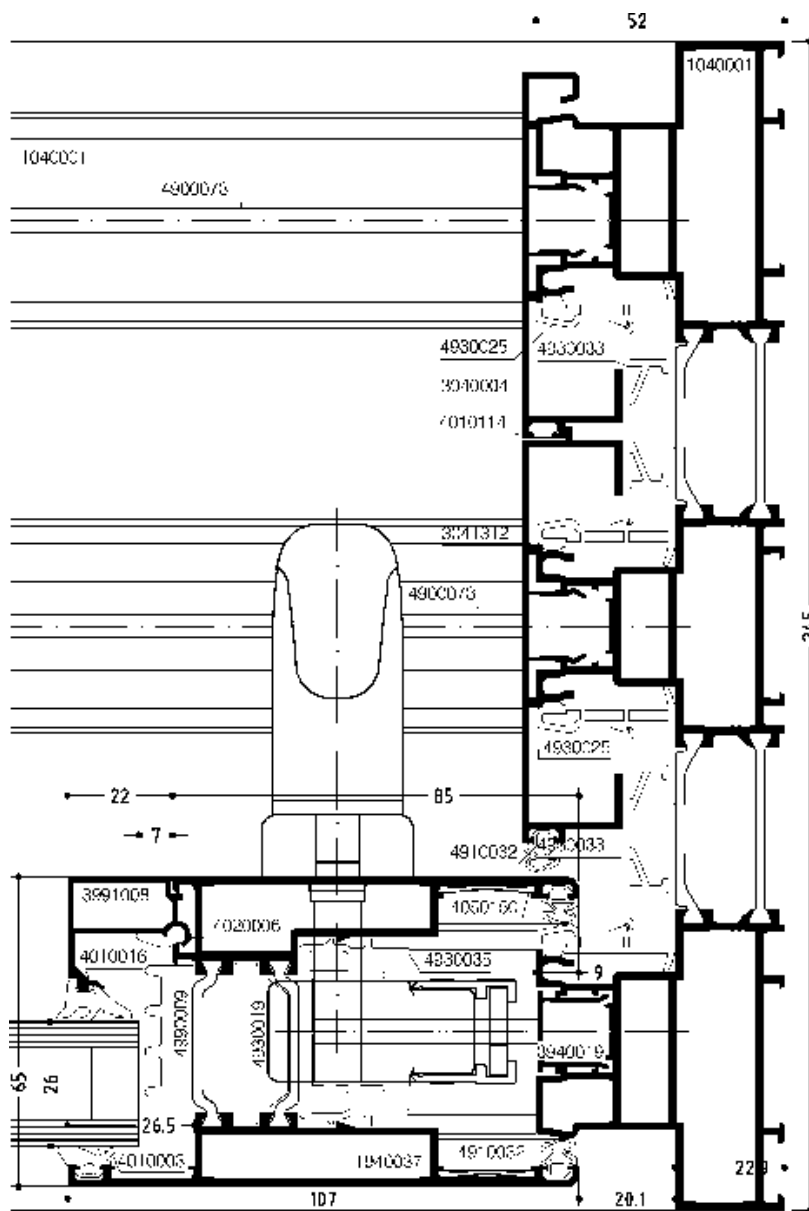

DOC-0000975031

Flügelprofil im
Blendrahmen mit
Abdeckprofilen
seitlich

*Sash profile in
fame with lateral
cover profiles*

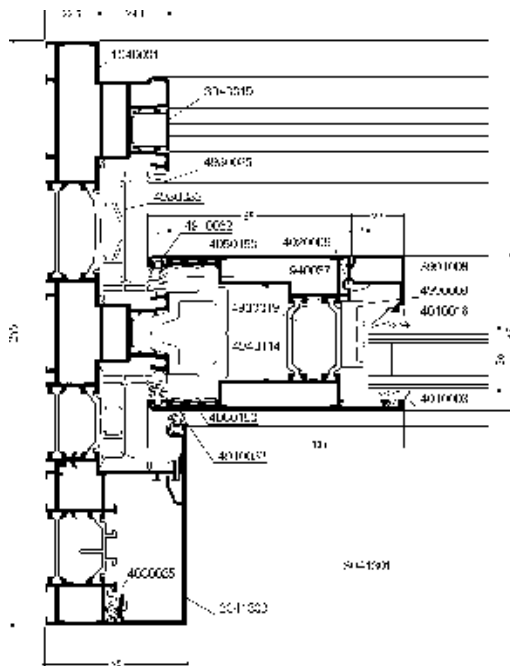

DOC-0001012718

Festverglasung
Fixed glazing

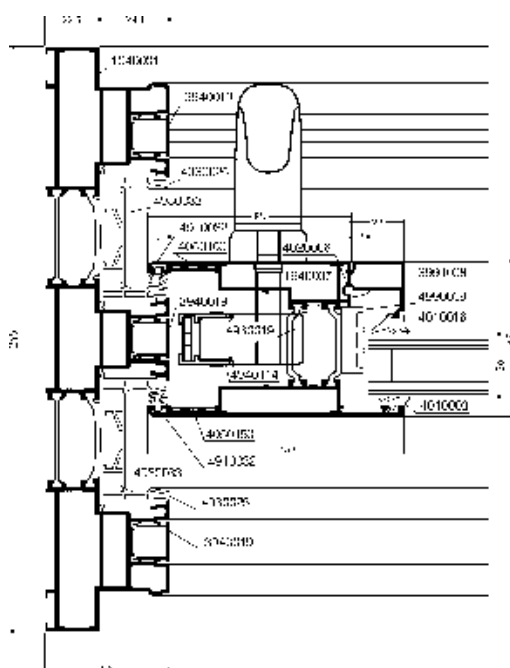

DOC-0001022485

Flügelprofil in
Blendrahmen
*Sash profile in
frame*

Glasleistenprofile, Auswahltabellen Glazing bead profiles, selection tables

Die Auswahltable zeigt die verschiedenen Glasleistenprofile und die zulässigen Füllungsdicken mit Toleranzen.

Die Auswahltable ist für Trockenverglasung mittels EPDM-Dichtungsprofilen ausgelegt.

Bei der Verglasung sind die Vorschriften der Glashersteller und der einschlägigen Fachverbände zu beachten, insbesondere die Forderung nach einem funktionssicheren Dampfdruckausgleich und Entwässerung der Hohlräume im Glasfalzraum zwischen Isolierglas-Scheibenkante und Falzgrund.

Die Auswahltabellen ermöglichen eine theoretische Vorplanung. Die Glastoleranzen sind zu berücksichtigen. Um extreme Toleranzen der Profile und Füllungsdicken ausgleichen zu können, ist es vorteilhaft, bei der Planung die Füllungsdicken aus den punktschraffierten Feldern der Auswahltable zu entnehmen, Bei der Montage sind die Vorgaben praktisch zu prüfen und gegebenenfalls durch Variationen der Einrolldichtungen, dargestellt durch die schraffierten Felder, die notwendige Vorspannung aufzubringen.

The selection table indicates the different glazing bead profiles and admissible infill thicknesses with tolerances.

The selection table is outlaid for dry glazing with EPDM glazing gasket profiles.

Consider the prescriptions of glass manufacturers and relevant professional associations while glazing, especially the demand for a functional and secured air pressure equalization and drainage of hollow spaces in glazing rebate area between insulation glass pane edge and rebate base.

The selection tables enable a preliminary theoretical planning. The glass tolerances have to be considered while planning. It is advantageous to select infill thicknesses from the dot-hatched columns of selection table in order to compensate extreme tolerances of profiles and infill thicknesses. Check the specifications practically and when required, implement the necessary prestressing by varying the rolled gaskets listed in the hatched columns.

empfohlen
recommended

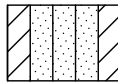

4020006

Anwendung bei beschichteten Profilen
Application on coated profiles



4020049

Anwendung bei eloxierten Profilen
Application on anodized profiles



1

Bautiefe (BT) 65 / Construction depth (CD) 65

Glasleistenprofile Glazing bead profiles		a) Füllungsdicke ±1 mm Infill thickness ±1 mm					mit Einrolldichtung Nr.: with rolled gasket no.:	
Nr. / No. 22 mm	b) mm	4910004	4010015 blau / blue	4010016 rot / red	4010017 grün / green	4010018		
3991001	2	50	49	48	47	46		
3991002	5	47	46	45	44	43		
3991003	9	43	42	41	40	39		
3991004	12	40	39	38	37	36		
3991005	15	37	36	35	34	33		
3991006	19	33	32	31	30	29		
3991007	22	30	29	28	27	26		
3991008	24	28	27	26	25	24		
3991009	26	26	25	24	23	22		
3991010	29	23	22	21	20	19		
3991011	32	20	19	18	17	16		
3991012	34	18	17	16	15	14		
3991013	37	15	14	13	12	11		
3991014	41	11	10	9	8	7		
3991015	45	7	6	5	4	3		

- 1 Bautiefe auswählen
Select construction depth
- 2 Füllungsdicke auswählen
Select infill thickness
- 3 Entsprechende Glasleiste
Appropriate glazing bead
- 4 Entsprechende innere Verglasungsdichtung
Appropriate inner glazing gasket

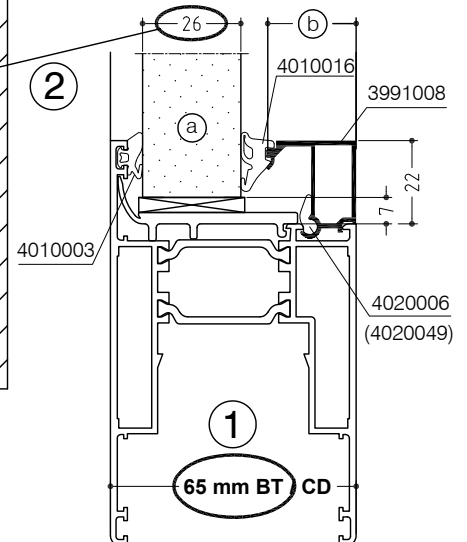

Bautiefe (BT) 65 / Construction depth (CD) 65

Glasleistenprofile Glazing bead profiles		a) Füllungsdicke ±1 mm Infill thickness ±1 mm					mit Einrolldichtung Nr.: with rolled gasket no.:
Nr. / No. 22 mm	b) mm	4910004	4010015 blau / blue	4010016 rot / red	4010017 grün / green	4010018	
3991001	2	50	49	48	47	46	
3991002	5	47	46	45	44	43	
3991003	9	43	42	41	40	39	
3991004	12	40	39	38	37	36	
3991005	15	37	36	35	34	33	
3991006	19	33	32	31	30	29	
3991007	22	30	29	28	27	26	
3991008	24	28	27	26	25	24	
3991009	26	26	25	24	23	22	
3991010	29	23	22	21	20	19	
3991011	32	20	19	18	17	16	
3991012	34	18	17	16	15	14	
3991013	37	15	14	13	12	11	
3991014	41	11	10	9	8	7	
3991015	45	7	6	5	4	3	

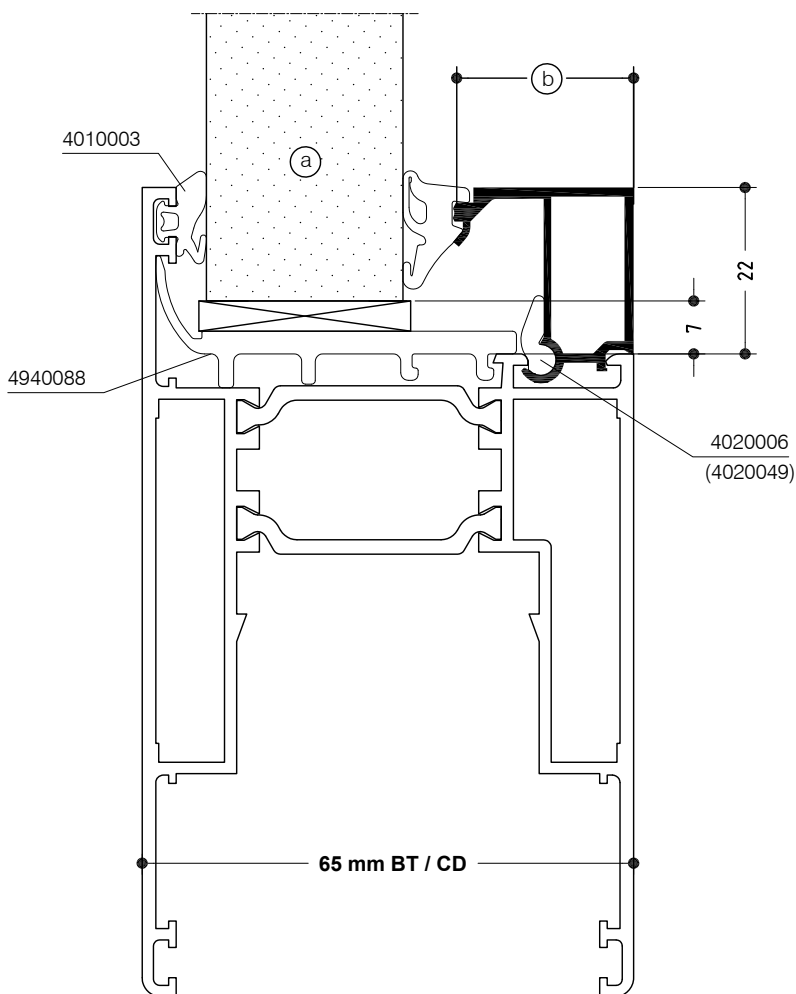

Glasleistenprofile für Nassverglasung, Auswahltabellen

Glazing bead profiles for wet glazing, selection tables

Die Auswahltabelle zeigt die verschiedenen Glasleistenprofile und die zulässigen Füllungsdicken mit Toleranzen.

Die Auswahltabelle ist für Nassverglasung ausgelegt.

Bei der Verglasung sind die Vorschriften der Glashersteller und der einschlägigen Fachverbände zu beachten, insbesondere die Forderung nach einem funktionssicheren Dampfdruckausgleich und Entwässerung der Hohlräume im Glasfalzraum zwischen Isolierglas-Scheibenkante und Falzgrund.

Die Auswahltabellen ermöglichen eine theoretische Vorplanung. Die Glastoleranzen sind zu berücksichtigen. Bei der Montage sind die Vorgaben praktisch zu prüfen.

The selection table shows the different glazing bead profiles and the admissible infill thicknesses with tolerances.

The selection table is designed for wet glazing.

Please follow the glazing instructions of glass manufacturers and relevant professional associations, especially the demand for a functionally secure air pressure equalization and drainage of cavities in glazing rebate area between insulation glass pane edge and rebate base.

The selection tables enable a preliminary theoretical planning. The glass tolerances have to be considered while planning. Check the specifications practically.

Bautiefe (BT) 65 / Construction depth (CD) 65

Glasleistenprofile Glazing bead profiles		a) Füllungsdicke ±1 mm Infill thickness ±1 mm			
Nr. / No. 22 mm	b) mm	Spalt / Gap 4.5 mm	Spalt / Gap 5.5 mm	Spalt / Gap 6.5 mm	Spalt / Gap 7.5 mm
3991001	2	50	49	48	47
3991264	5	47	46	45	44
3991265	9	43	42	41	40
3991266	12	40	39	38	37
3991267	15	37	36	35	34
3991268	19	33	32	31	30
3991269	22	30	29	28	27
3991270	24	28	27	26	25
3991271	26	26	25	24	23
3991272	29	23	22	21	20
3991273	32	20	19	18	17
3991274	34	18	17	16	15
3991275	37	15	14	13	12
3991276	41	11	10	9	8
3991277	45	7	6	5	4

Nassverglasung / Wet glazing

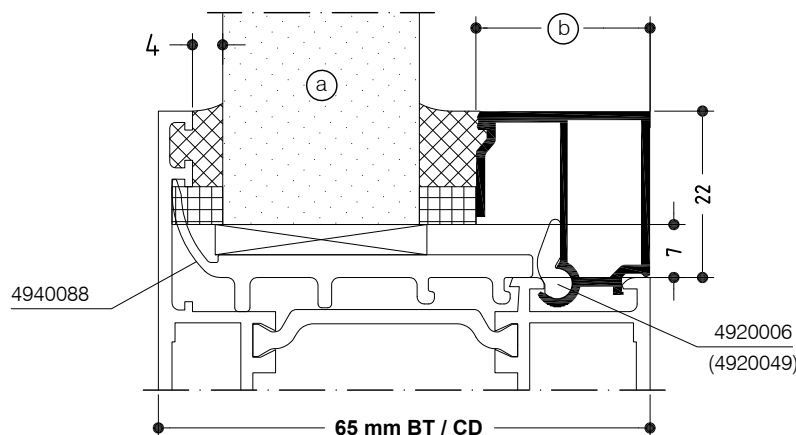

Bautiefe (BT) 65 / Construction depth (CD) 65

Adapter Adapter	Dichtung innen Inner gasket		a) Füllungsdicke ±1 mm Infill thickness ±1 mm					mit Einrolldichtung Nr.: with rolled gasket no.:	
	Nr. / No.	ⓐ mm	Nr. / No.	ⓑ mm	4910004	4010015 blau / blue	4010016 rot / red	4010017 grün / green	4010018
3940021	8	8	4910021	4.5	47	46	45	44	43
			4910022	6.5	45	44	43	42	41
			4910023	8.5	43	42	41	40	39
			4910024	10.5	41	40	39	38	37
			4910021	4.5	39	38	37	36	35
			4910022	6.5	37	36	35	34	33
			4910023	8.5	35	34	33	32	31
			4910021	4.5	33	32	31	30	29
			4910022	6.5	31	30	29	28	27
			4910023	8.5	29	28	27	26	25
			4910024	10.5	27	26	25	24	23

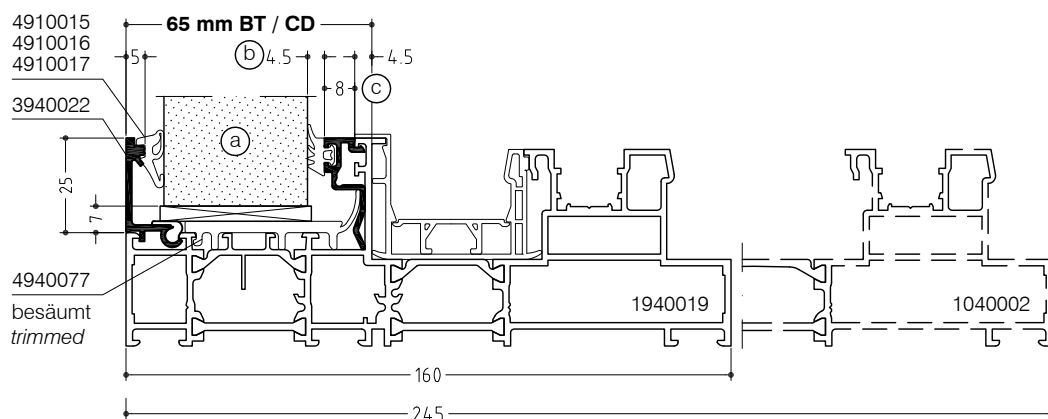

WICSLIDE 160





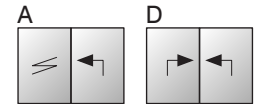

Standard Beschläge

Standard hardware

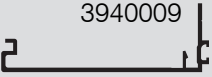
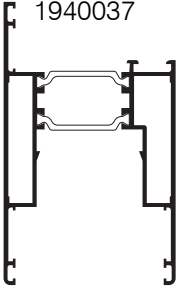
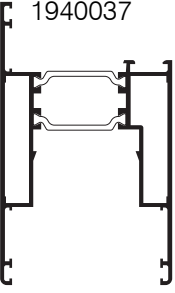
Zulässige Flügelgrößen

Admissible sash sizes









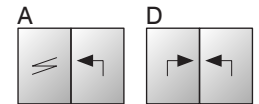

 <p>3940009</p> <p>Flügelaufsatzprofil Sash supplementary profile</p>		 <p>1940037</p>				 <p>1940037</p>											
	(Pa)	400	800	1200	-	400	800	1200	-	-	-	-	-	-	-	-	-
	(Pa)	-	-	-	-	-	-	-	-	-	-	-	-	-	-	-	-
max.	FAB (m)	3.2	3.2	3.2	-	3.2	3.2	3.2	-	-	-	-	-	-	-	-	-
	FAH (m)	3.2	2.7	2.4	-	3.2	2.7	2.4	-	-	-	-	-	-	-	-	-
min.	FAB (m)	0.77	0.77	0.77	-	1.38	1.38	1.38	-	-	-	-	-	-	-	-	-
	FAH (m)	1.2	1.2	1.2	-	1.2	1.2	1.2	-	-	-	-	-	-	-	-	-
MV / MB	FAB (m)	-	-	-	-	-	-	-	-	-	-	-	-	-	-	-	-
	FAH (m)	-	-	-	-	-	-	-	-	-	-	-	-	-	-	-	-
	min.	FAB (m)	0.96	0.96	0.96	-	1.38	1.38	1.38	-	-	-	-	-	-	-	-
	FAH (m)	1.31	1.31	1.31	-	1.31	1.31	1.31	-	-	-	-	-	-	-	-	-
	min.	FAB (m)	-	-	-	-	-	-	-	-	-	-	-	-	-	-	-
	FAH (m)	-	-	-	-	-	-	-	-	-	-	-	-	-	-	-	-
	max. (kg)	300				400				-				-			

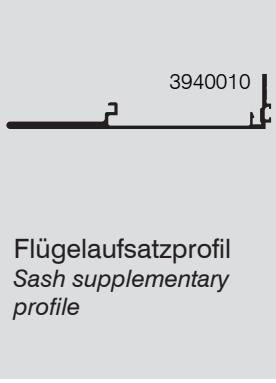
WICSLIDE 160

Standard Beschläge
Standard hardware

Zulässige Flügelgrößen
Admissible sash sizes



 <p>3940010 Flügelauflaufprofil Sash supplementary profile</p>		1940037				1940037												
	(Pa)	400	800	1200	-	400	800	1200	-	-	-	-	-	-	-	-	-	
	(Pa)	-	-	-	-	-	-	-	-	-	-	-	-	-	-	-	-	
																		
	max.	FAB (m)	3.2	3.2	3.2	-	3.2	3.2	3.2	-	-	-	-	-	-	-	-	
		FAH (m)	3.4	3.2	2.9	-	3.4	3.2	2.9	-	-	-	-	-	-	-	-	
	min.	FAB (m)	0.77	0.77	0.77	-	1.38	1.38	1.38	-	-	-	-	-	-	-	-	
		FAH (m)	1.2	1.2	1.2	-	1.2	1.2	1.2	-	-	-	-	-	-	-	-	
	MV / MB	FAB (m)	-	-	-	-	-	-	-	-	-	-	-	-	-	-	-	
		FAH (m)	-	-	-	-	-	-	-	-	-	-	-	-	-	-	-	
	min.	FAB (m)	0.96	0.96	0.96	-	1.38	1.38	1.38	-	-	-	-	-	-	-	-	
		FAH (m)	1.31	1.31	1.31	-	1.31	1.31	1.31	-	-	-	-	-	-	-	-	
	min.	FAB (m)	-	-	-	-	-	-	-	-	-	-	-	-	-	-	-	
		FAH (m)	-	-	-	-	-	-	-	-	-	-	-	-	-	-	-	
	max.	max. (kg)	300				400				-				-			

WICSLIDE 160

Standard Beschläge

Standard hardware

Zulässige Flügelgrößen

Admissible sash sizes

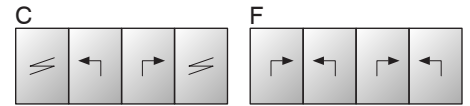

1940037

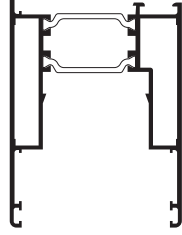

1940037

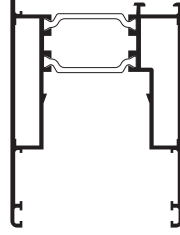

	(Pa)	400	800	1200	-	400	800	1200	-	-	-	-	-	-	-	-	-
	(Pa)	-	-	-	-	-	-	-	-	-	-	-	-	-	-	-	-
	max.	FAB (m)	3.2	3.2	3.2	-	3.2	3.2	3.2	-	-	-	-	-	-	-	-
		FAH (m)	3.0	2.4	2.2	-	3.0	2.4	2.2	-	-	-	-	-	-	-	-
	min.	FAB (m)	0.77	0.77	0.77	-	1.38	1.38	1.38	-	-	-	-	-	-	-	-
		FAH (m)	1.2	1.2	1.2	-	1.2	1.2	1.2	-	-	-	-	-	-	-	-
MV / MB		FAB (m)	-	-	-	-	-	-	-	-	-	-	-	-	-	-	-
		FAH (m)	-	-	-	-	-	-	-	-	-	-	-	-	-	-	-
	min.	FAB (m)	0.96	0.96	0.96	-	1.38	1.38	1.38	-	-	-	-	-	-	-	-
		FAH (m)	1.31	1.31	1.31	-	1.31	1.31	1.31	-	-	-	-	-	-	-	-
	min.	FAB (m)	-	-	-	-	-	-	-	-	-	-	-	-	-	-	-
		FAH (m)	-	-	-	-	-	-	-	-	-	-	-	-	-	-	-
	max. (kg)	300				400				-				-			

WICSLIDE 160

Standard Beschläge

Standard hardware

Zulässige Flügelgrößen

Admissible sash sizes

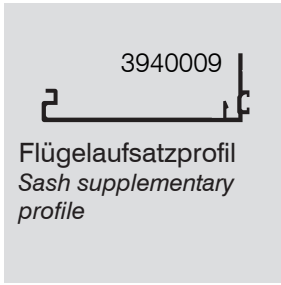
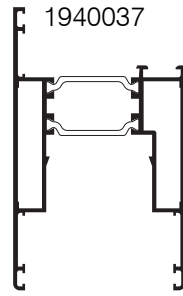
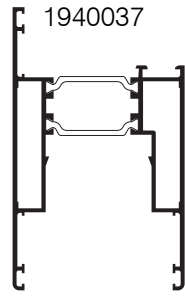
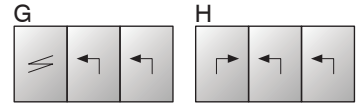

	(Pa)	400	800	1200	-	400	800	1200	-	-	-	-	-	-	-	-	-
	(Pa)	-	-	-	-	-	-	-	-	-	-	-	-	-	-	-	-
	max.	FAB (m)	3.2	3.2	3.2	-	3.2	3.2	3.2	-	-	-	-	-	-	-	-
		FAH (m)	2.8	2.7	2.4	-	2.8	2.7	2.4	-	-	-	-	-	-	-	-
	min.	FAB (m)	0.77	0.77	0.77	-	1.38	1.38	1.38	-	-	-	-	-	-	-	-
		FAH (m)	1.2	1.2	1.2	-	1.2	1.2	1.2	-	-	-	-	-	-	-	-
MV / MB		FAB (m)	-	-	-	-	-	-	-	-	-	-	-	-	-	-	-
		FAH (m)	-	-	-	-	-	-	-	-	-	-	-	-	-	-	-
	min.	FAB (m)	0.96	0.96	0.96	-	1.38	1.38	1.38	-	-	-	-	-	-	-	-
		FAH (m)	1.31	1.31	1.31	-	1.31	1.31	1.31	-	-	-	-	-	-	-	-
	min.	FAB (m)	-	-	-	-	-	-	-	-	-	-	-	-	-	-	-
		FAH (m)	-	-	-	-	-	-	-	-	-	-	-	-	-	-	-
	max. (kg)	300				400				-				-			

WICSLIDE 160

Standard Beschläge

Standard hardware

Zulässige Flügelgrößen

Admissible sash sizes

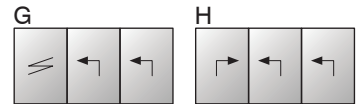

		1940037				1940037											
		 3940010 Flügelaufsatzprofil Sash supplementary profile															
	(Pa)	400	800	1200	-	400	800	1200	-	-	-	-	-	-	-	-	-
	(Pa)	-	-	-	-	-	-	-	-	-	-	-	-	-	-	-	-
	max.	FAB (m)	3.2	3.2	3.2	-	3.2	3.2	3.2	-	-	-	-	-	-	-	-
		FAH (m)	2.8	2.8	2.8	-	2.8	2.8	2.8	-	-	-	-	-	-	-	-
	min.	FAB (m)	0.77	0.77	0.77	-	1.38	1.38	1.38	-	-	-	-	-	-	-	-
		FAH (m)	1.2	1.2	1.2	-	1.2	1.2	1.2	-	-	-	-	-	-	-	-
MV / MB		FAB (m)	-	-	-	-	-	-	-	-	-	-	-	-	-	-	-
		FAH (m)	-	-	-	-	-	-	-	-	-	-	-	-	-	-	-
	min.	FAB (m)	0.96	0.96	0.96	-	1.38	1.38	1.38	-	-	-	-	-	-	-	-
		FAH (m)	1.31	1.31	1.31	-	1.31	1.31	1.31	-	-	-	-	-	-	-	-
	min.	FAB (m)	-	-	-	-	-	-	-	-	-	-	-	-	-	-	-
		FAH (m)	-	-	-	-	-	-	-	-	-	-	-	-	-	-	-
	max. (kg)	300				400				-				-			

WICSLIDE 160

Standard Beschläge
Standard hardware

Zulässige Flügelgrößen
Admissible sash sizes



1940037

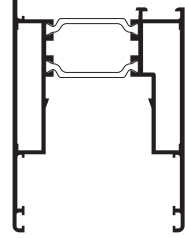

1940037

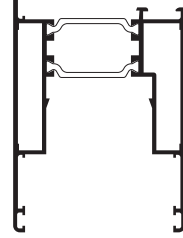

3041309

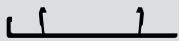

Flügelauflaufprofil
Sash supplementary
profile

	(Pa)	400	800	1200	-	400	800	1200	-	-	-	-	-	-	-	-	-
	(Pa)	-	-	-	-	-	-	-	-	-	-	-	-	-	-	-	-
	max.	FAB (m)	3.2	3.2	3.2	-	3.2	3.2	3.2	-	-	-	-	-	-	-	-
		FAH (m)	2.8	2.4	2.2	-	2.8	2.4	2.2	-	-	-	-	-	-	-	-
	min.	FAB (m)	0.77	0.77	0.77	-	1.38	1.38	1.38	-	-	-	-	-	-	-	-
		FAH (m)	1.2	1.2	1.2	-	1.2	1.2	1.2	-	-	-	-	-	-	-	-
MV / MB		FAB (m)	-	-	-	-	-	-	-	-	-	-	-	-	-	-	-
		FAH (m)	-	-	-	-	-	-	-	-	-	-	-	-	-	-	-
	min.	FAB (m)	0.96	0.96	0.96	-	1.38	1.38	1.38	-	-	-	-	-	-	-	-
		FAH (m)	1.31	1.31	1.31	-	1.31	1.31	1.31	-	-	-	-	-	-	-	-
	min.	FAB (m)	-	-	-	-	-	-	-	-	-	-	-	-	-	-	-
		FAH (m)	-	-	-	-	-	-	-	-	-	-	-	-	-	-	-
	max. (kg)	300				400				-				-			

WICSLIDE 160

Standard Beschläge

Standard hardware

Zulässige Flügelgrößen

Admissible sash sizes

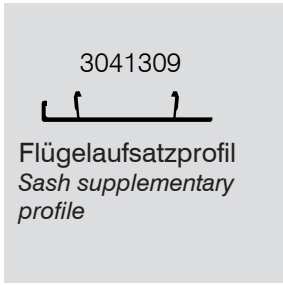
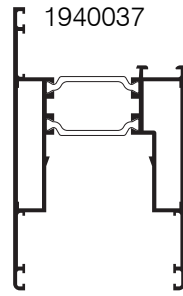
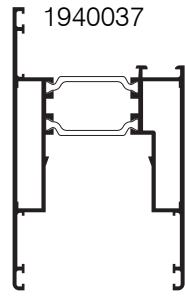
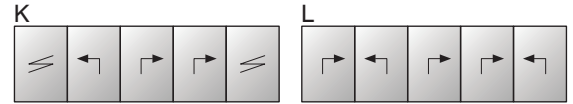

	(Pa)	400	800	1200	-	400	800	1200	-	-	-	-	-	-	-	-	-
	(Pa)	-	-	-	-	-	-	-	-	-	-	-	-	-	-	-	-
	max.	FAB (m)	3.2	3.2	3.2	-	3.2	3.2	3.2	-	-	-	-	-	-	-	-
		FAH (m)	2.8	2.7	2.4	-	2.8	2.7	2.4	-	-	-	-	-	-	-	-
	min.	FAB (m)	0.77	0.77	0.77	-	1.38	1.38	1.38	-	-	-	-	-	-	-	-
		FAH (m)	1.2	1.2	1.2	-	1.2	1.2	1.2	-	-	-	-	-	-	-	-
MV / MB		FAB (m)	-	-	-	-	-	-	-	-	-	-	-	-	-	-	-
		FAH (m)	-	-	-	-	-	-	-	-	-	-	-	-	-	-	-
	min.	FAB (m)	0.96	0.96	0.96	-	1.38	1.38	1.38	-	-	-	-	-	-	-	-
		FAH (m)	1.31	1.31	1.31	-	1.31	1.31	1.31	-	-	-	-	-	-	-	-
	min.	FAB (m)	-	-	-	-	-	-	-	-	-	-	-	-	-	-	-
		FAH (m)	-	-	-	-	-	-	-	-	-	-	-	-	-	-	-
	max. (kg)	300				400				-				-			

WICSLIDE 160

Standard Beschläge

Standard hardware

Zulässige Flügelgrößen

Admissible sash sizes

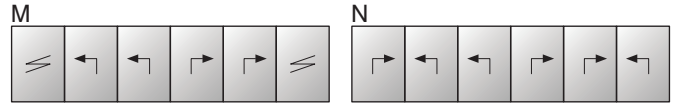

		1940037				1940037											
	(Pa)	400	800	1200	-	400	800	1200	-	-	-	-	-	-	-	-	-
	(Pa)	-	-	-	-	-	-	-	-	-	-	-	-	-	-	-	-
	max.	FAB (m)	3.2	3.2	3.2	-	3.2	3.2	3.2	-	-	-	-	-	-	-	-
		FAH (m)	2.8	2.4	2.2	-	2.8	2.4	2.2	-	-	-	-	-	-	-	-
	min.	FAB (m)	0.77	0.77	0.77	-	1.38	1.38	1.38	-	-	-	-	-	-	-	-
		FAH (m)	1.2	1.2	1.2	-	1.2	1.2	1.2	-	-	-	-	-	-	-	-
MV / MB	FAB (m)	-	-	-	-	-	-	-	-	-	-	-	-	-	-	-	-
	FAH (m)	-	-	-	-	-	-	-	-	-	-	-	-	-	-	-	-
	min.	FAB (m)	0.96	0.96	0.96	-	1.38	1.38	1.38	-	-	-	-	-	-	-	-
		FAH (m)	1.31	1.31	1.31	-	1.31	1.31	1.31	-	-	-	-	-	-	-	-
	min.	FAB (m)	-	-	-	-	-	-	-	-	-	-	-	-	-	-	-
		FAH (m)	-	-	-	-	-	-	-	-	-	-	-	-	-	-	-
	max. (kg)	300				400				-				-			

WICSLIDE 160

Beschlagsübersicht nach Schemas (PZ) Hardware survey for schemes (profile cylinder)



Schema A / Scheme A	Schema D / Scheme D	Schema C / Scheme C	Schema F / Scheme F	Schema G / Scheme G	Schema H / Scheme H	Schema G3 / Scheme G3	Schema H3 / Scheme H3	Schema I / Scheme I	Schema J / Scheme J	Schema K / Scheme K	Schema L / Scheme L	Schema M / Scheme M	Schema N / Scheme N
---------------------	---------------------	---------------------	---------------------	---------------------	---------------------	-----------------------	-----------------------	---------------------	---------------------	---------------------	---------------------	---------------------	---------------------

Artikel Article	Beschreibung Designation	Anzahl Quantity													
		Schema A / Scheme A	Schema D / Scheme D	Schema C / Scheme C	Schema F / Scheme F	Schema G / Scheme G	Schema H / Scheme H	Schema G3 / Scheme G3	Schema H3 / Scheme H3	Schema I / Scheme I	Schema J / Scheme J	Schema K / Scheme K	Schema L / Scheme L	Schema M / Scheme M	Schema N / Scheme N
6950012	Hebe-Schiebe Grundbeschlag HS 300 <i>Lifting sliding basic hardware HS 300</i>	1	2	2	4	1	3	2	3	3	5	3	5	4	6
6950061	Ergänzungssatz HS 400 <i>Extension set HS 400</i>	(1)	(2)	(2)	(4)	(1)	(3)	(2)	(3)	(3)	(5)	(3)	(5)	(4)	(6)
6950013 - 6950016	Getriebe mit Riegelbolzen (PZ) <i>Gear with catch bolt (PZ)</i>	1	2	1	3	-	2	1	2	-	2	1	3	1	3
6950169	Getriebeverlängerung mit Riegelbolzen <i>Gear extension with catch bolt</i>	(1)	(2)	(1)	(3)	-	-	-	-	-	-	-	-	-	-
6950021 - 6950024	Getriebe ohne Riegelbolzen (PZ) <i>Gear without catch bolt (PZ)</i>	-	-	1	1	-	-	-	-	-	-	1	1	1	1
6050326	Getriebeverlängerung ohne Riegelbolzen <i>Gear extension without catch bolt</i>	-	-	(1)	(1)	-	-	-	-	-	-	-	-	-	-
6950029 - 6950032	Getriebe mit Verriegelung nach oben (PZ) <i>Gear with locking towards the top (PZ)</i>	-	-	-	-	1	1	1	1	3	3	1	1	2	2
6950038 - 6950041 6950044, 6950051	Griff-Garnitur (PZ) <i>Handle set (PZ)</i>	1	2	2	4	1	3	2	3	3	5	3	5	4	6
6920071, 6920241	Profilzylinder <i>Profile cylinder</i>	1	2	2	4	1	3	2	3	3	5	3	5	4	6
6950047, 6950049, 6950170	Vierkant-Stift 10 mm <i>Square pin 10 mm</i>	1	2	2	4	1	3	2	3	3	5	3	5	4	6
6950054 - 6950057	Verbindungsstange <i>Connection rod</i>	1	2	2	4	1	3	2	3	3	5	3	5	4	6
6950060	Zusatzverriegelung <i>Additional locking point</i>	(1)	(2)	(1)	(3)	-	-	-	-	-	-	-	-	-	-
6950058	Flügelanschlag <i>Sash stop</i>	2	4	4	4	2	2	4	6	6	8	6	6	8	8
6000005	Befestigungsgarnitur <i>Top fixing set</i>	-	-	-	-	1	1	1	1	3	3	1	1	2	2
6000006	Unterlegplatte <i>Support plate</i>	(2)	-	(4)	-	(2)	-	(2)	-	(2)	-	(2)	-	(4)	-
6950300	EH Ergänzungssatz <i>Extension set burglary resistance</i>	(1)	(2)	-	-	-	-	-	-	-	-	-	-	-	-
6051032, 6051033	Zugstange <i>Operation rod</i>	(1)	(2)	-	-	-	-	-	-	-	-	-	-	-	-
6950059	Riegelbolzen <i>Bottom locking</i>	(1)	(2)	2	2	-	-	-	-	-	-	2	2	2	2

WICSLIDE 160

Beschläge Hardware

Beschlagsübersicht nach Schemas (RZ) Hardware survey for schemes (round cylinder)



Artikel Article	Beschreibung Designation	Anzahl Quantity													
		Schema A / Scheme A	Schema D / Scheme D	Schema C / Scheme C	Schema F / Scheme F	Schema G / Scheme G	Schema H / Scheme H	Schema G3 / Scheme G3	Schema H3 / Scheme H3	Schema I / Scheme I	Schema J / Scheme J	Schema K / Scheme K	Schema L / Scheme L	Schema M / Scheme M	Schema N / Scheme N
6950012	Hebe-Schiebe Grundbeschlag HS 300 <i>Lifting sliding basic hardware HS 300</i>	1	2	2	4	1	3	2	3	3	5	3	5	4	6
6950061	Ergänzungssatz HS 400 <i>Extension set HS 400</i>	(1)	(2)	(2)	(4)	(1)	(3)	(2)	(3)	(3)	(5)	(3)	(5)	(4)	(6)
6950017 - 6950020	Getriebe mit Riegelbolzen (RZ) <i>Gear with catch bolt (RZ)</i>	1	2	1	3	-	2	1	2	-	2	1	3	1	3
6950169	Getriebeverlängerung mit Riegelbolzen <i>Gear extension with catch bolt</i>	(1)	(2)	(1)	(3)	-	-	-	-	-	-	-	-	-	-
6950025 - 6950028	Getriebe ohne Riegelbolzen (RZ) <i>Gear without catch bolt (RZ)</i>	-	-	1	1	-	-	-	-	-	-	1	1	1	1
6050326	Getriebeverlängerung ohne Riegelbolzen <i>Gear extension without catch bolt</i>	-	-	(1)	(1)	-	-	-	-	-	-	-	-	-	-
6950033 - 6950036	Getriebe mit Verriegelung nach oben (RZ) <i>Gear with locking towards the top (RZ)</i>	-	-	-	-	1	1	1	1	3	3	1	1	2	2
6950038, 6950039, 6950042, 6950043, 6950045, 6950051	Griff-Garnitur (RZ) <i>Handle set (RZ)</i>	1	2	2	4	1	3	2	3	3	5	3	5	4	6
6950047, 6950049, 6950170	Vierkant-Stift 10 mm <i>Square pin 10 mm</i>	1	2	2	4	1	3	2	3	3	5	3	5	4	6
6950054 - 6950057	Verbindungsstange <i>Connection rod</i>	1	2	2	4	1	3	2	3	3	5	3	5	4	6
6950060	Zusatzverriegelung <i>Additional locking point</i>	(1)	(2)	(1)	(3)	-	-	-	-	-	-	-	-	-	-
6950058	Flügelanschlag <i>Sash stop</i>	2	4	4	4	2	2	4	6	6	8	6	6	8	8
6000005	Befestigungsgarnitur <i>Top fixing set</i>	-	-	-	-	1	1	1	1	3	3	1	1	2	2
6000006	Unterlegplatte <i>Support plate</i>	(2)	-	(4)	-	(2)	-	(2)	-	(2)	-	(2)	-	(4)	-
6950300	EH Ergänzungssatz <i>Extension set burglary resistance</i>	(1)	(2)	-	-	-	-	-	-	-	-	-	-	-	-
6051032, 6051033	Zugstange <i>Operation rod</i>	(1)	(2)	-	-	-	-	-	-	-	-	-	-	-	-
6950059	Riegelbolzen <i>Bottom locking</i>	(1)	(2)	2	2	-	-	-	-	-	-	2	2	2	2

WICSLIDE 160

Beschlagsbedarf EH nach Schemas
Hardware requirements for schemes

Beschläge
Hardware



Schema A / Scheme A
Schema D / Scheme D
Schema C / Scheme C
Schema F / Scheme F
Schema G / Scheme G
Schema H / Scheme H
Schema G3 / Scheme G3
Schema H3 / Scheme H3
Schema I / Scheme I
Schema J / Scheme J
Schema K / Scheme K
Schema L / Scheme L
Schema M / Scheme M
Schema N / Scheme N

Artikel Article	Beschreibung Designation	Anzahl Quantity													
		Schema A	Schema D	Schema C	Schema F	Schema G	Schema H	Schema G3	Schema H3	Schema I	Schema J	Schema K	Schema L	Schema M	Schema N
6950300	EH Ergänzungssatz Extension set burglary resistance	1	2	2	4	-	2	1	2	-	2	2	4	2	4
6051032 6051033	Zugstange Operation rod	1	2	2	4	-	2	1	2	-	2	2	4	2	4
6950059	Riegelbock Bottom locking	1	2	2	2	-	2	1	2	-	2	2	2	2	2
6000010	EH Verriegelungsgarnitur Locking set burglary resistance	-	-	-	-	1	1	-	-	2	2	-	-	-	-
6000011	EH Befestigungsgarnitur Fixing set burglary resistance	-	3	2	8	-	6	-	3	-	6	2	5	2	8
6000012	EH Befestigungsgarnitur (Stulp) Fixing set burglary resistance (meeting stiles)	-	-	2	2	-	-	-	-	-	-	2	2	2	2

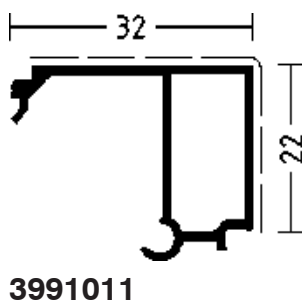
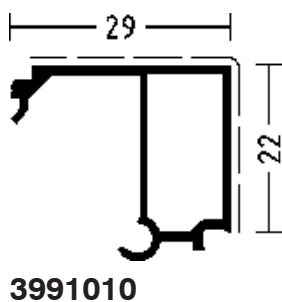
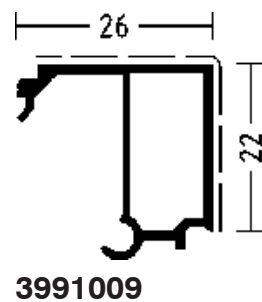
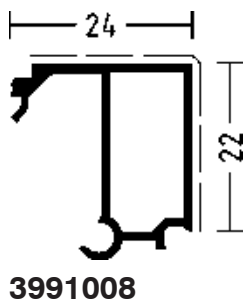
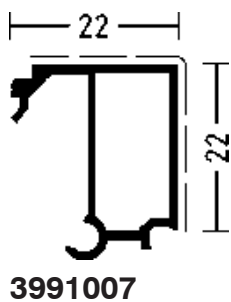
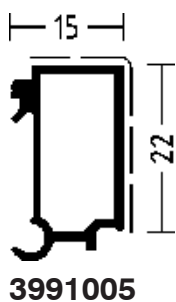
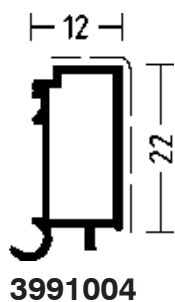
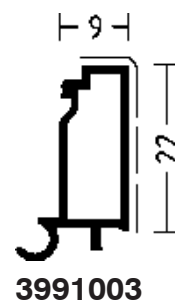
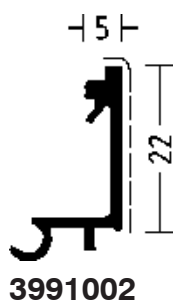
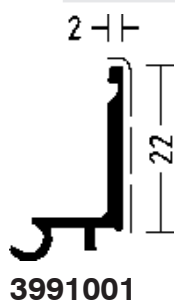

	Seite <i>Page</i>
Glasleistenprofile <i>Glazing bead profiles</i>	3/3
Fenstersims <i>Window sill</i>	3/7
Verschiedenes <i>Miscellaneous</i>	3/8
Laibungsprofil <i>Flashing</i>	3/9
Abdeckleiste <i>Cover strip</i>	3/11
Zusatzprofile <i>Additional profiles</i>	3/12
Eckwinkelprofile <i>Corner angle profiles</i>	3/15

	 m	 mm	 mm
3991001	6,5	89	22
3991002	6,5	100	22
3991003	6,5	90	28
3991004	6,5	92	31
3991005	6,5	95	34
3991006	6,5	110	38
3991007	6,5	116	41
3991008	6,5	120	43
3991009	6,5	124	45
3991010	6,5	130	48
3991011	6,5	136	51



WICSLIDE 160

Glasleistenprofile
Glazing bead profiles

	 m	 mm	 mm
3991012	6,5	140	53
3991013	6,5	146	56
3991014	6,5	154	60
3991015	6,5	162	64

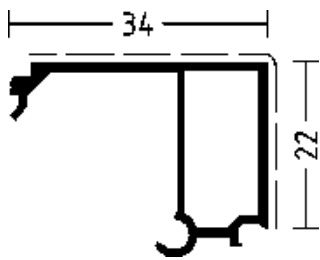

3991012

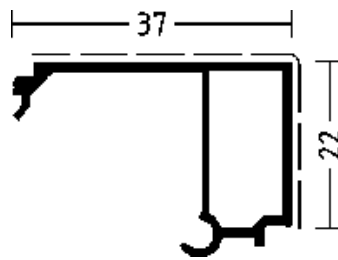

3991013

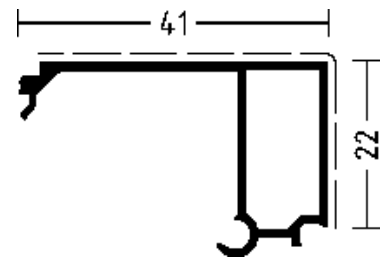

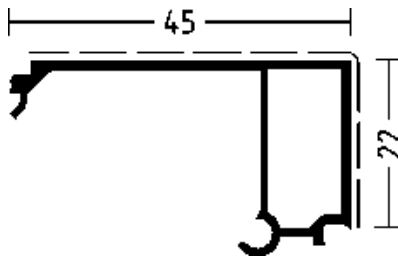

3991014



3991015

WICSLIDE 160

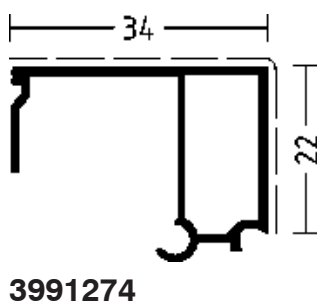
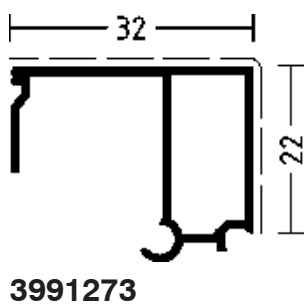
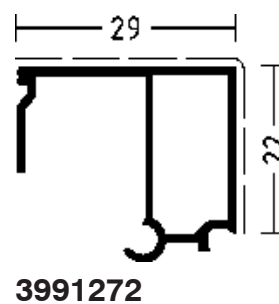
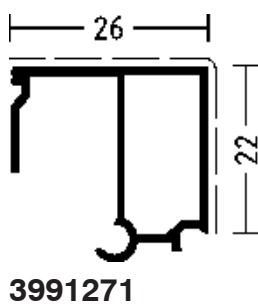
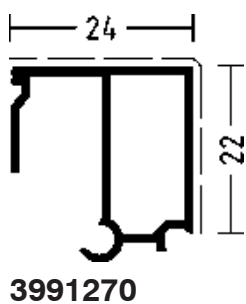
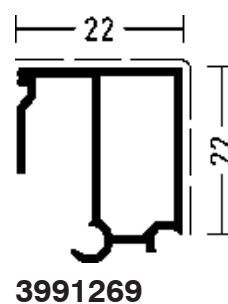
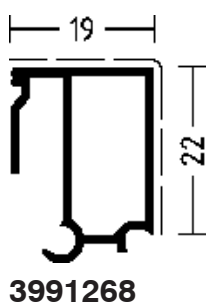
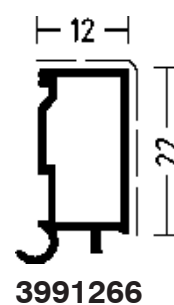
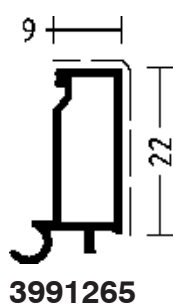
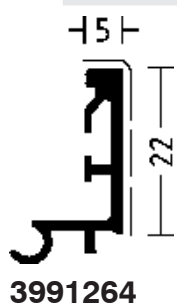

Glasleistenprofile
Glazing bead profiles

	 m	 mm	 mm
3991264	6,5	116	27
3991265	6,5	90	31
3991266	6,5	92	34
3991267	6,5	92	37
3991268	6,5	124	41
3991269	6,5	130	44
3991270	6,5	134	46
3991271	6,5	138	48
3991272	6,5	144	51
3991273	6,5	150	54
3991274	6,5	154	56



WICSLIDE 160

Glasleistenprofile
Glazing bead profiles

	 m	 mm	 mm
3991275	6,5	160	59
3991276	6,5	164	63
3991277	6,5	172	67

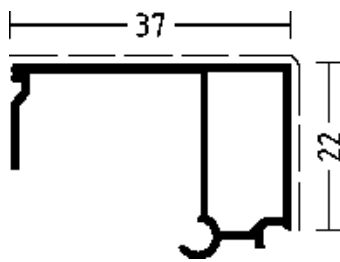

3991275

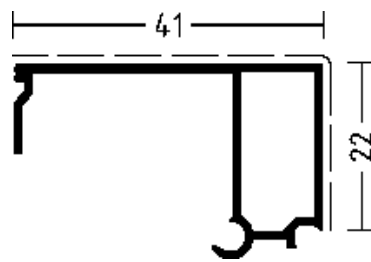

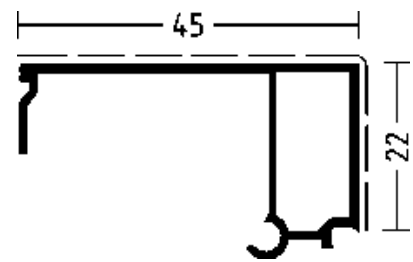

3991276



3991277

WICSLIDE 160

Fenstersims
Window sill

	 m	 mm	 mm
3090161	6,5	171	61
3090162	6,5	292	121
4000170	6,5	338	141

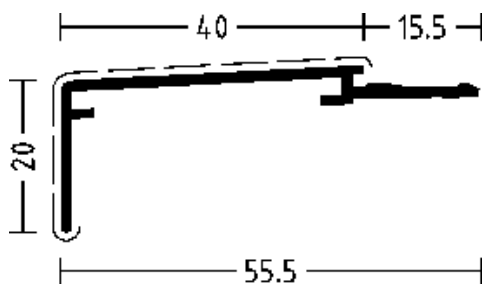

3090161

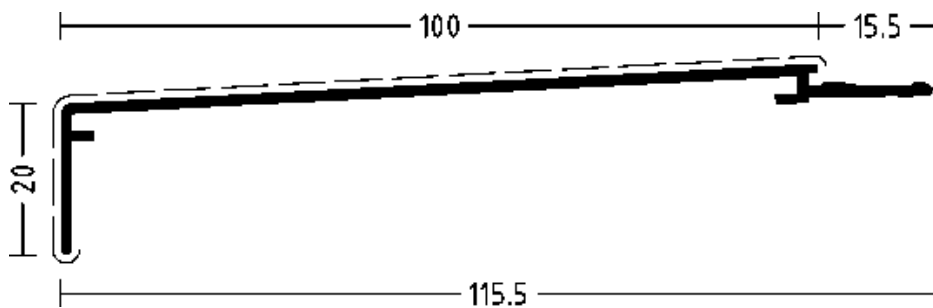

3090162

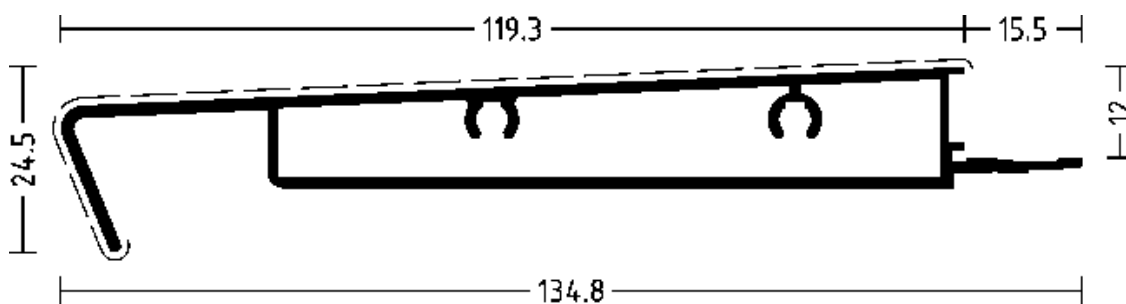



4000170

Vorgebohrtes Profil, Endstücke 4040456
Pre-drilled profile, end plug 4040456

WICSLIDE 160

Verschiedenes
Miscellaneous

	 m	 mm	 mm
3090063	6,5	530	16
3690844	6	46	46

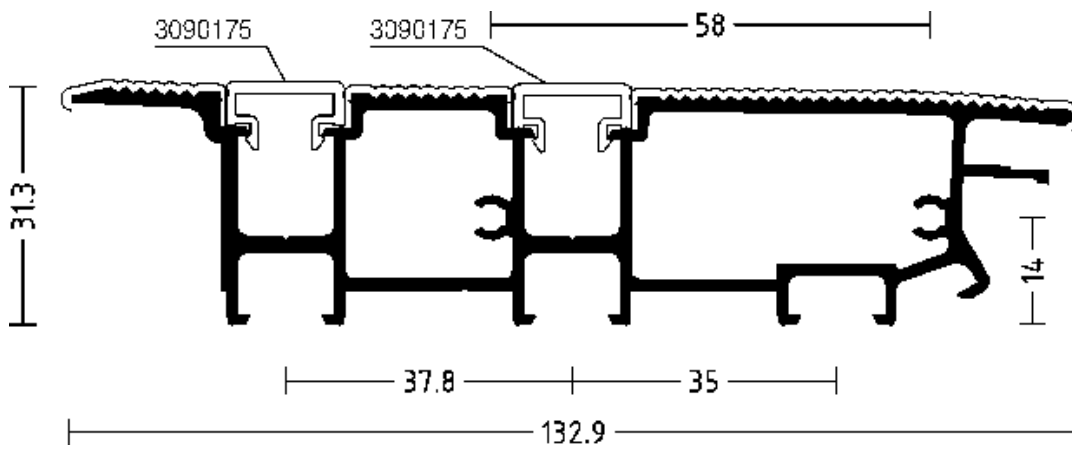

3090063

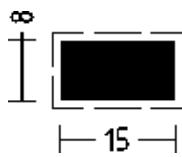

Barrierefreie Schwelle
Barrier free threshold



3690844

WICSLIDE 160

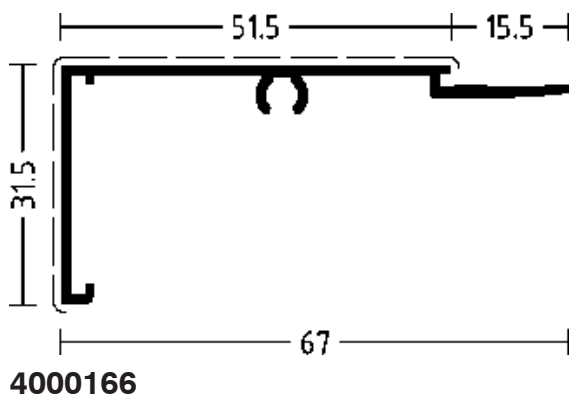
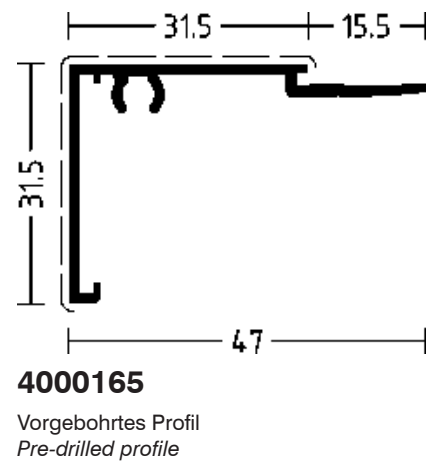
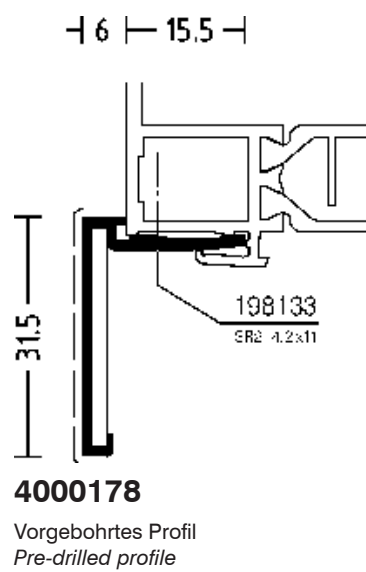

Laibungsprofil Flashing

	 m	 mm	 mm
3090120	6,5	96	30
4000178	6,5	121	32
4000165	6,5	194	63
4000166	6,5	234	83



WICSLIDE 160

Laibungsprofil
Flashing

	 m	 mm	 mm
4000167	6,5	274	103
4000168	6,5	314	123

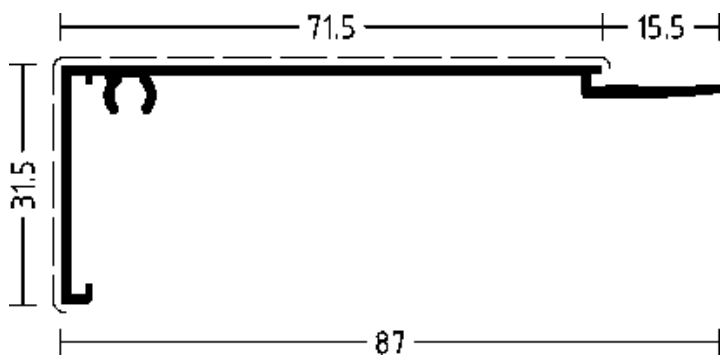

4000167

Vorgebohrtes Profil
Pre-drilled profile

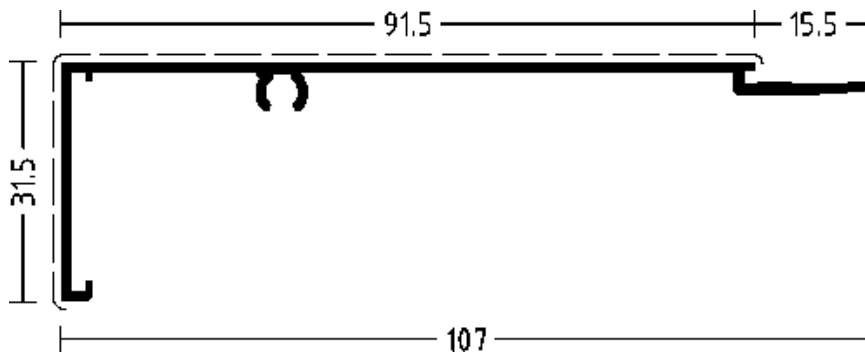



4000168

Vorgebohrtes Profil
Pre-drilled profile

WICSLIDE 160

Abdeckleiste
Cover strip

	 m	 mm	 mm
3090121	6,5	88	31
3090122	6,5	128	51
3090123	6,5	198	86

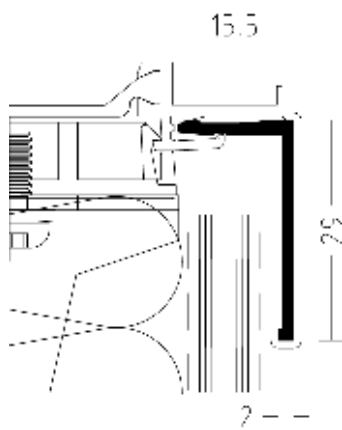

3090121





3090122



3090123

WICSLIDE 160

Zusatzprofile
Additional profiles

	 m	 mm	 mm
3091059	6	138	30
3090193	6	140	47
3091058	6	352	147
3090194	6	289	159

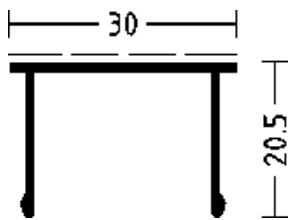

3091059

Abdeckprofil für Verstärkung 3091058
Cover profile for reinforcement 3091058

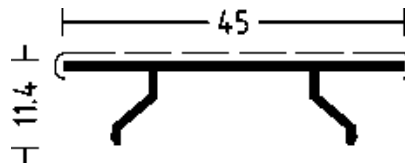

3090193

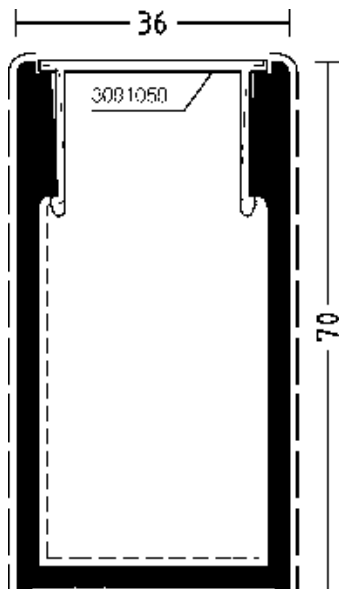

Abdeckprofil für Verstärkung 3090194
Cover profile for reinforcement 3090194

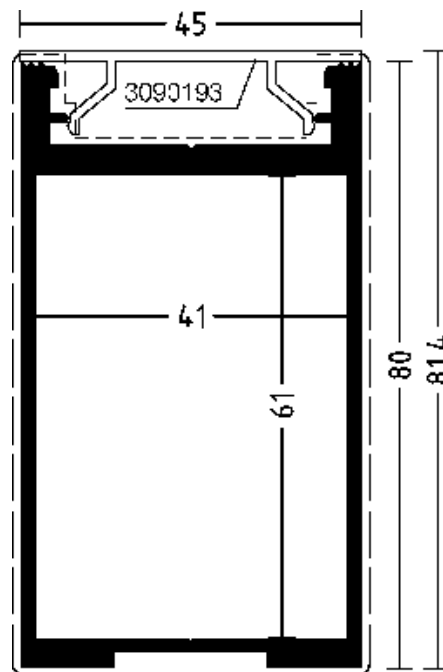

3091058



3090194

	 m	 mm	 mm
3041173	6	94	30
3041229	6,5	105	16
3041310	6,5	110	16
3041313	5,5	101	11
3041309	5,5	187	72
3940009	5,5	264	83
3940010	5,5	353	169

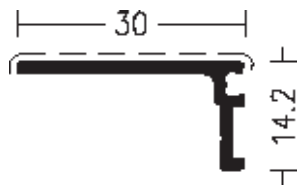

3041173

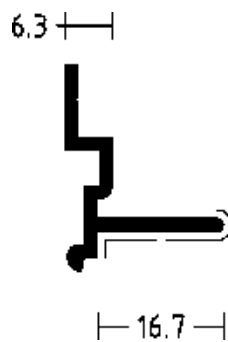

3041229

Zusatzprofil für Dehnstoß
Additional profile for expansion joint

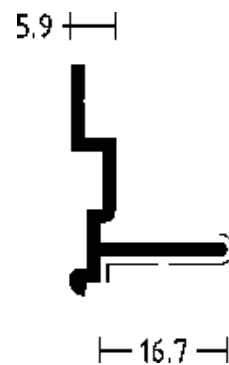

3041310

Zusatzprofil für Dehnstoß, Festverglasung
Additional profile for expansion joint, fixed glazing

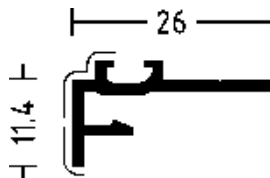

3041313

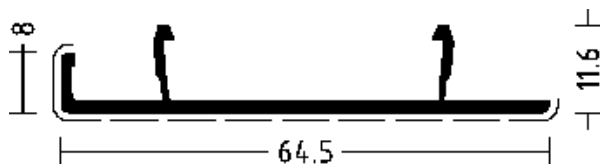

3041309

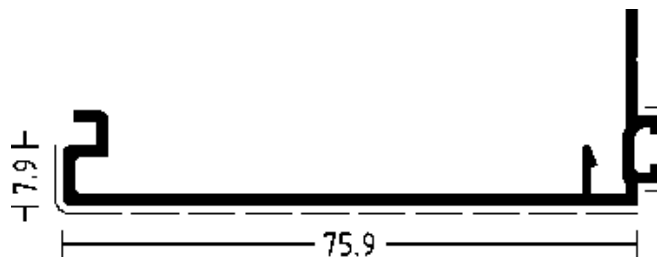

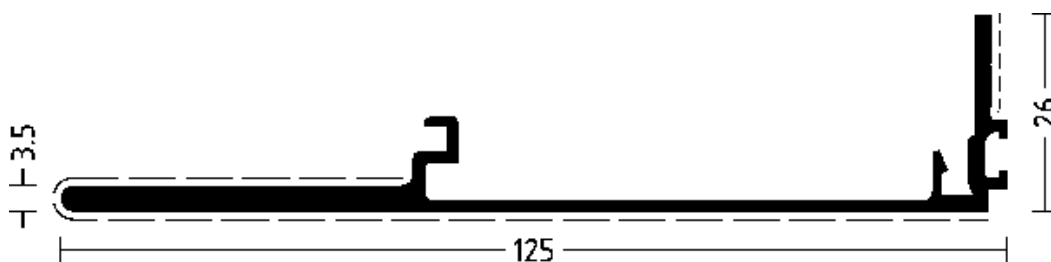

3940009



3940010

WICSLIDE 160

Zusatzprofile
Additional profiles

	 m	 mm	 mm
3041329	6,5	90	0
3041330	6,5	90	0
3940020	6,5	132	14
3940021	6,5	108	8
3940022	6,5	105	27
3090175	6,5	75	25.4

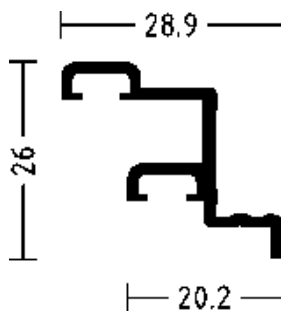

3041329

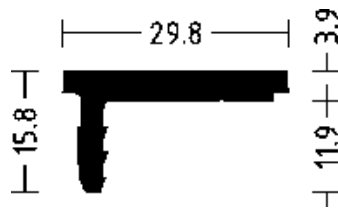

3041330

für Kunststoff-Dämmlagen
for thermal break profiles



3940021

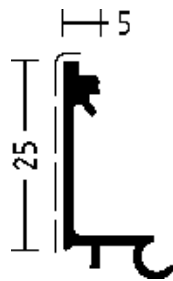

3940022

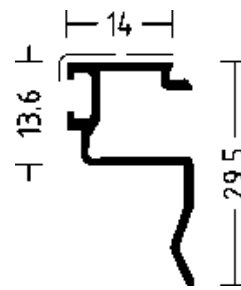

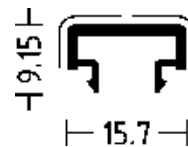

3940020



3090175

WICSLIDE 160

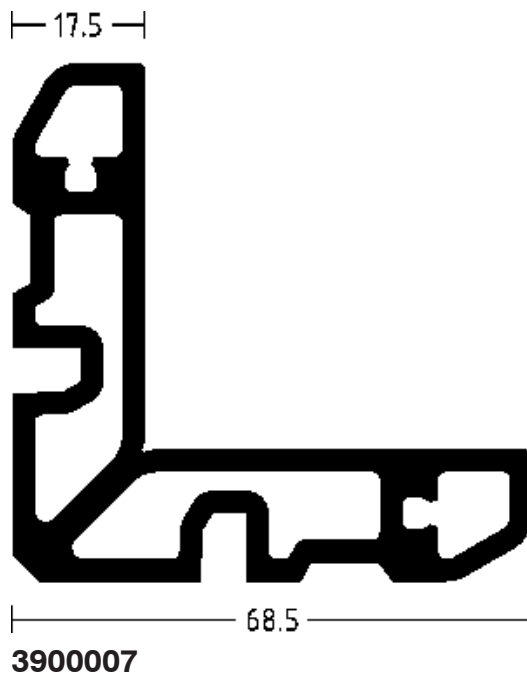
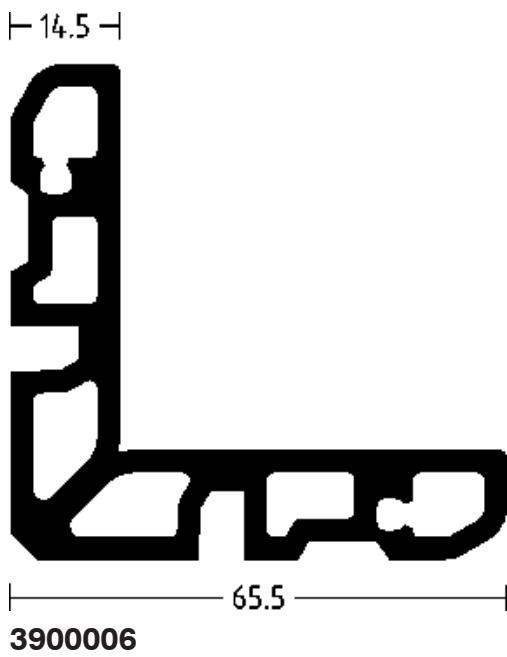

Eckwinkelprofile
Corner angle profiles

	 m	 mm	 mm
3900006	3	291	0
3900007	3	300	0



WICSLIDE 160

Eckwinkelprofile
Corner angle profiles

			
	m	mm	mm
3900012	3	383	0

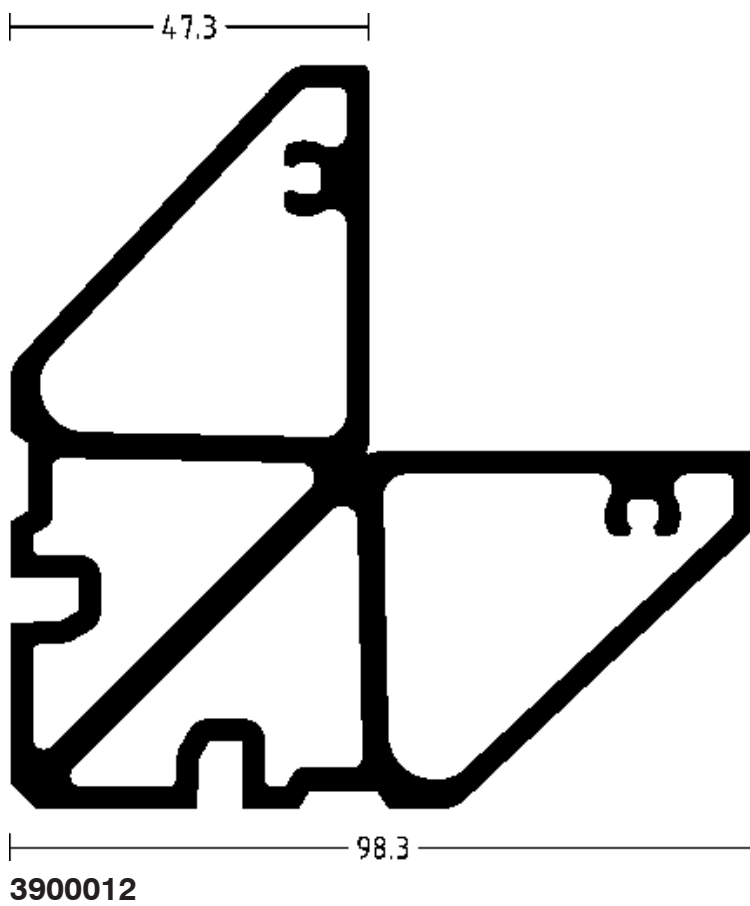

	Seite <i>Page</i>
Übersicht Zubehör <i>Survey of accessories</i>	4/3
Dichtungen Meterware <i>Gaskets metre ware</i>	4/11
Dichtungen Stückware <i>Gaskets single parts</i>	4/15
Kunststoffprofile, Formstücke <i>Plastic profiles, moulded pieces</i>	4/17
Eckwinkel, Blechteile <i>Corner angles, metal sheet parts</i>	4/24
Verbinder <i>Butt-joint connectors</i>	4/26
Verbindungselemente / Schrauben <i>Connecting components / screws</i>	4/28
Verschiedenes <i>Miscellaneous</i>	4/30
Schrauben-Tabellen <i>Screw tables</i>	4/33

WICSLIDE 160

Technische Information
Technical information

Übersicht Zubehör
Survey of accessories



4910004



4010003



4010015



4010016

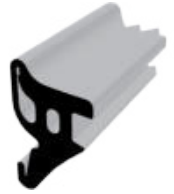

4010017

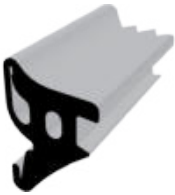

4010018



4010443



4910021

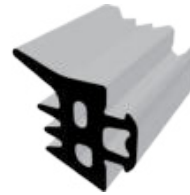

4910022

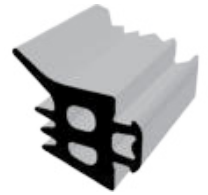

4910023

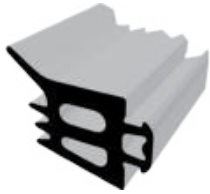

4910024



4910032



4910084



4910100



J0013



4990003



4990009

WICSLIDE 160

Technische Information
Technical information

Übersicht Zubehör
Survey of accessories



4020006



4020639

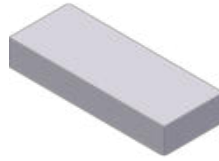

4920002



4920003

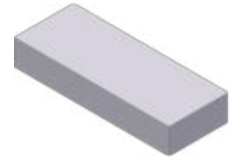

4920012



4920013

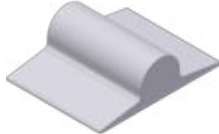

4920094

WICSLIDE 160

Technische Information
Technical information

Übersicht Zubehör
Survey of accessories

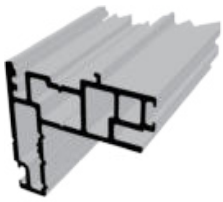

4030382

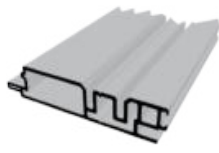

4030383



4020049

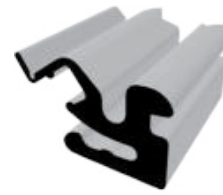

4030035



4030302



4030305

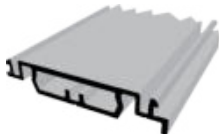

4030334



4930019

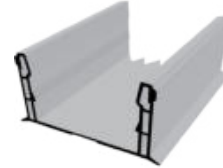

4930025



4930028



4930029



4930033



4930035



4930091



4040610



4040086



4070030



4040456



4040678



4040700



4940077



4940088



4940114



4940116



4940117

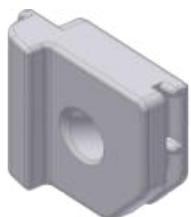

4940166



4940170



8030015



4940187

WICSLIDE 160

Technische Information
Technical information

Übersicht Zubehör
Survey of accessories



4040085



4940535

WICSLIDE 160

Technische Information
Technical information

Übersicht Zubehör
Survey of accessories



4950008



4050150



4050153

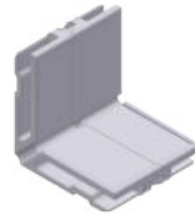

4950092



4950095



4950096



4950099

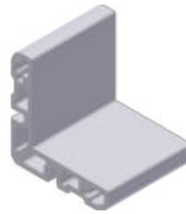

4950239

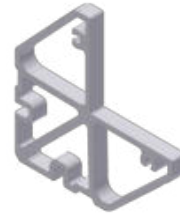

4950264

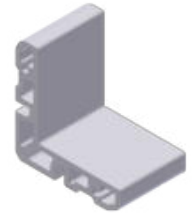

4950266

WICSLIDE 160

Technische Information
Technical information

Übersicht Zubehör
Survey of accessories

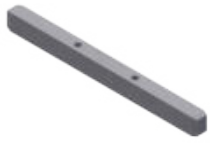

4060377



4060386



4060388



4960002



4960004



4960009



4960026

WICSLIDE 160

Technische Information
Technical information

Übersicht Zubehör
Survey of accessories



198059



4070000



4070002



4070008



4070010



4070011



4070012



4970722

WICSLIDE 160

Technische Information
Technical information

Übersicht Zubehör
Survey of accessories



4080452



4080454



4000207



4080318



4080350



4080367



4900073

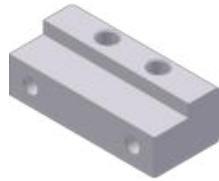

4980064



4980065

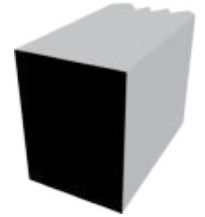

4990005

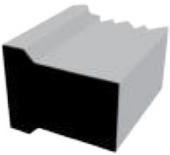

4990012



4990013







4990018

WICSLIDE 160

Dichtungen Meterware

Gaskets metre ware

Zubehör
Accessories



Artikel Article	VE PU	Anwendung Application	Bezeichnung / Hinweise Designation / Indications	Abbildung Figure
		Material / Material Farbe / Colour	Zuordnung Assignment	
4910004	200 m 200 m	WICSLIDE 160	Dichtung Verglasungsdichtung innen. Spalt 4 mm. Dichtung umlaufend, Stoß oben horizontal.	
		EPDM	Glazing Inner glazing gasket. Gap 4 mm.	
		schwarz black	Perimetric gasket, butt joint top horizontal.	
4010003	200 m 200 m	WICSLIDE 160	Verglasungsdichtung Verglasungsdichtung außen. Spalt 4 mm. Dichtung umlaufend. Stoß oben horizontal.	
		EPDM, geschäumt EPDM, foamed	External glazing gasket Outer glazing gasket. Gap 4 mm.	
		schwarz black	Perimetric gasket. Butt joint top horizontal.	
4010015	200 m 200 m	WICSLIDE 160	Dichtung Verglasungsdichtung innen. Spalt 5 mm. Dichtung umlaufend. Stoß oben horizontal. Kennzeichen 2 x blau.	
		EPDM	Gasket Inner glazing gasket. Gap 5 mm.	
		schwarz black	Perimetric gasket. Butt joint top horizontal. Marked with 2 x blue.	
4010016	200 m 200 m	WICSLIDE 160	Dichtung Verglasungsdichtung innen. Spalt 6 mm. Dichtung umlaufend. Stoß oben horizontal. Kennzeichen 2 x rot.	
		EPDM	Gasket Inner glazing gasket. Gap 6 mm.	
		schwarz black	Perimetric gasket. Butt joint top horizontal. Marked with 2 x red.	

WICSLIDE 160

Dichtungen Meterware

Gaskets metre ware

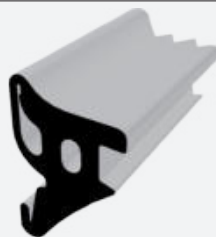
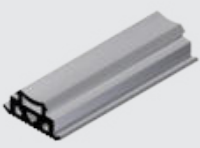
Zubehör
Accessories



Artikel Article	VE PU	Anwendung Application	Bezeichnung / Hinweise Designation / Indications	Abbildung Figure
		Material / Material Farbe / Colour	Zuordnung Assignment	
4010017	200 m 200 m	WICSLIDE 160	Dichtung Verglasungsdichtung innen. Spalt 7 mm. Dichtung umlaufend. Stoß oben horizontal. Kennzeichen 2 x grün.	
		EPDM	Gasket Inner glazing gasket. Gap 7 mm.	
		schwarz black	Perimetric gasket. Butt joint top horizontal. Marked with 2 x green.	
4010018	200 m 200 m	WICSLIDE 160	Dichtung Verglasungsdichtung innen. Spalt 8 mm. Dichtung umlaufend. Stoß oben horizontal. Kennzeichen 2 x weiß.	
		EPDM	Gasket Inner glazing gasket. Gap 8 mm.	
		schwarz black	Perimetric gasket. Butt joint top horizontal. Marked with 2x white.	
4010443	50 m 50 m	WICSLIDE 160	Tragdichtung für barrierefreie Schwelle Verwendung mit Profil 3090163 (barrierefrei)	
		EPDM	Support and cover gasket for barrier-free threshold	
		schwarz black	Used with profile 3090163	
4910021	100 m 100 m	WICSLIDE 160	Verglasungsdichtung Verglasungsdichtung innen. Spalt 4.5 mm. (gleitpolymerisiert) Bei verdecktliegenden Flügeln einsetzbar. Rahmenvulkanisation mit 4910059 möglich.	
		EPDM	Glazing gasket Inner glazing gasket. Gap 4.5 mm. (glide polymerized)	
		schwarz black	Applicable in concealed sashes. Gasket frame vulcanization possible with 4910059.	

WICSLIDE 160

Dichtungen Meterware

Gaskets metre ware

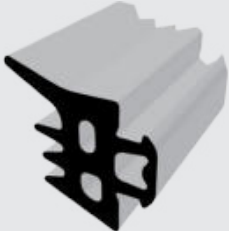
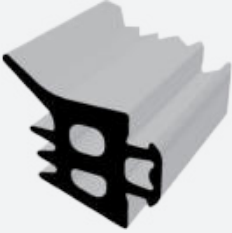
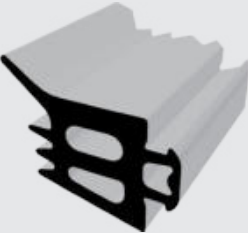

Zubehör
Accessories

Artikel Article	VE PU	Anwendung Application	Bezeichnung / Hinweise Designation / Indications	Abbildung Figure
		Material / Material Farbe / Colour	Zuordnung Assignment	
4910022	100 m 100 m	WICSLIDE 160	Verglasungsdichtung Verglasungsdichtung. Spalt 6.5 mm. (gleitpolymerisiert) Rahmenvulkanisation mit 4910060 möglich.	
		EPDM	Glazing gasket Glazing gasket. Gap 6.5 mm. (glide polymerized)	
		schwarz black	Gasket frame vulcanization possible with 4910060.	
4910023	100 m 100 m	WICSLIDE 160	Verglasungsdichtung Verglasungsdichtung. Spalt 8.5 mm. (gleitpolymerisiert). Bei verdecktliegenden Flügeln einsetzbar. Rahmenvulkanisation mit 4910061 möglich.	
		EPDM	Glazing gasket Glazing gasket. Gap 8.5 mm. (glide polymerized).	
		schwarz black	Applicable in concealed sashes. Gasket frame vulcanization possible with 4910061.	
4910024	100 m 100 m	WICSLIDE 160	Verglasungsdichtung Verglasungsdichtung innen. Spalt 10.5 mm. (gleitpolymerisiert) Bei verdecktliegenden Flügeln einsetzbar. Rahmenvulkanisation mit 4910062 möglich.	
		EPDM	Glazing gasket Inner glazing gasket. Gap 10.5 mm. (glide polymerized)	
		schwarz black	Applicable in concealed sashes. Gasket frame vulcanization possible with 4910062.	
4910032	100 m 100 m	WICSLIDE 160	Hebe-Schiebe-Dichtung	
		TPE	Lifting-Sliding gasket	
		grau grey schwarz black		

WICSLIDE 160

Dichtungen Meterware
Gaskets metre ware

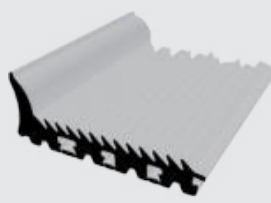
Zubehör
Accessories

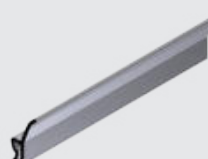
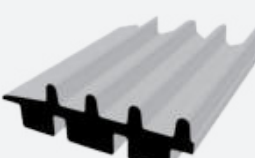
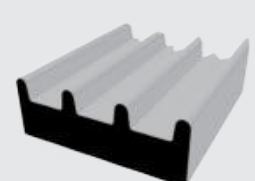
Artikel Article	VE PU	Anwendung Application	Bezeichnung / Hinweise Designation / Indications	Abbildung Figure
		Material / Material Farbe / Colour	Zuordnung Assignment	
4910084	20 m 20 m	WICSLIDE 160	Füllungssicherung Zuschnitt 100 mm	
		EPDM	Infill safeguard Cutting 100 mm	
		schwarz black	1940037	
4910100	100 m 100 m	WICSLIDE 160	Bürstendichtung Verwendung: in Verhakungszone	
			Weather strip Application: in hooking zone	
		grau grey schwarz black		
J0013	200 m 200 m	WICSLIDE 160	Regen-Abweisdichtung Verwendung mit Profil 3090163 (barrierefrei)	
			Rain-proofing gasket	
		schwarz black		
4990003	100 m 100 m	WICSLIDE 160	Spezial-Dämmprofil Verwendung in Blendrahmen- und Kämpferprofilen. Bautiefe 65, 75 und 95 mm. Umlaufend mit Unterbrechungen an Glasklötzen, Ecken und Entwässerung. Ausnehmungen für die Glasfalzbelüftung vornehmen!	
		PE, geschäumt PE, foamed	Special insulation profile Application in frame and transom profiles. Construction depth: 65, 75 and 95 mm. Circumferential with cut-outs in area of glazing shims, corners and drainage areas. Make cut-outs for rebate ventilation!	
		grau grey		
4990009	100 m 100 m	WICSLIDE 160	Spezial-Dämmprofil Verwendung: Umlaufend mit Unterbrechungen an Glasklötzen, Ecken und Entwässerung.	
		PE, geschäumt PE, foamed	Special insulation profile Application: all around with cut-outs in area of glazing shims, corners and drainage areas.	
		grau grey		

WICSLIDE 160

Dichtungen Stückware
Gaskets single parts

Zubehör
Accessories

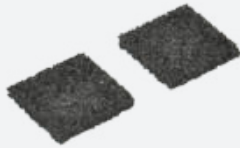
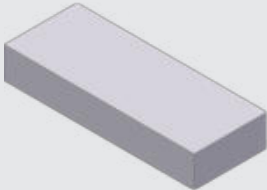
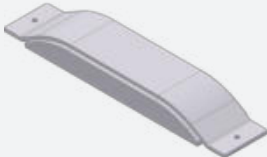
Artikel Article	VE PU	Anwendung Application	Bezeichnung / Hinweise Designation / Indications	Abbildung Figure
		Material / Material Farbe / Colour	Zuordnung Assignment	
4020006	100 St. 100 pcs	WICSLIDE 160	Federstück Bei pulverbeschichteten Glasleistenprofilen. Federstücke 15 mm lang. Als Montagehilfe jeweils an den Enden der Glasleisten und mittig einlegen. Anwendung ab 15 mm Glasleistenbreite.	
		EPDM	Spring piece <i>For powder coated glazing beads. Length of spring piece 15 mm. Insert spring pieces at the respective ends of glazing beads and in the centre as assembly help.</i>	
		schwarz black	<i>Application above 15 mm glazing bead width.</i>	
4020639	1 Garn. 1 set	WICSLIDE 160	Garnitur Dichtteil Auf Abschlussteil kleben	
		EPDM, geschäumt EPDM, foamed	Set sealing part <i>Glue on end piece</i>	
			4040678	
4920002	10 St. 10 pcs	WICSLIDE 160	Dichtbrücke, unten	
		EPDM, geschäumt EPDM, foamed	Gasket bridge, bottom	
4920003	1 St. 1 pcs	WICSLIDE 160	Dichtbrücke, oben	
			Gasket bridge, top	
4920012	10 St. 10 pcs	WICSLIDE 160	Dichtbrücke unten	
		EPDM, geschäumt EPDM, foamed	Gasket bridge bottom	
		schwarz black		

WICSLIDE 160

Dichtungen Stückware
Gaskets single parts

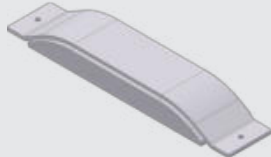
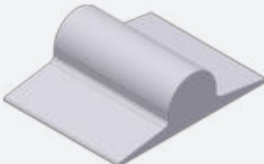

Zubehör
Accessories

Artikel Article	VE PU	Anwendung Application	Bezeichnung / Hinweise Designation / Indications	Abbildung Figure
		Material / Material Farbe / Colour	Zuordnung Assignment	
4920013	1 St. 1 pcs	WICSLIDE 160	Dichtbrücke, oben	
			Gasket bridge, top	
		schwarz black		
4920094	20 St. 20 pcs	WICSLIDE 160	Dichtstück Verwendung: In Dichtteil 4940109 und 4940117 bei Verwendung von Abdeckprofil 3940019.	
		EPDM	Sealing part Application: In sealing parts 4940109 and 4940117 when using cover profile 3940019.	
		schwarz black		

WICSLIDE 160

Kunststoffprofile, Formstücke
Plastic profiles, moulded pieces

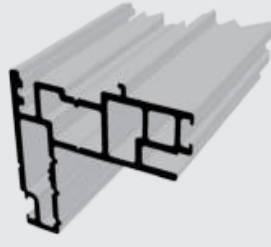
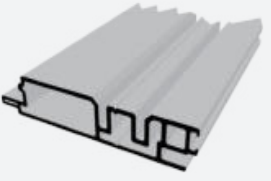



Zubehör
Accessories

Artikel Article	VE PU	Anwendung Application	Bezeichnung / Hinweise Designation / Indications	Abbildung Figure
		Material / Material Farbe / Colour	Zuordnung Assignment	
4030382	6,5 m 6,5 m	WICSLIDE 160	Kunststoff-Dämmauflage	
		Kunststoff Plastic	Thermal break profile	
4030383	6,5 m 6,5 m	WICSLIDE 160	Kunststoff-Dämmauflage	
		Kunststoff Plastic	Thermal break profile	
4020049	100 St. 100 pcs	WICSLIDE 160	Federstück Bei eloxierten Glasleistenprofilen. Federstücke 15 mm lang. Als Montagehilfe ca. 50 mm von den Glasleistenenden und jede weitere Abstände 250 - 300 mm. Anwendung ab 15 mm Glasleistenbreiten.	
		PA	Spring piece For anodized glazing beads.	
		schwarz black	Length of spring piece 15 mm. Insert spring pieces approx. 50 mm from the respective ends of glazing beads as assembly help and every further distances of 250 - 300 mm. Application above 15 mm glazing bead width.	
4030035	4 m 4 m	WICSLIDE 160	Federprofil Verwendung: Glasleistennut für Außen- und Innenanwendung. Lieferung mit vormontierter Dichtung.	
		ABS	Spring profile Application: Glazing bead retaining groove.	
		schwarz black	For external and internal use. Delivery with pre-assembled gasket.	

WICSLIDE 160

Kunststoffprofile, Formstücke
Plastic profiles, moulded pieces

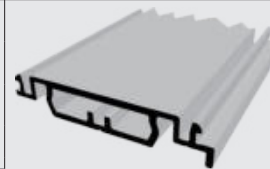

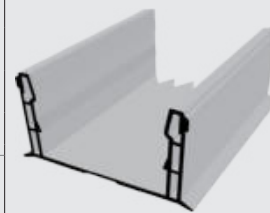

Zubehör
Accessories

Artikel Article	VE PU	Anwendung Application	Bezeichnung / Hinweise Designation / Indications	Abbildung Figure
		Material / Material Farbe / Colour	Zuordnung Assignment	
4030302	5,5 m 5,5 m	WICSLIDE 160	Aufsatzprofil Mittelstoß	
		PA	Supplementary profile Middle abutment	
		schwarz black	1940037,4040678	
4030305	6,5 m 6,5 m	WICSLIDE 160	Glasleiste Anwendung: Hochwärmedämmend. Nur im Außenflügel, senkrecht auf der Verhakungsseite. Zusammen mit Glasleiste 3991001 verwenden.	
		PA	Glazing bead Application: High thermal insulation. Only in exterior sash, vertical, on the side of the hooking zone. Use together with glazing bead 3991001.	
		schwarz black		
4030334	5,5 m 5,5 m	WICSLIDE 160	Aufsatzprofil Verhakungszone Typ 2	
		PA	Mounting profile Hooking zone type 2	
		schwarz black		
4930019	6,5 m 6,5 m	WICSLIDE 160	Einschubprofil	
		Kunststoff Plastic	Insertion profile	
		schwarz black		
4930025	6,5 m 6,5 m	WICSLIDE 160	Wasserrinnenprofil	
		Kunststoff Plastic	Gutter profile	
		schwarz black	1041344,1041345,1041346,1041347	

WICSLIDE 160

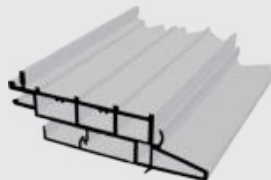
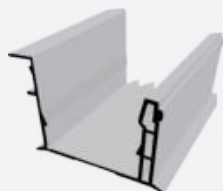
Kunststoffprofile, Formstücke
Plastic profiles, moulded pieces

Zubehör
Accessories

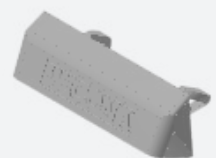
Artikel Article	VE PU	Anwendung Application	Bezeichnung / Hinweise Designation / Indications	Abbildung Figure
		Material / Material Farbe / Colour	Zuordnung Assignment	
4930028	5,5 m 5,5 m	WICSLIDE 160	Verhakungsprofil	
		Kunststoff Plastic	Hooking profile	
		schwarz black		
4930029	6,5 m 6,5 m	WICSLIDE 160	Wasserrinnenprofil	
		Kunststoff Plastic	Gutter profile	
		schwarz black	1040002,1041344,1940019,5010615	
4930033	6,5 m 6,5 m	WICSLIDE 160	HI Profil Entwässerungsöffnungen mit 5940042	
		Kunststoff Plastic	HI Profile Drainage openings with 5940042	
		schwarz black	5940042	
4930035	6,5 m 6,5 m	WICSLIDE 160	Führungsprofil	
		Kunststoff Plastic	Guide profile	
		schwarz black		
4930091	6,5 m 6,5 m	WICSLIDE 160	HI Profil Entwässerungsöffnungen mit 5940042	
		Kunststoff Plastic	HI Profile Drainage openings with 5940042	
		schwarz black	5940042	
4040610	100 St. 100 pcs	WICSLIDE 160	Entwässerungsabdeckung	
		PA	Weephole cover	
		grau grey weiß white schwarz black		

WICSLIDE 160

Kunststoffprofile, Formstücke
Plastic profiles, moulded pieces

Zubehör
Accessories

Artikel Article	VE PU	Anwendung Application	Bezeichnung / Hinweise Designation / Indications	Abbildung Figure
		Material / Material Farbe / Colour	Zuordnung Assignment	
4040086	100 St. 100 pcs	WICSLIDE 160	Abdeckkappe Bohrung Ø12 mm.	
		ABS	Cover cap Borehole Ø12 mm.	
		schwarz black		
4070030	100 St. 100 pcs	WICSLIDE 160	Leitteil für Injektion In Stoßverbinder stecken für Klebereinspritzung	
		PA	Injection guide part Insert in butt connector for glue injection	
4040456	10 Paar 10 pair	WICSLIDE 160	Endstück Fensterbank 140 - 160 mm	
			Plug for tubular sill insul. 140-160 mm	
		grau grey schwarz black	4000170	
4040678	10 St. 10 pcs	WICSLIDE 160	Abschlussstück Verbindungsstück: 1 x 4070025 (ST4.8 x 13)	
		PA	End piece Connecting device: 1 x 4070025 (ST4.8 x 13)	
		schwarz black	4020639,4030302	
4040700	20 St. 20 pcs	WICSLIDE 160	Kugelrückschlagventil Bohrdurchmesser Ø 10 mm Bohrschablone W5010622	
			Ball check valve Borehole Ø 10 mm drilling jig W5010622	
4940077	100 St. 100 pcs	WICSLIDE 160	Vorklotz Verwendung: Für alle Fensterrahmenprofile und Türflügelprofile! Gegen Abrutschen sichern!	
		PA	Glazing shim Application: For window frame profiles and door leaf profiles! Secure against slipping!	
		schwarz black	1916203	

WICSLIDE 160

Kunststoffprofile, Formstücke
Plastic profiles, moulded pieces



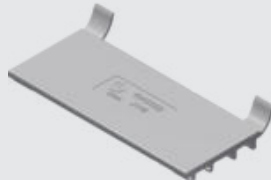
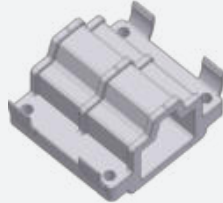
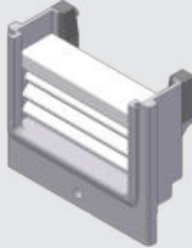
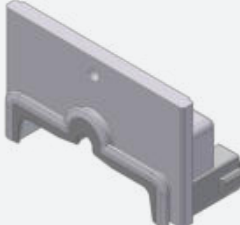
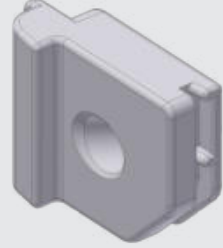

Zubehör
Accessories

Artikel Article	VE PU	Anwendung Application	Bezeichnung / Hinweise Designation / Indications	Abbildung Figure
		Material / Material Farbe / Colour	Zuordnung Assignment	
4940088	100 St. 100 pcs	WICSLIDE 160	Vorklotz Verwendung: Für alle Flügelprofile! Gegen Abrutschen sichern!	
		PA	Glazing shim Application: For all sash profiles! Secure against slipping!	
		schwarz black	1940037	
4940114	20 St. 20 pcs	WICSLIDE 160	Befestigungsteil Verbindungsmitel: 4 x 4970706 (ST4,2x19)	
		PA	Fixation part Connecting device: 4 x 4970706 (ST4,2x19)	
		schwarz black		
4940116	10 St. 10 pcs	WICSLIDE 160	Flügeldichtteil, oben	
			Sash sealing part, top	
		schwarz black		
4940117	10 St. 10 pcs	WICSLIDE 160	Flügeldichtteil, unten	
			Sash sealing part, bottom	
		schwarz black		
4940166	20 St. 20 pcs	WICSLIDE 160	Flügelleitteil	
		PA	Sash guidance part	
		schwarz black		

WICSLIDE 160

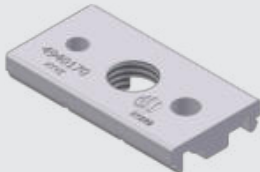
Kunststoffprofile, Formstücke
Plastic profiles, moulded pieces

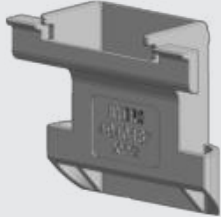
Zubehör
Accessories

Artikel Article	VE PU	Anwendung Application	Bezeichnung / Hinweise Designation / Indications	Abbildung Figure
		Material / Material Farbe / Colour	Zuordnung Assignment	
4940170	50 St. 50 pcs	WICSLIDE 160	Befestigungsteil Bauanschlussbefestigung: HUS-S 7.5, Dübel Ø8 mm, M16 für Adjufix-Befestigung	
		PA	Fastening part For fixation of junction to structure: HUS-S 7.5, Dowel Ø8 mm, M16 for Adjufix fixation	
		schwarz black		
8030015	6,5 m 6,5 m	WICSLIDE 160	Klipsprofil mit Hinterlegeband	
		PA	Clipping profile with back-filling strap	
		schwarz black		
4940187	20 St. 20 pcs	WICSLIDE 160	Entwässerungsteil, verdeckte Entwässerung, Falz 25 mm Einsetzbar für Blendrahmen- und Kämpferprofile bis Ansichtsbreite 140 mm! Nur mit 188413 einzusetzen!	
		PA	Drainage part for concealed drainage, rebate 25 mm Can be used for frame and transom profiles of up to 140 mm view width! Applicable only with 188413!	
		schwarz black	1916203	
4040085	10 St. 10 pcs	WICSLIDE 160	Kugelrückschlagventil Bohrung Ø12 mm.	
			Ball check valve Borehole Ø12 mm.	

WICSLIDE 160

Kunststoffprofile, Formstücke
Plastic profiles, moulded pieces



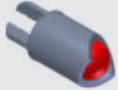

Zubehör
Accessories

Artikel <i>Article</i>	VE <i>PU</i>	Anwendung <i>Application</i>	Bezeichnung / Hinweise Designation / <i>Indications</i>	Abbildung <i>Figure</i>
		Material / <i>Material</i> Farbe / <i>Colour</i>	Zuordnung <i>Assignment</i>	
4940535	10 St. <i>10 pcs</i>	WICSLIDE 160	Kugelrückschlagventil Bohrdurchmesser Ø 8 mm	
		ABS	Ball check valve Borehole Ø 8 mm	
		schwarz <i>black</i>		

WICSLIDE 160

Eckwinkel, Blechteile
 Corner angles, Metal sheet parts

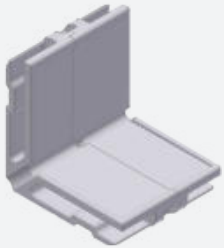
Zubehör
 Accessories

Artikel Article	VE PU	Anwendung Application	Bezeichnung / Hinweise Designation / Indications	Abbildung Figure
		Material / Material Farbe / Colour	Zuordnung Assignment	
4950008	20 St. 20 pcs	WICSLIDE 160	Al-Gusseckwinkel Verbindungselement: 2 x 4070000	
			Cast Al corner angle Connecting element: 2 x 4070000	
			1916203,1940019	
4050150	20 St. 20 pcs	WICSLIDE 160	Zentriereindrehteil Verwendung: Flügelüberschlag innen. Verkleben	
		Stahl, rostfrei Stainless steel	Centering turn-in part Application: Inner sash overlap. Glue	
4050153	20 St. 20 pcs	WICSLIDE 160	Zentriereindrehteil Verwendung: Flügelglasfalz außen. Verkleben	
		Stahl, rostfrei Stainless steel	Centering turn-in part Application: Sash outer glazing rebate. Glue	
4950092	20 St. 20 pcs	WICSLIDE 160	Al-Gusseckwinkel Verbindungselement: 2 x 4070000	
			Cast aluminium corner angle Connecting element: 2 x 4070000	
			1040001,1040002,1040004,1041344,1041345 1041346,1041347,1940006,1940019	
4950095	20 St. 20 pcs	WICSLIDE 160	Al-Gusseckwinkel Verbindungselement: 2 x 4070000	
		Al	Cast aluminium corner angle Connecting element: 2 x 4070000	
			1940037	
4950096	20 St. 20 pcs	WICSLIDE 160	Al-Gusseckwinkel Verbindungselement: 2 x 4070000	
			Cast aluminium corner angle Connecting element: 2 x 4070000	
			1040001,1040002,1040004	

WICSLIDE 160

Eckwinkel, Blechteile
 Corner angles, Metal sheet parts

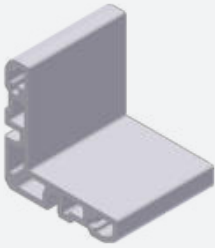
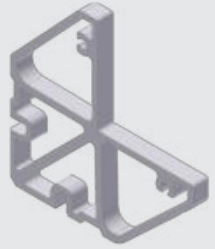
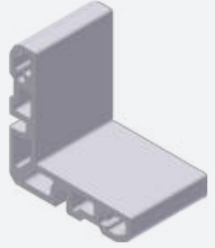

Zubehör
 Accessories

Artikel Article	VE PU	Anwendung Application	Bezeichnung / Hinweise Designation / Indications	Abbildung Figure
		Material / Material Farbe / Colour	Zuordnung Assignment	
4950099	20 St. 20 pcs	WICSLIDE 160	Al-Gusseckwinkel Verbindungselement: 2 x 4070000	
		Al	Cast aluminium corner angle Connecting element: 2 x 4070000	
			1940037	
4950239	20 St. 20 pcs	WICSLIDE 160	Al-Strangpresseckwinkel, Kammer 15 mm Verbindungselement: 2 x 4070000	
		Al	Extruded corner angle, chamber 15 mm Connecting element: 2 x 4070000	
			1040001,1040002,1040004,1041344,1041345 1041346,1041347,1940006,1940019	
4950264	20 St. 20 pcs	WICSLIDE 160	Al-Eckwinkel, Kammer 48 x 8.7 mm Verbindungselement: 2 x 4070000	
		Al	Corner angle, aluminium, chamber 48 x 8.7 mm Connecting element: 2 x 4070000	
			1940037	
4950266	20 St. 20 pcs	WICSLIDE 160	Al-Eckwinkel, Kammer 15 x 41.8 mm Verbindungselement: 2 x 4070000	
		Al	Corner angle, aluminium, chamber 15 x 41.8 mm Connecting element: 2 x 4070000	
			1040001,1040002,1040004	

WICSLIDE 160

Verbinder
Butt-joint connectors

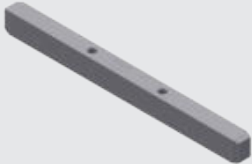
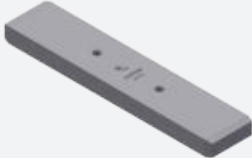
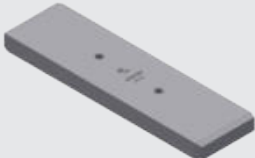

Zubehör
Accessories

Artikel Article	VE PU	Anwendung Application	Bezeichnung / Hinweise Designation / Indications	Abbildung Figure
		Material / Material Farbe / Colour	Zuordnung Assignment	
4060377	2 St. 2 pcs	WICSLIDE 160	Stoßverbinder Verlängerung Blendrahmenprofile horizontal mittig / außen Verbindungselement: 2 x 4070000	
		Al	Butt-joint connector Extension of frame profiles horizontal central / outside connecting element: 2 x 4070000	
			1040002,1940019	
4060386	2 St. 2 pcs	WICSLIDE 160	Stoßverbinder Verlängerung Blendrahmenprofile horizontal Mittenschale Verbindungselement: 2 x 4070000	
		Al	Butt-joint connector Extension of frame profiles horizontal middle profile shell Connecting element: 2 x 4070000	
			1040001,1040002,1040004	
4060388	2 St. 2 pcs	WICSLIDE 160	Stoßverbinder Verlängerung Blendrahmenprofile horizontal innen / außen Verbindungselement: 2 x 4070000	
		Al	Butt-joint connector Extension of frame profiles horizontal inside / outside connecting element: 2 x 4070000	
			1040001,1040002,1040004,1041344,1041345 1041346,1041347,1940006,1940019	
4960002	20 St. 20 pcs	WICSLIDE 160	Stoßverbinder Falz 25 mm, innen/außen Verbindungselement: 1 x 4070000	
			Butt-joint connector 25 mm rebate, inside/outside Connecting element: 1 x 4070000	
			1040010	

WICSLIDE 160

Zubehör
Accessories

Verbinder
Butt-joint connectors

Artikel Article	VE PU	Anwendung Application	Bezeichnung / Hinweise Designation / Indications	Abbildung Figure
		Material / Material Farbe / Colour	Zuordnung Assignment	
4960004	20 St. 20 pcs	WICSLIDE 160	Stoßverbinder Falz 25 mm, innen/außen Verbindungselement: 1 x 4070000 Injektionsleitteil: 1 x 4070030	
			Butt-joint connector 25 mm rebate, inside/outside Connecting element: 1 x 4070000 Injection guide part: 1 x 4070030	
			1916203	
4960009	10 St. 10 pcs	WICSLIDE 160	Stoßverbinder Falz 25 mm, innen/außen Verbindungselement: 2 x 4070000 Injektionsleitteil: 2 x 4070030	
			Butt-joint connector 25 mm rebate, inside/outside Connecting element: 2 x 4070000 Injection guide part: 2 x 4070030	
			1040010,1940041	
4960026	10 St. 10 pcs	WICSLIDE 160	Stoßverbinder Falz 22 mm, außen Verbindungselement: 1 x 4070000	
			Butt-joint connector 22 mm rebate, outside Connecting element: 1 x 4070000	
			1916203	

WICSLIDE 160

Verbindungselemente / Schrauben
Connecting components / Screws



Zubehör
Accessories

Artikel Article	VE PU	Anwendung Application	Bezeichnung / Hinweise Designation / Indications	Abbildung Figure
		Material / Material Farbe / Colour	Zuordnung Assignment	
198059	100 St. 100 pcs	WICSLIDE 160	Gewindestift M5 x 6.5 mm Vorwiegend in äußeren Verbindern.	
		Stahl Steel	Threaded pin M5 x 6.5 mm Mainly in outer connectors.	
4070000	100 St. 100 pcs	WICSLIDE 160	Hülse Ø6 x 10 mm Setzdorn 5060053 / 5060055	
		Stahl, rostfrei Stainless steel	Bush Ø6 x 10 mm Mandrel for drive bush 5060053 / 5060055	
4070002	100 St. 100 pcs	WICSLIDE 160	Kegelschraube Ø6.6 x 9.5 T25	
		Stahl rostfrei, A1 Stainless steel, A1	Screwed bush Ø6.6 x 9.5 T25	
4070008	100 St. 100 pcs	WICSLIDE 160	Hülse Ø6 x 10 mm Hülse ohne Bund.	
		Stahl, rostfrei Stainless steel	Bush Ø6 x 10 mm Bush without collar.	
4070010	100 St. 100 pcs	WICSLIDE 160	Zylinderkopfschraube M6 x 13.5 mm T25 Torx 25	
		Stahl rostfrei, A2 Stainless steel, A2	Socket-head cap screw M6 x 13.5 mm T25 Torx 25	
4070011	100 St. 100 pcs	WICSLIDE 160	Gewindestift M5 x 12 mm T8 Torx 8	
		Stahl Steel	Threaded pin M5 x 12 mm T8 Torx 8	

WICSLIDE 160

Zubehör
Accessories





Verbindungselemente / Schrauben
Connecting components / Screws

Artikel Article	VE PU	Anwendung Application	Bezeichnung / Hinweise Designation / Indications	Abbildung Figure
		Material / Material Farbe / Colour	Zuordnung Assignment	
4070012	100 St. 100 pcs	WICSLIDE 160	Zylinderkopfschraube M5 x 9 mm T10 Torx 10	
		Stahl rostfrei, A2 Stainless steel, A2	Socket-head cap screw M5 x 9 mm T10 Torx 10	
4970722	10 St. 10 pcs	WICSLIDE 160	Gewindestift ISO 4026 M6 x 30 Innensechskant 3 mm	
		Stahl Steel	Grub screw ISO 4026 M6 x 30 Hexagon socket 3 mm	

WICSLIDE 160

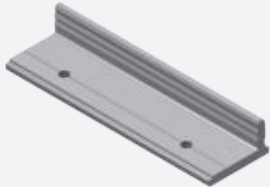
Verschiedenes
Miscellaneous



Zubehör
Accessories

Artikel Article	VE PU	Anwendung Application	Bezeichnung / Hinweise Designation / Indications	Abbildung Figure
		Material / Material Farbe / Colour	Zuordnung Assignment	
4080452	10 St. 10 pcs	WICSLIDE 160	Halter für Abdeckprofil 3041321	
		Al	Bracket for cover profile 3041321	
4080454	10 St. 10 pcs	WICSLIDE 160	Befestigungsteil für Kunststoff-Dämmauflage	
		Al	Fixation part for thermal break profile	
4000207	10 St. 10 pcs	WICSLIDE 160	Kennzeichnungsschild, Einbruchhemmung Im Flügel falz unterhalb des Griffes einkleben	
		Al	Identification marking plate, burglar resistance Glue in sash rebate, below handle.	
			1940037	
4080318	100 St. 100 pcs	WICSLIDE 160	Befestigungsteil	
			Fixing lug support	
		kadmiert cadmium coated		
4080350	50 St. 50 pcs	WICSLIDE 160	Befestigungswinkel, fluchtend 160 mm Isolierung Unterer Befestigungswinkel, für verstärkte Fensterbank 160 mm	
		Stahl Steel	Fixing bracket, aligned 160 mm insulation Bottom fixing bracket, aligned reinforced sill 160 mm	
		kadmiert cadmium coated		
4080367	10 St. 10 pcs	WICSLIDE 160	Befestigungsteil für barrierefreie Schwelle Verwendung mit Profil 3090163, 3 St./m	
			Fixing part for barrier-free threshold Used with profile 3090163. 3 pieces/ml	

WICSLIDE 160

Verschiedenes
Miscellaneous

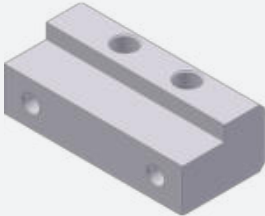
Zubehör
Accessories

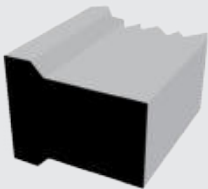
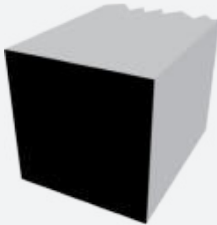
Artikel Article	VE PU	Anwendung Application	Bezeichnung / Hinweise Designation / Indications	Abbildung Figure
		Material / Material Farbe / Colour	Zuordnung Assignment	
4900073	6,5 m 6,5 m	WICSLIDE 160	Laufschiene	
		Stahl, rostfrei Stainless steel	Slide rail	
4980064	10 St. 10 pcs	WICSLIDE 160	Flügelbefestigungsteil Verbindungselement: 2 x 4970706	
		Al	Sash fixation part Connecting element: 2 x 4970706	
4980065	10 St. 10 pcs	WICSLIDE 160	Flügelbefestigungsteil Verbindungselement: 2 x 4970056	
		Al	Sash fixation part Connecting element: 2 x 4970056	
4990005	5 St. 5 pcs	WICSLIDE 160	Einschub Länge: 1m	
		PE	Insertion length: 1m	
			1940037	
4990012	5 St. 5 pcs	WICSLIDE 160	Einschub Länge: 1m	
		PE	Insertion length: 1m	
			1940037	
4990013	5 St. 5 pcs	WICSLIDE 160	Einschub Länge: 1m	
		PE	Insertion length: 1m	
			1940037	

WICSLIDE 160

Zubehör
Accessories

Verschiedenes
Miscellaneous

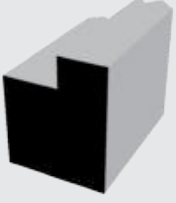
Artikel Article	VE PU	Anwendung Application	Bezeichnung / Hinweise Designation / Indications	Abbildung Figure
		Material / Material Farbe / Colour	Zuordnung Assignment	
4990018	5 St. 5 pcs	WICSLIDE 160	Einschub Länge: 1m	
		PE	Insertion length: 1m	
			1940037	

WICSLIDE 160

Verbindungselemente
Connecting components

Zubehör
Accessories

Artikel <i>Article</i>			VE <i>PU</i>	Bezeichnung <i>Designation</i>	Abbildung <i>Figure</i>
4070056	T20	ST4.2 x 16	100 St.	Senkblechschraube	
4070115	T25	ST4.8 x 25	100 St.	ähnlich DIN 7982	
4070163	T25	ST4.8 x 32	100 St.	Stahl rostfrei, A2	
4070164	T25	ST4.8 x 100	100 St.	<i>Self-tapping countersunk screw similar DIN 7982 Stainless steel, A2</i>	

WICSLIDE 160

Verbindungselemente
Connecting components

Zubehör
Accessories

Artikel <i>Article</i>			VE <i>PU</i>	Bezeichnung <i>Designation</i>	Abbildung <i>Figure</i>
4070046	T20	ST4.2 x 13	100 St.	Linsenblechschraube	
4970706	T20	ST4.2 x 19	100 St.	ähnlich DIN ISO 7049	
4070047	T20	ST4.2 x 25	100 St.		
4070025	T25	ST4.8 x 13	100 St.		
4070026	T25	ST4.8 x 16	100 St.	<i>Self-tapping pan head screw</i>	
4070525	T25	ST4.8 x 75	100 St.	<i>similar DIN ISO 7049</i>	

WICSLIDE 160

Verbindungselemente
Connecting components

Zubehör
Accessories



Artikel <i>Article</i>			VE <i>PU</i>	Bezeichnung <i>Designation</i>	Abbildung <i>Figure</i>
198133	SR2	ST4.2 x 11	100 St.	Selbstbohrschraube mit Linsenkopf Gewinde ähnlich DIN ISO 7049, Kopf ähnlich DIN 7984 Stahl rostfrei, A2 <i>Self drilling screw 4,2 x 11mm Thread similar DIN ISO 7049, head similar DIN 7984 Stainless steel, A2</i>	

	Seite Page
Hebe-Schiebetüren <i>Lifting sliding doors</i>	5/3
Hebe-Schiebetüren, Zubehör <i>Lifting sliding doors, accessories</i>	5/10
Hebe-Schiebetüren, RC <i>Lifting sliding doors, RC</i>	5/15

WICSLIDE 160

Hebe-Schiebetüren
Lifting sliding doors



Beschläge
Hardware

Artikel Article	VE PU	Farbe Colour	DIN DIN	Attribut Attribute	Bezeichnung / Hinweise Designation / Indications	Abbildung Figure
6950012	1 1	roh <i>untreated</i>	R+L	Schema A Schema D Schema A Schema D	Hebe-Schiebe Grundbeschlag HS 300 Lifting sliding basis fitting HS 300	
6950061	1 1	roh <i>untreated</i>	R+L		Ergänzungssatz HS 400 für Tandemlaufwerk Extension Set HS 400 for Tandem roller	
6950013	1 1	roh <i>untreated</i>	R+L	GR 180 Flügelhöhe 1200 - 1913 mm PZ GR 180 Sash height 1200 - 1913 mm PZ	Hebe-Schiebe Getriebe mit Riegelbolzen Lifting sliding gear with catch bolt	
6950014	1 1	roh <i>untreated</i>	R+L	GR 210 Flügelhöhe 1914 - 2213 mm PZ GR 210 Sash height 1914 - 2213 mm PZ		

WICSLIDE 160

Hebe-Schiebetüren
Lifting sliding doors



Beschläge
Hardware

Artikel Article	VE PU	Farbe Colour	DIN DIN	Attribut Attribute	Bezeichnung / Hinweise Designation / Indications	Abbildung Figure
6950015	1 1	roh <i>untreated</i>	R+L	GR 240 Flügelhöhe 2214 - 2513 mm PZ GR 240 Sash height 2214 - 2513 mm PZ	Hebe-Schiebe Getriebe mit Riegelbolzen Lifting sliding gear with catch bolt.	
6950016	1 1	roh <i>untreated</i>	R+L	GR 270 Flügelhöhe 2514 - 2813 mm PZ GR 270 Sash height 2514 - 2813 mm PZ		
6950017	1 1	roh <i>untreated</i>	R+L	GR 180 Flügelhöhe 1200 - 1913 mm RZ GR 180 Sash height 1200 - 1913 mm RZ	Hebe-Schiebe Getriebe mit Riegelbolzen Lifting sliding gear with catch bolt	
6950018	1 1	roh <i>untreated</i>	R+L	GR 210 Flügelhöhe 1914 - 2213 mm RZ GR 210 Sash height 1914 - 2213 mm RZ		

WICSLIDE 160

Hebe-Schiebetüren
Lifting sliding doors



Beschläge
Hardware

Artikel Article	VE PU	Farbe Colour	DIN DIN	Attribut Attribute	Bezeichnung / Hinweise Designation / Indications	Abbildung Figure
6950019	1 1	roh <i>untreated</i>	R+L	GR 240 Flügelhöhe 2214 - 2513 mm RZ GR 240 Sash height 2214 - 2513 mm RZ	Hebe-Schiebe Getriebe mit Riegelbolzen Lifting sliding gear with catch bolt.	
6950020	1 1	roh <i>untreated</i>	R+L	GR 270 Flügelhöhe 2514 - 2813 mm RZ GR 270 Sash height 2514 - 2813 mm RZ		
6950169	1 1	roh <i>untreated</i>	R+L		Getriebeverlängerung mit Riegelbolzen Gear extension with catch bolt	

WICSLIDE 160

Hebe-Schiebetüren
Lifting sliding doors



Beschläge
Hardware

Artikel Article	VE PU	Farbe Colour	DIN DIN	Attribut Attribute	Bezeichnung / Hinweise Designation / Indications	Abbildung Figure
6950021	1 1	roh <i>untreated</i>	R+L	GR 180 Flügelhöhe 1200 - 1913 mm PZ GR 180 Sash height 1200 - 1913 mm PZ	Hebe-Schiebe Getriebe ohne Riegelbolzen Lifting sliding gear without catch bolt	
6950022	1 1	roh <i>untreated</i>	R+L	GR 210 Flügelhöhe 1914 - 2213 mm PZ GR 210 Sash height 1914 - 2213 mm PZ		
6950023	1 1	roh <i>untreated</i>	R+L	GR 240 Flügelhöhe 2214 - 2513 mm PZ GR 240 Sash height 2214 - 2513 mm PZ	Hebe-Schiebe Getriebe ohne Riegelbolzen Lifting sliding gear without catch bolt.	
6950024	1 1	roh <i>untreated</i>	R+L	GR 270 Flügelhöhe 2514 - 2813 mm PZ GR 270 Sash height 2514 - 2813 mm PZ		

WICSLIDE 160

Hebe-Schiebetüren
Lifting sliding doors



Beschläge
Hardware

Artikel Article	VE PU	Farbe Colour	DIN DIN	Attribut Attribute	Bezeichnung / Hinweise Designation / Indications	Abbildung Figure
6950025	1 1	roh <i>untreated</i>	R+L	GR 180 Flügelhöhe 1200 - 1913 mm RZ GR 180 Sash height 1200 - 1913 mm RZ	Hebe-Schiebe Getriebe ohne Riegelbolzen Lifting sliding gear without catch bolt	
6950026	1 1	roh <i>untreated</i>	R+L	GR 210 Flügelhöhe 1914 - 2213 mm RZ GR 210 Sash height 1914 - 2213 mm RZ		
6950027	1 1	roh <i>untreated</i>	R+L	GR 240 Flügelhöhe 2214 - 2513 mm RZ GR 240 Sash height 2214 - 2513 mm RZ	Hebe-Schiebe Getriebe ohne Riegelbolzen Lifting sliding gear without catch bolt.	
6950028	1 1	roh <i>untreated</i>	R+L	GR 270 Flügelhöhe 2514 - 2813 mm RZ GR 270 Sash height 2514 - 2813 mm RZ	Hebe-Schiebe Getrieb ohne Riegelbolzen Lifting sliding gear without catch bolt.	

WICSLIDE 160

Hebe-Schiebetüren
Lifting sliding doors



Beschläge
Hardware

Artikel Article	VE PU	Farbe Colour	DIN DIN	Attribut Attribute	Bezeichnung / Hinweise Designation / Indications	Abbildung Figure
6050326	1 1	roh <i>untreated</i>			Getriebeverlängerung ohne Riegelbolzen Gear extension <i>without catch bolt</i>	
6950029	1 1	roh <i>untreated</i>	R+L	GR 180 Flügelhöhe 1200-1913 Griffhöhe 409 mm PZ <i>GR 180 Sash height 1200-1913 Handle height 409 mm PZ</i>	Hebe-Schiebe Getriebe mit Verriegelung nach oben Lifting sliding gear <i>with locking towards the top</i>	
6950030	1 1	roh <i>untreated</i>	R+L	GR 210 Flügelhöhe 1914-2213 PZ <i>GR 210 Sash height 1914-2213 PZ</i>		
6950031	1 1	roh <i>untreated</i>	R+L	GR 240 Flügelhöhe 2214-2513 PZ <i>GR 240 Sash height 2214-2513 PZ</i>	Hebe-Schiebe Getriebe mit Verriegelung nach oben Lifting sliding gear <i>with locking towards the top.</i>	
6950032	1 1	roh <i>untreated</i>	R+L	GR 270 Flügelhöhe 2514-2813 PZ <i>GR 270 Sash height 2514-2813 PZ</i>		

WICSLIDE 160

Hebe-Schiebetüren
Lifting sliding doors

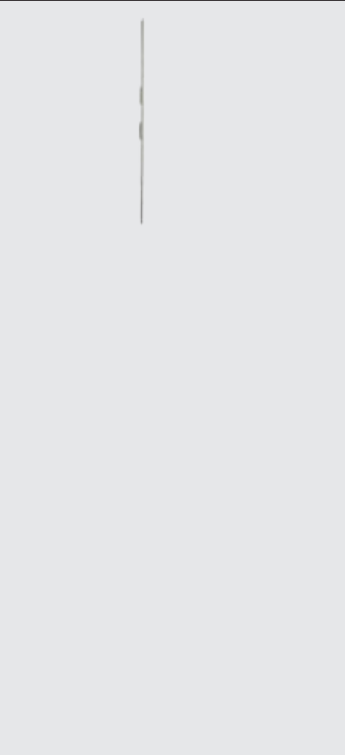

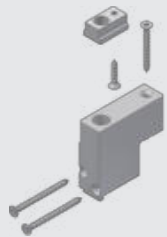
Beschläge
Hardware

Artikel Article	VE PU	Farbe Colour	DIN DIN	Attribut Attribute	Bezeichnung / Hinweise Designation / Indications	Abbildung Figure
6950033	1 1	roh <i>untreated</i>	R+L	GR 180 Flügelhöhe 1200-1913 Griffhöhe 409 mm RZ GR 180 Sash height 1200-1913 Handle height 409 mm RZ	Hebe-Schiebe Getriebe mit Verriegelung nach oben Lifting sliding gear with locking towards the top	
6950034	1 1	roh <i>untreated</i>	R+L	GR 210 Flügelhöhe 1914-2213 RZ GR 210 Sash height 1914-2213 RZ		
6950035	1 1	roh <i>untreated</i>	R+L	GR 240 Flügelhöhe 2214-2513 RZ GR 240 Sash height 2214-2513 RZ	Hebe-Schiebe Getriebe mit Verriegelung nach oben Lifting sliding gear with locking towards the top.	
6950036	1 1	roh <i>untreated</i>	R+L	GR 270 Flügelhöhe 2514-2813 RZ GR 270 Sash height 2514-2813 RZ		
6000005	2 2	roh <i>untreated</i>	R+L		Befestigungsgarnitur für Hebe-Schiebe Getriebe mit Verriegelung nach oben Fixing set for lifting sliding gears with locking towards the top	

WICSLIDE 160

Hebe-Schiebetüren Zubehör
Lifting sliding doors accessory



Beschläge
Hardware

Artikel Article	VE PU	Farbe Colour	DIN DIN	Attribut Attribute	Bezeichnung / Hinweise Designation / Indications	Abbildung Figure
6950038	1 1 1 1 1 1	E6/C0 Sonderfarbe RAL9016 <i>anodized</i> <i>Special colour</i> <i>RAL9016</i>	R+L		Griff-Garnitur einseitig innen Handle set <i>one-sided inside</i>	
6950039	1 1 1 1 1 1	E6/C0 Sonderfarbe RAL9016 <i>anodized</i> <i>Special colour</i> <i>RAL9016</i>	R+L		Griff-Garnitur einseitig innen, mit Griffmuschel außen Handle set <i>one-sided inside, with external</i> <i>finger grip</i>	
6950040	1 1 1 1 1 1	E6/C0 Sonderfarbe RAL9016 <i>anodized</i> <i>Special colour</i> <i>RAL9016</i>	R+L	PZ	Griff-Garnitur einseitig innen Handle set <i>one-sided inside</i>	
6950042	1 1 1 1 1 1	E6/C0 Sonderfarbe RAL9016 <i>anodized</i> <i>Special colour</i> <i>RAL9016</i>	R+L	RZ		

WICSLIDE 160

Hebe-Schiebetüren Zubehör
Lifting sliding doors accessory





Beschläge
Hardware

Artikel Article	VE PU	Farbe Colour	DIN DIN	Attribut Attribute	Bezeichnung / Hinweise Designation / Indications	Abbildung Figure
6950041	1	E6/C0	R+L	PZ	Griff-Garnitur einseitig innen, mit Griffmuschel außen Handle set one-sided, inside with external finger grip	
	1	Sonderfarbe RAL9016				
	1	anodized Special colour RAL9016				
6950043	1	E6/C0	R+L	RZ		
	1	Sonderfarbe RAL9016				
	1	anodized Special colour RAL9016				
6950044	1	E6/C0	R+L	PZ	Griff-Garnitur beidseitig Handle set on both sides	
	1	Sonderfarbe RAL9016				
	1	anodized Special colour RAL9016				
6950045	1	E6/C0	R+L	RZ		
	1	Sonderfarbe RAL9016				
	1	anodized Special colour RAL9016				
6950051	1	silber	R+L		Griff für Putzflügel Handle for cleaning sash	
	1	silver				

WICSLIDE 160

Hebe-Schiebetüren Zubehör
Lifting sliding doors accessory





Beschläge
Hardware

Artikel Article	VE PU	Farbe Colour	DIN DIN	Attribut Attribute	Bezeichnung / Hinweise Designation / Indications	Abbildung Figure
6920071	1 1	roh <i>untreated</i>	R+L	Maß a/i 45/45 mm Überst. a/i 7,5/7,5 mm WS 75 <i>Dim. o/i</i> 45/45 mm <i>Protr. o/i</i> 7,5/7,5 mm WS 75	Profilzylinder nach EN 1303 verschiedenschließend mit 3 Schlüsseln Profile cylinder acc. to EN 1303 individually keyed with 3 keys	
6920241	1 1	roh <i>untreated</i>	R+L	Maß a/i 45/9,5 mm Überst. a/i 7,5/0 mm WS 75 <i>Dim. o/i</i> 45/9,5 mm <i>Protr. o/i</i> 7,5/0 mm WS 75	Profil- Halbzylinder nach EN 1303 verschiedenschließend mit 3 Schlüsseln Profile semi-cylinder acc. to EN 1303 individually keyed with 3 keys	
6950047	1 1	roh <i>untreated</i>	R+L	L = 68 mm	Befestigungsgarnitur Griff einseitig innen, mit Griffmuschel außen Fixing set one-sided handle inside, with external finger grip	
6950049	1 1	roh <i>untreated</i>	R+L	L = 108 mm	Befestigungsgarnitur Griff beidseitig Fixing set Handle on both sides	
6950170	1 1	roh <i>untreated</i>	R+L	L = 88 mm	Befestigungsgarnitur Griff einseitig innen Fixing set one-sided handle inside	

WICSLIDE 160

Hebe-Schiebetüren Zubehör
Lifting sliding doors accessory



Beschläge
Hardware

Artikel Article	VE PU	Farbe Colour	DIN DIN	Attribut Attribute	Bezeichnung / Hinweise Designation / Indications	Abbildung Figure
6950054	1 1	roh <i>untreated</i>	R+L		Verbindungsstange GR 150 L = 858 mm HS 300: FAB 770-1568 HS 400: FAB 1380-2158 Connecting rod GR 150 L = 858 mm HS 300: FAB 770-1568 HS 400: FAB 1380-2158	
6950055	1 1	roh <i>untreated</i>	R+L		Verbindungsstange GR 200 L = 1358 mm HS 300: FAB 1569-2068 HS 400: FAB 2159-2658 Connecting rod GR 200 L = 1358 mm HS 300: FAB 1569-2068 HS 400: FAB 2159-2658	
6950056	1 1	roh <i>untreated</i>	R+L		Verbindungsstange GR 250 L = 1858 mm HS 300: FAB 2069-2568 HS 400: FAB 2659-3158 Connecting rod GR 250 L = 1858 mm HS 300: FAB 2069-2568 HS 400: FAB 2659-3158	
6950057	1 1	roh <i>untreated</i>	R+L		Verbindungsstange GR 323 L = 2598 mm HS 300: FAB 2569-3235 HS 400: FAB 3159-3235 Connecting rod GR 323 L = 2598 mm HS 300: FAB 2569-3235 HS 400: FAB 3159-3235	
6950060	1 1	roh <i>untreated</i>	R+L		Zusatzverriegelung Additional locking point	

WICSLIDE 160

Hebe-Schiebetüren Zubehör
Lifting sliding doors accessory





Beschläge
Hardware

Artikel Article	VE PU	Farbe Colour	DIN DIN	Attribut Attribute	Bezeichnung / Hinweise Designation / Indications	Abbildung Figure
6950058	1 1 1 1	weiß schwarz white black	R+L		Flügelanschlag Sash stop	
6000006	2 2 2 2	E6/C0 E6/C35 anodized anodized black	R+L		Unterlegplatte Flügelanschlagbefestigung auf Laufschiene Support plate Sash stop fixation on slide rail	
6081398	1 1	roh untreated	R+L		Verschlusskontrolle Komplett mit Sensor und Magneteinheit Kontaktart: A/Schließer max. Schaltspannung: U _{max} = 100 V DC max. Schaltstrom: I _{max} = 0,5 A max. Kontaktbelastung: P _{max} = 10 W Schutzart: IP 68 nach DIN 40050 Kabel: 6 m, LIYY 4 x 0.14 mm ² , weiss Locking Control Complete with sensor and magnet unit Contact type: A/closer max. switching voltage: U _{max} = 100 V DC max. switching DC: I _{max} = 0,5 A max. contact load: P _{max} = 10 W Protection class: IP 68 acc. DIN 40050 Cable: 6 m, LIYY 4 x 0.14 mm ² , white	

WICSLIDE 160

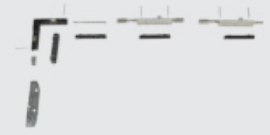
Hebe-Schiebetüren, RC
Lifting sliding doors, RC



Beschläge
Hardware

Artikel Article	VE PU	Farbe Colour	DIN DIN	Attribut Attribute	Bezeichnung / Hinweise Designation / Indications	Abbildung Figure
6950300	1 1	roh <i>untreated</i>	R+L		EH Ergänzungssatz Extension set burglary resistance	
6051032	1 1	roh <i>untreated</i>	R+L		OL Zugstange zum Einhängen Ø 8 mm Länge = 2000 mm Fanlight operation rod to hook in Ø 8 mm length = 2000 mm	
6051033	1 1	roh <i>untreated</i>	R+L		OL Zugstange zum Einhängen Ø 8 mm Länge = 2500 mm Fanlight operating rod to hook in Ø 8 mm length = 2500 mm	
6950059	10 10	roh <i>untreated</i>	R+L		Riegelbock Verriegelung unten Bottom locking Locking at bottom	

WICSLIDE 160

Hebe-Schiebetüren, RC
Lifting sliding doors, RC

Beschläge
Hardware

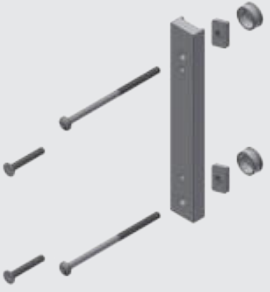
Artikel Article	VE PU	Farbe Colour	DIN DIN	Attribut Attribute	Bezeichnung / Hinweise Designation / Indications	Abbildung Figure
6000010	1 1	roh <i>untreated</i>			Zusatzverriegelung RC2/RC2N Additional locking point RC2/RC2N	
6000011	1 1	roh <i>untreated</i>			Befestigungsgarnitur für Flügel RC2/RC2N Fixing set for sashes RC2/RC2N	
6000012	1 1	roh <i>untreated</i>			Befestigungsgarnitur für Flügelstoß RC2/RC2N Fixing set for meeting stile RC2/RC2N	

	Seite Page
Sägebeilagen <i>Sawing shims</i>	6/3
Schablonen <i>Templates</i>	6/4
Stanzwerkzeuge <i>Punching tools</i>	6/6
Presstawerkzeuge <i>Crimping tools</i>	6/10
Verschiedenes <i>Miscellaneous</i>	6/12
Hilfsstoffe <i>Auxilliary means</i>	6/21

WICSLIDE 160

Werkzeuge
Tools

Sägebeilagen
Sawing shims

Artikel Article	VE PU	Anwendung Application	Bezeichnung / Hinweise Designation / Indications	Abbildung Figure
		Material / Material Farbe / Colour	Zuordnung Assignment	
5950023	1 Garn. 1 set	WICSLIDE 160	Sägebeilage 1 Garnitur = 2 Paar	
			Sawing shim 1 set = 2 pair	
			1940037	

WICSLIDE 160

Werkzeuge
Tools





Schablonen
Templates

Artikel Article	VE PU	Anwendung Application	Bezeichnung / Hinweise Designation / Indications	Abbildung Figure
		Material / Material Farbe / Colour	Zuordnung Assignment	
5010641	1 St. 1 pcs	WICSLIDE 160	Bohrschablone für Zusatzverriegelung 6000010	
			Drill template for additional locking point 6000010	
5010598	1 St. 1 pcs	WICSLIDE 160	Bohrschablone für Entwässerung	
			Drill template for drainage	
			1040002,1041344,1940019	
5010615	1 St. 1 pcs	WICSLIDE 160	Bohrschablone für Entwässerung Verwendung mit Tiefenanschlag 5060402	
			Drill template for drainage Use with bit stop 5060402	
			1040002,1041344,1940019,4930029	
5010622	1 St. 1 pcs	WICSLIDE 160	Bohrschablone für Entwässerung Verwendung mit Tiefenanschlag 5060402	
			Drill template for drainage Use with bit stop 5060402	
			1040001,1040002,1040004,1041345,1041346 1041347,1940006	
5010625	1 St. 1 pcs	WICSLIDE 160	Adapter für Bohrschablone 5910062 Entwässerung Blendrahmen	
			Adapter for drill template 5910062 Drainage of frame	
			1041344,1041345,1041346	
5910041	1 St. 1 pcs	WICSLIDE 160	Bohrschablone Eckverbindung Flügel	
			Drill template Corner connection of sash	
			1940037	

WICSLIDE 160

Werkzeuge
Tools



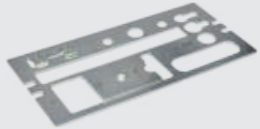

Schablonen
Templates

Artikel Article	VE PU	Anwendung Application	Bezeichnung / Hinweise Designation / Indications	Abbildung Figure
		Material / Material Farbe / Colour	Zuordnung Assignment	
5910051	1 St. 1 pcs	WICSLIDE 160	Bohrschablone Eckverbindung Blendrahmen	
			Drill template Corner connection of frame	
			1040001,1040002,1040004,1041344,1041345 1041346,1041347,1940006,1940019	
5910057	1 St. 1 pcs	WICSLIDE 160	Bohrschablone Eckverbindung Blendrahmen 3-bahnig, Mittenschale	
			Drill template Corner connection frame 3 track, middle profile shell	
			1040001,1040002,1040004	
5910062	1 St. 1 pcs	WICSLIDE 160	Bohrschablone Entwässerung Blendrahmen	
			Drill template Drainage of frame	
			1040001,1040002,1040004,1041345,1041346 1041347,1940006	
5910073	1 St. 1 pcs	WICSLIDE 160	Bohrschablone Eckverbindung Blendrahmen 1-bahnig und Stoßverbindung Pfostenprofil	
			Drill template Corner connection of frame 1 track and butt-joint connection of mullion profile	
			1040002,1040010,1916203,1940019,1940041	
5010630	1 St. 1 pcs	WICSLIDE 160	Frässchablone	
			Milling template	

WICSLIDE 160

Stanzwerkzeuge
Punching tools



Werkzeuge
Tools

Artikel Article	VE PU	Anwendung Application	Bezeichnung / Hinweise Designation / Indications	Abbildung Figure
		Material / Material Farbe / Colour	Zuordnung Assignment	
5040000	1 St. 1 pcs	WICSLIDE 160	Multifunktionsstanzwerkzeug bestehend aus Pneumatikpresse und Werkzeugaufnahme	
			Multi-functional punching tool consisting of pneumatic press and tool carrier	
5040003	1 St. 1 pcs	WICSLIDE 160	Arbeitsstisch für Multifunktionsstanzwerkzeug	
			Work bench for multi-functional punching tool	
5040004	1 St. 1 pcs	WICSLIDE 160	Längenanschlag zum Anbau an das Multifunktionsstanzwerkzeug	
			Length limiter for fitting on multi-functional punching tool	
5040005	1 St. 1 pcs	WICSLIDE 160	Wartungseinheit für Multifunktionsstanze	
			Maintenance unit for multi-functional punching tool	
5040421	1 St. 1 pcs	WICSLIDE 160	Wechselwerkzeug für 5040000 Stanzung für Flügeldichtteil 4940116 (oben) und 4940117 (unten)	
			Interchangeable tool for 5040000 Punching for sash sealing part 4940116 (top) and 4940117 (bottom)	
			3041309	

WICSLIDE 160

Stanzwerkzeuge
Punching tools





Werkzeuge
Tools

Artikel Article	VE PU	Anwendung Application	Bezeichnung / Hinweise Designation / Indications	Abbildung Figure
		Material / Material Farbe / Colour	Zuordnung Assignment	
5940001	1 St. 1 pcs	WICSLIDE 160	Wechselwerkzeug für 5040000 Eck- und Stoßverbindung Blendrahmen	
			Interchangeable tool for 5040000 Corner and butt-joint connection of frame profile	
			1040010,1916203,1940019,1940041	
5940014	1 St. 1 pcs	WICSLIDE 160	Wechselwerkzeug für 5040000 Eckverbindung Flügel	
			Interchangeable tool for 5040000 Corner connection of sash profiles	
			1940037	
5940015	1 St. 1 pcs	WICSLIDE 160	Wechselwerkzeug für 5040000 Eckverbindung Blendrahmen	
			Interchangeable tool for 5040000 Corner connection of frame	
			1041344,1041345,1041346,1041347,1940006	
5940028	1 St. 1 pcs	WICSLIDE 160	Wechselwerkzeug für 5040000 Entwässerung Flügel	
			Interchangeable tool for 5040000 Drainage of sash profiles	
			1940037	
5940030	1 St. 1 pcs	WICSLIDE 160	Wechselwerkzeug für 5040000 Stanzung für Flügeldichtteil 4940116 (oben) und 4940117 (unten)	
			Interchangeable tool for 5040000 Punching for sash sealing part 4940116 (top) and 4940117 (bottom)	
			3940009,3940010	
5940031	1 St. 1 pcs	WICSLIDE 160	Wechselwerkzeug für 5040000 Stegausklinkung für Flügelaufsatzprofil	
			Interchangeable tool for 5040000 Web notching for sash supplementary profile	
			3940009,3940010	

WICSLIDE 160

Werkzeuge
Tools

Stanzwerkzeuge
Punching tools

Artikel Article	VE PU	Anwendung Application	Bezeichnung / Hinweise Designation / Indications	Abbildung Figure
		Material / Material Farbe / Colour	Zuordnung Assignment	
5940042	1 St. 1 pcs	WICSLIDE 160	Wechselwerkzeug für 5040000 Entwässerungsstanzungen an HI-Kunststoffprofil	
			Interchangeable tool for 5040000 Drainage punch in hi-plastic profile	
			4930033,4930091	
5040101	1 St. 1 pcs	WICSLIDE 160	Handstanzengrundkörper zur Bestückung mit Wechselwerkzeugen Pneumatische Handstanze für Wechselwerkzeuge	
			Hand punching tool For interchangeable tools	
5940101	1 St. 1 pcs	WICSLIDE 160	Wechselwerkzeug für 5040101 Eck- und Stoßverbindung Blendrahmen	
			Interchangeable tool for 5040101 Frame and transom connection	
			1040010,1916203,1940019,1940041	
5940113	1 St. 1 pcs	WICSLIDE 160	Wechselwerkzeug für 5040101 Eckverbindung Flügel	
			Interchangeable tool for 5040101 Corner connection of sash profile	
			1940037	
5940115	1 St. 1 pcs	WICSLIDE 160	Wechselwerkzeug für 5040101 inkl. 2x Adapter Eckverbindung Blendrahmen	
			Interchangeable tool for 5040101 incl. 2x adapter Corner connection of frame	
			1040001,1040002,1040004,1041344,1041345 1041346,1041347,1940006,1940019	

WICSLIDE 160

Werkzeuge
Tools

Stanzwerkzeuge
Punching tools

Artikel Article	VE PU	Anwendung Application	Bezeichnung / Hinweise Designation / Indications	Abbildung Figure
		Material / Material Farbe / Colour	Zuordnung Assignment	
5040150	1 St. 1 pcs	WICSLIDE 160	Dichtungsstanze pneumatisch zum Ablängen von Dichtungsprofilen	
			Pneumatic gasket punch for cutting gasket profiles to length	
5040151	1 St. 1 pcs	WICSLIDE 160	Arbeitstisch für Dichtungsstanze 5040150	
			Work bench for gasket punch 5040150	
5040152	1 St. 1 pcs	WICSLIDE 160	Längenanschlag für Dichtungsstanze 5040150	
			Length limiter for gasket punch 5040150	
5040166	1 St. 1 pcs	WICSLIDE 160	Ersatz-Schneidplatte für 90°-Schnitt für Dichtungsstanze 5040150	
			Replacement cutting plate for 90° cut for gasket punch 5040150	

WICSLIDE 160

Werkzeuge
Tools

Presstawerkzeuge
Crimping tools

Artikel Article	VE PU	Anwendung Application	Bezeichnung / Hinweise Designation / Indications	Abbildung Figure
		Material / Material Farbe / Colour	Zuordnung Assignment	
5030075	1 Paar 1 pair	WICSLIDE 160	Presstawerkzeug-Satz	
		Stahl Steel	Crimping tool set	
			1040004,1041344,1041345,1041346	
5930001	1 Paar 1 pair	WICSLIDE 160	Presstawerkzeug-Satz	
		Stahl Steel	Crimping tool set	
			1916203,1940019	
5930013	1 Paar 1 pair	WICSLIDE 160	Presstawerkzeug-Satz	
			Crimping tool set	
			1940037	
5930014	1 Paar 1 pair	WICSLIDE 160	Presstawerkzeug-Satz	
			Crimping tool set	
			1040001,1040002,1041347,1940006,1940019	
5030100	1 Paar 1 pair	WICSLIDE 160	Messeradapter für Pressta Eisele PV10	
		Stahl Steel	Knife adaptor for Eisele PV10 crimping tool	
5030101	1 Paar 1 pair	WICSLIDE 160	Messeradapter für Elumatec EP124	
		Stahl Steel	Knife adaptor for Elumatec EP124	

WICSLIDE 160

Werkzeuge
Tools



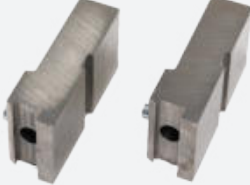



Presstawerkzeuge
Crimping tools

Artikel Article	VE PU	Anwendung Application	Bezeichnung / Hinweise Designation / Indications	Abbildung Figure
		Material / Material Farbe / Colour	Zuordnung Assignment	
5030102	1 Paar 1 pair	WICSLIDE 160	Messeradapter für Loth Uniprä 250	
		Stahl Steel	Knife adaptor for Loth Uniprä 250	
5030103	1 Paar 1 pair	WICSLIDE 160	Messeradapter für Rapid HP205 / HP208	
		Stahl Steel	Knife adaptor for Rapid HP 205 / HP 208	

WICSLIDE 160

Werkzeuge
Tools

Verschiedenes
Miscellaneous

Artikel Article	VE PU	Anwendung Application	Bezeichnung / Hinweise Designation / Indications	Abbildung Figure
		Material / Material Farbe / Colour	Zuordnung Assignment	
5060001	1 St. 1 pcs	WICSLIDE 160	Tiefenanschlag für Bohrer Ø8 mm	
			Bit stop for Ø8 mm drill	
5060002	1 St. 1 pcs	WICSLIDE 160	Kegelsenker 80° Ø8 mm	
			Countersink 80°, Ø8 mm	
5060003	1 St. 1 pcs	WICSLIDE 160	Kegelsenker 80° Ø10 mm	
			Countersink 80°, Ø10 mm	
5060004	1 St. 1 pcs	WICSLIDE 160	Kegelsenker 80° Ø13.4 mm	
			Countersink 80°, Ø13.4 mm	
5060012	1 St. 1 pcs	WICSLIDE 160	Bithalter Längsgriff mit Bitverriegelung	
			Bit holder with longitudinal handle with bit lock	
5060013	5 St. 5 pcs	WICSLIDE 160	Schraubenbit T8 Länge 70 mm	
			Screwdriver bit T8 Length 70 mm	

WICSLIDE 160

Werkzeuge
Tools





Verschiedenes
Miscellaneous

Artikel Article	VE PU	Anwendung Application	Bezeichnung / Hinweise Designation / Indications	Abbildung Figure
		Material / Material Farbe / Colour	Zuordnung Assignment	
5060014	5 St. 5 pcs	WICSLIDE 160	Schraubenbit T10 Länge 70 mm	
			Screwdriver bit T10 Length 70 mm	
5060015	5 St. 5 pcs	WICSLIDE 160	Schraubenbit T15 Länge 70 mm	
			Screwdriver bit T15 Length 70 mm	
5960012	5 St. 5 pcs	WICSLIDE 160	Schraubenbit T15 Länge 50 mm, mit Haltefunktion	
			Screwdriver bit T15 Length 50 mm, with retaining function	
5060016	5 St. 5 pcs	WICSLIDE 160	Schraubenbit T20 Länge 70 mm	
			Screwdriver bit T20 Length 70 mm	
5960013	5 St. 5 pcs	WICSLIDE 160	Schraubenbit T20 Länge 50 mm, mit Haltefunktion	
			Screwdriver bit T20 Length 50 mm, with retaining function	
5060017	5 St. 5 pcs	WICSLIDE 160	Schraubenbit T25 Länge 70 mm	
			Screwdriver bit T25 Length 70 mm	

WICSLIDE 160

Werkzeuge
Tools





Verschiedenes
Miscellaneous

Artikel Article	VE PU	Anwendung Application	Bezeichnung / Hinweise Designation / Indications	Abbildung Figure
		Material / Material Farbe / Colour	Zuordnung Assignment	
5060024	1 St. 1 pcs	WICSLIDE 160	Diamant-Sägeblatt zur Verarbeitung unserer Systemprofile aus Aluminium, hohe Standzeit	
			Diamond saw blade for processing our system profiles made of aluminium, high operating life.	
5060025	1 St. 1 pcs	WICSLIDE 160	Diamant-Fräser Ø 10 mm x 100 mm, nutzbare Schneide 20 mm, zur Verarbeitung unserer Systemprofile aus Aluminium, hohe Standzeit	
			Diamond milling cutter Ø10 mm x 100 mm, usable cutting edge 20 mm, for processing our system profiles made of aluminium, high operating life	
5960007	1 St. 1 pcs	WICSLIDE 160	Torx Schraubendreher T10 auf Längsgriff	
			Torx screw driver T10 with longitudinal handle	
5060031	1 St. 1 pcs	WICSLIDE 160	Torx Schraubendreher T25 auf Längsgriff	
			Torx screwdriver T25 with longitudinal handle	
5060032	1 St. 1 pcs	WICSLIDE 160	Torx Schraubendreher T25 auf Quergriff	
			Torx screwdriver T25 with cross handle	

WICSLIDE 160

Werkzeuge
Tools



Verschiedenes
Miscellaneous

Artikel Article	VE PU	Anwendung Application	Bezeichnung / Hinweise Designation / Indications	Abbildung Figure
		Material / Material Farbe / Colour	Zuordnung Assignment	
5060051	1 St. 1 pcs	WICSLIDE 160	Profi-Drucklufthammer inkl. Setzdorn Eck- und Stoßverbindung	
			Professional pneumatic hammer including set mandrel for corner and butt-joint connections	
5060053	1 St. 1 pcs	WICSLIDE 160	Setzdorn für Hülse Ø6 mm auf Profi Drucklufthammer 5060051 Eck- und Stoßverbindung	
			Set mandrel mounted on professional pneumatic hammer 5060051 for Ø6 mm drive bush for corner and butt-joint connection	
5060055	1 St. 1 pcs	WICSLIDE 160	Setzdorn für Hülse Ø6 mm manuell Eck- und Stoßverbindung	
			Set mandrel for Ø6 mm drive bush, manual for corner and butt-joint connection	
5060060	1 St. 1 pcs	WICSLIDE 160	Roller mit Kunststoffwanne für Kleberauftrag auf Schnittfläche Eck- und Stoßverbindung	
			Roller with plastic tray for application of adhesive on cut surfaces of profiles for corner and butt-joint connections	
5060061	1 St. 1 pcs	WICSLIDE 160	Ersatzrolle für Roller 5060060	
			Replacement roller for roller 5060060	

WICSLIDE 160

Werkzeuge
Tools

Verschiedenes
Miscellaneous

Artikel Article	VE PU	Anwendung Application	Bezeichnung / Hinweise Designation / Indications	Abbildung Figure
		Material / Material Farbe / Colour	Zuordnung Assignment	
5060422	1 St. 1 pcs	WICSLIDE 160	Schnittkanten-Abdichtungsmaschine zur Anwendung von WICPRO-Tector zum Abdichten von Profil-Schnittflächen. Ersatzfolie 5070229.	
			Cut surfaces sealing machine for application of WICPRO-Tector for sealing profile cut surfaces. Replacement foil 5070229.	
5060424	1 Garn. 1 set	WICSLIDE 160	Kartuschenpresse, akkubetrieben 10,8 V / 1,5 Ah für 2K Klebstoff 2 x 310 ml, Eck- und Stoßverbindung	
			Cartridges press, rech. battery-powered 10,8 V / 1,5 Ah for 2C adhesive 2 x 310 ml, angle and butt joints	
5060425	1 St. 1 pcs	WICSLIDE 160	Ersatzakku 10,8 V / 1,5 Ah Li-Ion für Injektionspistole akkubetrieben	
			Replacement accu 10,8 V / 1,5 Ah Li-Ion for injection gun battery powered	
5060426	1 St. 1 pcs	WICSLIDE 160	Kartuschenpresse, manuell für 2K Klebstoff 2 x 310 ml, Eck- und Stoßverbindung	
			Cartridges press, manual for 2C adhesive 2 x 310 ml, angle and butt joints	

WICSLIDE 160

Werkzeuge
Tools







Verschiedenes
Miscellaneous

Artikel Article	VE PU	Anwendung Application	Bezeichnung / Hinweise Designation / Indications	Abbildung Figure
		Material / Material Farbe / Colour	Zuordnung Assignment	
5060070	1 St. 1 pcs	WICSLIDE 160	Injektionspistole manuell Eck- und Stoßverbindung	
			Injection pistol, manual Corner and butt-joint connections	
5060071	1 St. 1 pcs	WICSLIDE 160	Injektionspistole pneumatisch Eck- und Stoßverbindung	
			Injection pistol, pneumatic Corner and butt-joint connections	
5060073	1 St. 1 pcs	WICSLIDE 160	Klebstoffportioniergerät	
			Adhesive portioning apparatus	
5060075	1 St. 1 pcs	WICSLIDE 160	Reinigungsmittelpender als Sparanfeuchter	
			Cleaner-dispenser as economy dampener	
5060076	1 St. 1 pcs	WICSLIDE 160	Sprühdose pneumatisch	
			Spray can, pneumatic	
5060077	1 St. 1 pcs	WICSLIDE 160	Druckluft-Tankstelle für Sprühdose	
			Compressed air filling station for spray can	

WICSLIDE 160

Werkzeuge
Tools





Verschiedenes
Miscellaneous

Artikel Article	VE PU	Anwendung Application	Bezeichnung / Hinweise Designation / Indications	Abbildung Figure
		Material / Material Farbe / Colour	Zuordnung Assignment	
5060080	1 St. 1 pcs	WICSLIDE 160	Dichtungsschere	
			Gasket shear	
5060089	1 St. 1 pcs	WICSLIDE 160	Ersatzklingen für Dichtungsschere 5060080	
			Replacement blades for gasket shear 5060080	
5060101	1 St. 1 pcs	WICSLIDE 160	Abspulbock für Dichtungsprofile auf Mehrwegspule	
			Gasket reel support rack for gasket profiles on reusable reels	
5060102	1 St. 1 pcs	WICSLIDE 160	Abroller für Dichtungsprofile auf Mehrwegspule	
			Portable reel holder for gasket profiles on reusable reels,	
5060103	1 St. 1 pcs	WICSLIDE 160	Beschlagsmontagewagen klein	
			Trolley for installation of fittings, small	
5060104	1 St. 1 pcs	WICSLIDE 160	Beschlagsmontagewagen groß	
			Trolley for installation of fittings, large	

WICSLIDE 160

Werkzeuge
Tools

Verschiedenes
Miscellaneous

Artikel Article	VE PU	Anwendung Application	Bezeichnung / Hinweise Designation / Indications	Abbildung Figure
		Material / Material Farbe / Colour	Zuordnung Assignment	
5060105	1 St. 1 pcs	WICSLIDE 160	Arbeitstisch	
			Work-bench	
5060107	1 St. 1 pcs	WICSLIDE 160	Folienabroller für Folienarbeiten bis 150 mm Selbstzuschnitt aus Rolle 5070043	
			Foil dispenser for foil works up to 150 mm width, cut to size from the roll 5070043	
5060400	1 Garn. 1 set	WICSLIDE 160	Montagehilfe für Laufwagen	
		Al	Assembling aid for runner 160	
5060401	1 St. 1 pcs	WICSLIDE 160	Stufenbohrer Ø 5.3 mm / Ø 3.5 mm für 6950012 (HS 300), 6950061 (HS 400)	
		Stahl Steel	Step drill Ø 5.3 mm / Ø 3.5 mm for 6950012 (HS 300), 6950061 (HS 400)	
5060402	1 St. 1 pcs	WICSLIDE 160	Tiefenanschlag für Bohrer Ø 10.2 mm für Bohrschablone 5010595, 5010615, 5010616, 5010622	
			Bit stop for Ø 10.2 mm drill for drill template 5010595, 5010615, 5010616, 5010622	

WICSLIDE 160

Werkzeuge
Tools





Verschiedenes
Miscellaneous

Artikel Article	VE PU	Anwendung Application	Bezeichnung / Hinweise Designation / Indications	Abbildung Figure
		Material / Material Farbe / Colour	Zuordnung Assignment	
5060419	1 St. 1 pcs	WICSLIDE 160	Schlitzfräser 38.5 x 7 mm für Entwässerung Blendrahmen	
		Stahl Steel	Keyway cutter 38.5 x 7 mm for drainage of frame profiles	
			1040001,1040002,1040004,1041345,1041346 1041347,1940006	

WICSLIDE 160

Werkzeuge
Tools

Hilfsstoffe
Auxiliary means

Artikel Article	VE PU	Anwendung Application	Bezeichnung / Hinweise Designation / Indications	Abbildung Figure
		Material / Material Farbe / Colour	Zuordnung Assignment	
5070000	1 Set 1 set	WICSLIDE 160	2-Komponenten Polyurethan-Klebstoff in Tandemkartusche 1 Set = 6 Stück inkl. 8 Statikmischer zum Verkleben von Al-Profilen	
			2-component Polyurethane adhesive in tandem cartridge 1 set = 6 pieces including 8 mixing nozzle to glue aluminium profiles	
5970002	1 Set 1 set	WICSLIDE 160	2-Komponenten Polyurethan-Klebstoff, schwarz in Tandemkartusche 1 Set = 6 Stück inkl. 8 Statikmischer zum Verkleben von Al-Profilen	
			2-component Polyurethane adhesive, black in tandem cartridge 1 set = 6 pieces including 8 mixing nozzle to glue aluminium profiles	
5070001	20 St. 20 pcs	WICSLIDE 160	Statikmischer für Tandemkartusche	
			Mixing nozzle for tandem cartridge	
5070002	1 Set 1 set	WICSLIDE 160	2-Komponenten Epoxid-Klebstoff in Dosengebinde für Portioniergerät Komponenten A+B zum Verkleben von Al- Profilen	
			2-component epoxy adhesive in tins for portioning apparatus, component A+B, to glue aluminium profiles	
5070224	1 St. 1 pcs	WICSLIDE 160	WICPRO-Tector zum Abdichten von Schnittkanten, weiß	
			WICPRO-Tector for sealing mitre cut surfaces, white	

WICSLIDE 160

Werkzeuge
Tools





Hilfsstoffe
Auxiliary means

Artikel Article	VE PU	Anwendung Application	Bezeichnung / Hinweise Designation / Indications	Abbildung Figure
		Material / Material Farbe / Colour	Zuordnung Assignment	
5070225	1 St. 1 pcs	WICSLIDE 160	WICPRO-Tector zum Abdichten von Schnittkanten, grau	
			WICPRO-Tector for sealing mitre cut surfaces, grey	
5070226	1 St. 1 pcs	WICSLIDE 160	WICPRO-Tector zum Abdichten von Schnittkanten, schwarz	
			WICPRO-Tector for sealing mitre cut surfaces, black	
5070227	10 St. 10 pcs	WICSLIDE 160	2-Komponenten Polyurethan-Klebstoff in Tandemkartusche 2 x 310 ml 1 Set = 10 Stück inkl. 10 Statikmischer zum Verkleben von Al- Profilen	
			2 components polyurethane adhesive in tandem cartridge 2 x 310ml 1 set = 10 pieces including 10 mixing nozzles to glue aluminium profiles	
5070003	1 St. 1 pcs	WICSLIDE 160	Farbpaste weiß zum Einfärben von Klebstoff	
			Colour paste, white for colouration of adhesive	
5070004	1 Set 1 set	WICSLIDE 160	Farbpalette mit 5 Grundfarben, zum Einfärben von Klebstoff	
			Colour palette with 5 basic colours, for colouration of adhesive	

WICSLIDE 160

Werkzeuge
Tools





Hilfsstoffe
Auxiliary means

Artikel Article	VE PU	Anwendung Application	Bezeichnung / Hinweise Designation / Indications	Abbildung Figure
		Material / Material Farbe / Colour	Zuordnung Assignment	
5070012	1 St. 1 pcs	WICSLIDE 160	Dichtungskleber, schwarz	
			Gasket glue, black	
5070015	1 St. 1 pcs	WICSLIDE 160	Reinigungsmittel 1 l für pulverbeschichtete und eloxierte Profile	
			Cleaning agent, 1 litre for powder coated and anodized profiles	
5070016	1 St. 1 pcs	WICSLIDE 160	Reinigungsmittel 10 l für pulverbeschichtete und eloxierte Profile	
			Cleaning agent, 10 litre for powder coated and anodized profiles	
5070024	1 St. 1 pcs	WICSLIDE 160	Gleitfett säure- und harzfrei zum Fetten der Beschlüge beim Einbau	
			Grease free from acid and resin to lubricate fittings while assembling	
5070025	1 St. 1 pcs	WICSLIDE 160	Pflegespray für Stanzen und Beschlüge säure- und harzfrei zum nachträglichen Pflegen und Fetten der Beschlagsteile und Stanzwerkzeuge	
			Maintenance spray for punching and fittings free from acid and resin for subsequent maintenance and greasing of fitting parts and punching tools	

WICSLIDE 160

Werkzeuge
Tools



Hilfsstoffe
Auxiliary means

Artikel Article	VE PU	Anwendung Application	Bezeichnung / Hinweise Designation / Indications	Abbildung Figure
		Material / Material Farbe / Colour	Zuordnung Assignment	
5070229	12 St. 12 pcs	WICSLIDE 160	Ersatzfolie für Schnittkanten-Abdichtungsmaschine 5060422.	
			Replacement foil for cut surfaces sealing machine 5060422.	
5070043	100 m 100 m	WICSLIDE 160	Schutzfolie 1250 mm für Selbstzuschnitt, selbsthaftend, Transportschutz für behandelte Profile	
			Protective foil 1250 mm for cut to size, self-adhesive, as transport protection for surface treated profiles	
5070044	20 St. 20 pcs	WICSLIDE 160	Dichtmasse, silikonfrei 310 ml zum Abdichten in Fällen, wo silikonhaltige Stoffe nicht zulässig sind. Farbe: schwarz	
			Sealing compound, without silicone, 310 ml to seal in cases where materials containing silicone are not permissible. Colour: black	
5370004	5 St. 5 pcs	WICSLIDE 160	Reinigungsmittel 1 l Sonderreiniger für die Schweiz	
			Cleaning agent, 1 litre Special cleaner for Switzerland	
5370005	1 St. 1 pcs	WICSLIDE 160	Reinigungsmittel 10 l Sonderreiniger für die Schweiz	
			Cleaning agent 10 litre Special cleaner for Switzerland	

WICSLIDE 160

Werkzeuge
Tools

Hilfsstoffe
Auxiliary means

Artikel Article	VE PU	Anwendung Application	Bezeichnung / Hinweise Designation / Indications	Abbildung Figure
		Material / Material Farbe / Colour	Zuordnung Assignment	
5970003	20 St. 20 pcs	WICSLIDE 160	SILCOSEAL Silikon-Dichtmasse 310 ml, schwarz zum Abdichten von Baufugen, für Abdichtungsarbeiten bei Riegelstößen oder zur Hinterlegung auf Gehrung geschnittener Glasdichtungen.	
			SILCOSEAL Silicone sealant, 310 ml, black <i>for sealing construction joints, transom joints or backlining mitre cut glazing gaskets.</i>	
5970004	20 St. 20 pcs	WICSLIDE 160	SILCOSEAL Silikon-Dichtmasse 310 ml, grau zum Abdichten von Baufugen, für Abdichtungsarbeiten bei Riegelstößen oder zur Hinterlegung auf Gehrung geschnittener Glasdichtungen.	
			SILCOSEAL Silicone sealant, 310 ml, grey <i>for sealing construction joints, transom joints or backlining mitre cut glazing gaskets.</i>	
5970006	1 Flasche 1 bottle	WICSLIDE 160	Primer / Reiniger 1,0 l in Kombination mit SILCOSEAL Silikon-Dichtmasse zur Vorbehandlung und Haftverbesserung auf beschichteten und unbeschichteten metallischen Werkstoffen. Beschichtung vor Anwendung prüfen, Datenblatt beachten.	
			Primer / Cleaner, 1.0 litre <i>in combination with SILCOSEAL silicone sealant for pre-treatment and adhesion improvements on coated and uncoated metals. Test coating prior to application, pay attention to data specification.</i>	

	Seite <i>Page</i>
Statik - Richtlinien <i>Static guidelines</i>	7/3
Statikdiagramm <i>Static diagram</i>	7/5
Statikdiagramm Windlast <i>Static diagram wind load</i>	7/6
Statikdiagramm Glaslast <i>Static diagram glass load</i>	7/18
Statische Werte <i>Statical values</i>	7/21
Eckwinkelzuschnitt / Auswahltabellen <i>Cutting corner angle / Selection tables</i>	7/27
Zertifikate <i>Certificates</i>	7/28

EN 14024

Anforderungen und mechanisches Leistungsverhalten von Metallprofilen mit thermischer Trennung (Verbundprofile)

Requirements and mechanical performance of metal profiles with thermal break (Composite profiles)

Vorbemerkung

Die statischen Erfordernisse von tragenden Gliedern sind entsprechend den jeweiligen Anforderungen zu dimensionieren. In vielen Anwendungsfällen ist ein statischer Nachweis erforderlich.

Definition: Metallprofil mit thermischer Trennung

Verbundprofil, zusammengesetzt aus zwei oder mehr Metallprofilen, die miteinander durch mindestens einen wärmedämmenden Bestandteil (nichtmetallisch) verbunden sind.

Die statischen Eigenschaften von Verbundprofilen und deren Nachweis unterscheiden sich wesentlich von Traggliedern aus nur einem Grundwerkstoff.

Inhalt der Norm (Deutsche Fassung)

In dieser Norm sind die Anforderungen an die Beurteilung der mechanischen Festigkeit von Verbundprofilen festgelegt. Es legt auch die Prüfungen zur Bestimmung der charakteristischen Werte von mechanischen Eigenschaften des Verbundprofils und die Beurteilung der Eignung der als thermische Trennung verwendeten Werkstoffe fest. Dieses Dokument gilt für Verbundprofile, die hauptsächlich für Fenster, Türen, Fensterwände und Vorhangfassaden vorgesehen sind.

Kategorien für den Gebrauch

Kategorie W

Metallprofile mit thermischer Trennung hauptsächlich für Fenster, Türen und Sekundärbauteile von Vorhangfassaden.

Anmerkung

Verbundprofile für Fenster und Türen erfordern gewöhnlich keinen Nachweis für die Berechnung der mechanischen Festigkeit.

Kategorie CW

Metallprofile mit thermischer Trennung hauptsächlich für die Bauteile von Vorhangfassaden mit Spannweiten größer als 2,25 m.

Der Nachweis beinhaltet neben den üblichen Lasten (Eigengewicht, Wind, weitere Verkehrslasten) im besonderen Temperaturbelastungen (Sommer, Winter) und deren Auswirkungen auf die Biegespannungen und Schubspannungen, speziell auf die nachgewiesenen Eigenschaften des „Elastischen Verbundes“ dieser Profile.

Verformungsbemessung – Ermittlung der Trägheitsmomente

Die zul. Verformung der Profile wird im Regelfall durch die Füllung definiert.

Bsp.: Glasfüllung $f_{zul.} = L/200$, max. 15 mm.

Die Ermittlung des Trägheitsmomentes erfolgt abhängig von dieser Verformung (dem stat. System), der Stützweite und der Belastung. Bedingt durch die Theorie des elastischen Verbundes ergeben sich bei Metall-Kunststoff-Verbundprofilen stützweitenabhängig unterschiedliche Trägheitsmomente. Die Ermittlung der Trägheitsmomente erfolgt mit den bekannten Methoden und Tabellen.



Wichtiger Hinweis:

Die ausreichende statische Bemessung und sichere Tragfähigkeit der verwendeten Profile obliegt der Verantwortung des Anwenders.



Important hints:

Adequate static dimensioning and secured load bearing capacity of the used profiles lies in the responsibility of user.

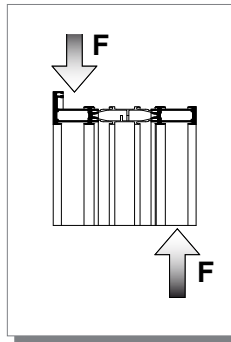

Schubfestigkeit
Shear strength

Preliminary remarks

The static requirements of supporting elements should be dimensioned according to the respective requirements. A statical evidence is necessary in many cases of application.

Definition: Metal profile with thermal break

Composite profile of two or more metal profiles connected with each other through minimum one insulating component (non-metallic).

The statical characteristics of composite profiles and their evidence differ substantially from supporting elements of only one base material.

Contents of Standard

Requirements on the evaluation of mechanical strength of composite profiles are specified in this standard. It also prescribes the tests for determining the characteristic value of mechanical properties of composite profiles and the evaluation of applicability of used material as thermal insulation. This document applies for composite profiles which are provided mainly for windows, doors, window walls and curtain walls.

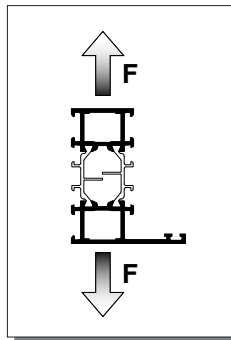

Querzugfestigkeit
Transverse tensile strength

Categories for use

Category W

Metal profiles with thermal break mainly for windows, doors and secondary structural components of curtain walls.

Annotation

Usually, composite profiles for windows and doors do not require evidence for the calculation of mechanical strength.

Category CW

Metal profiles with thermal break mainly for structural components of curtain walls with span widths larger than 2.25 m.

Next to the usual loads (own weight, wind, further live loads), the evidence includes particularly thermal loads (summer, winter) and their influence on bending stresses and shearing stresses, especially on the proven properties of "composite elasticity" of these profiles.

Dimensioning deformation - Determination of moment of inertia

As a rule, the admissible deformation of profiles is defined through the infill.

Example: Glass infill $f_{adm.} = L/200$, max. 15 mm.

The determination of moment of inertia follows depending on this deformation (static system) of bearing span and load.

Induced by the theory of composite elasticity, the different moments of inertia of metal-plastic composite profiles result from the bearing span dependent width. The determination of moment of inertia follows with the known methods and tables.

Die benötigten Lasten wie Windlast, Eigenlast und Verkehrslast für die nachfolgenden Diagramme sind den jeweils gültigen nationalen Normen und Vorschriften zu entnehmen.

The required loads for the following diagrams, such as wind load, dead load and live load are to be determined according to the respective valid national standards and instructions.

Anwendung der verschiedenen Diagramme

Rechtecklast Diagramme 1 – 3 und Dreieck- und Trapezlast Diagramme 4 – 6

Die Diagramme für Dreieck- und Trapezlast sind für eine annähernde Bestimmung des erforderlichen Trägheitsmomentes in x-Richtung anwendbar, d. h. Belastung senkrecht zur Verglasung. Bei Dreieck- und Trapezbelastung wird die Lastaufteilung nach DIN 1045 angenommen. Die Aufteilung erfolgt durch die Halbierung der Winkel. (Nach DIN 1045 für allseitig frei gelagerte Platte).

Application of the different diagrams

Rectangular load diagrams 1 – 3 and Triangular and trapezoidal load diagrams 4 – 6

The diagrams for triangular and trapezoidal load are applicable for a approx. determination of the required moment of inertia in x-direction, i.e. load perpendicular to glazing. For triangular and trapezoidal load the load distribution is assumed according to DIN 1045. The distribution is carried out by means of dividing the angles in two (plate with no bearings all over according to DIN 1045).

Glaslast Diagramm 7

Das Diagramm für Glaslast ist für eine annähernde Bestimmung des erforderlichen Trägheitsmomentes bei Riegeln und Kämpfern in y-Richtung anwendbar, d. h. in Belastungsrichtung der Verglasung. Als zulässige Durchbiegung werden $f_{zul} = 3 \text{ mm}$ angenommen.

Glass load diagram 7

The diagram for glass load is applicable for an approx. determination of the required moment of inertia for transom in y-direction, i.e. in the load direction of the glazing. The admissible deflection is assumed $f_{adm} = 3 \text{ mm}$.

Lastaufteilung bei Rechtecklast
*Load distribution rectangular load
(curtain wall)*

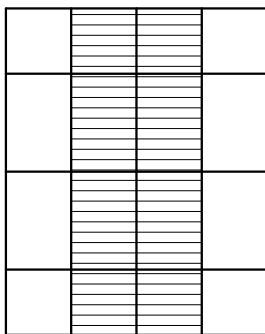

tatsächliche Aufteilung
auf die Stütze
*actual distribution on the
mullion*

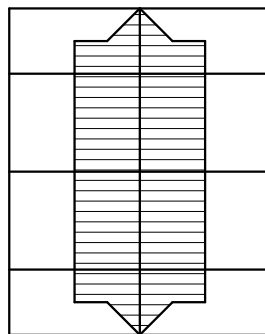

Lastaufteilung nach
DIN 1045
*Load distribution according
to DIN 1045*

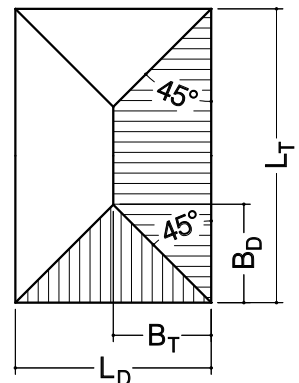

Die nachfolgenden Diagramme dienen zur überschlägigen Ermittlung der erforderlichen Trägheitsmomente. Die Diagramme sind nach bestem Wissen gefertigt. Eine Gewähr für Fehlerfreiheit kann jedoch nicht übernommen werden. Für verbindliche Festlegungen ist eine statische Berechnung erforderlich.



The diagrams are applicable for a rough determination of the required moment of inertia. The diagrams have been made to the best of our knowledge. However, no responsibility is taken for its correctness. In order to obtain binding results a statical check is necessary.

$$f_{zul. / adm.} = L / 200$$

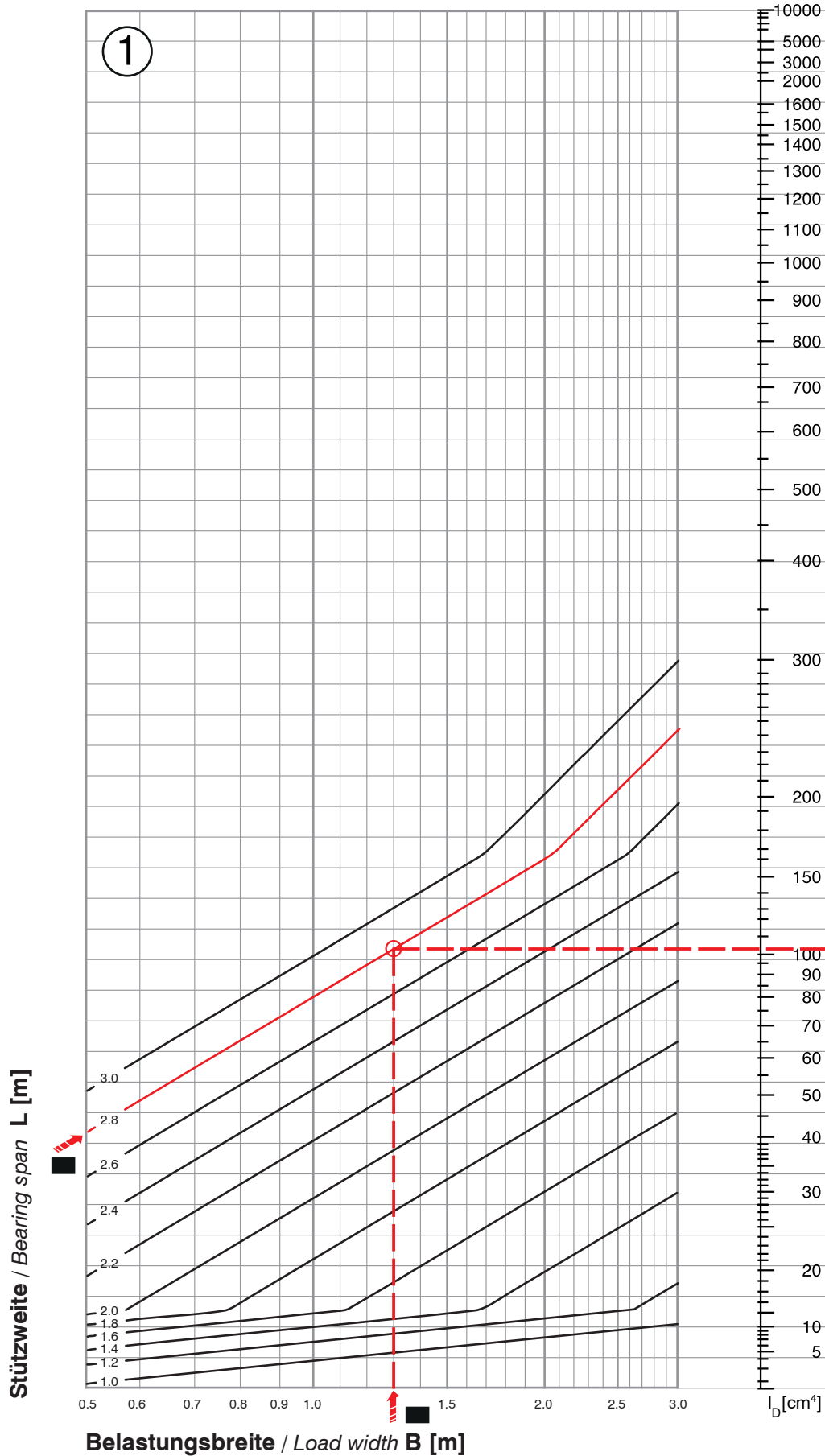

Rechtecklast (Einheitslast 1.0 kN/m²)
Rectangular load (Unit load 1.0 kN/m²)

$$f_{\text{zul. / adm.}} = L / 200$$

System / System

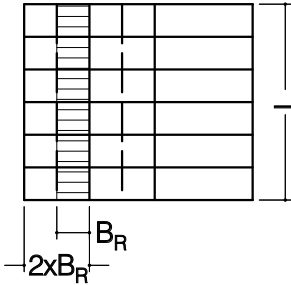

Anwendungsbeispiel Rechtecklast Example of application rectangular load

Stützweite / Bearing span:

$$L = 2.80 \text{ m}$$

Belastungsbreite / Load width:

$$B = 1.30 \text{ m}$$

Rechtecklast / Rectangular load:

$$I_D = 106 \text{ cm}^4 \text{ (ⓐ abgelesen / is read)}$$

Ermittlung: erf. I_x / Determination: requ. I_x

Beispiel / Example:

Winddruck angenommen* / Wind pressure assumed*

$$= 0.64 \text{ kN/m}^2$$

$$\text{erf. / requ. } I_x = w_e \cdot I_D = 0.64 \cdot 106 \text{ cm}^4$$

$$= 67.8 \text{ cm}^4$$

Windsog angenommen* / Wind suction assumed*

$$= -1.12 \text{ kN/m}^2$$

$$\text{erf. / requ. } I_x = w_e \cdot I_D = (-1.12) \cdot 106 \text{ cm}^4$$

$$= 118.7 \text{ cm}^4$$

*die Windlast muß nach den gültigen Normen und nach Standort und Form des Gebäudes ermittelt werden.

*the wind suction must be determined according to the valid standards and to the position and shape of the building.

Statisches System Rechtecklast

Statical system rectangular load

Träger auf 2 Stützen / Beam on 2 supports

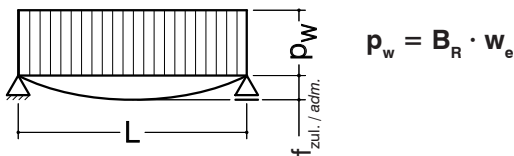

Berechnungsformel Rechtecklast

Calculation formula rectangular load

$$I_x = \frac{5 \cdot p_w \cdot L^4}{384 \cdot E \cdot f_{\text{zul. / adm.}}}$$

I_x	(cm ⁴) =	Trägheitsmoment / Moment of inertia
I_D	(cm ⁴) =	Trägheitsmoment, Rechtecklast / Moment of inertia, rectangular load
L	(cm) =	Stützweite / Bearing span
B	(cm) =	Belastungsbreite / Load width
w_e	(kN/cm ²) =	Winddruck/Windsog / Wind pressure/-depression
p_w	(kN/cm) =	Linienlast / Line load
E	(kN/cm ²) =	Elastizitätsmodul / Modulus of elasticity $7 \cdot 10^3$
$f_{\text{zul. / adm.}}$	(cm) =	zul. Durchbiegung / adm. deflection

$$f_{zul. / adm.} = L / 300$$

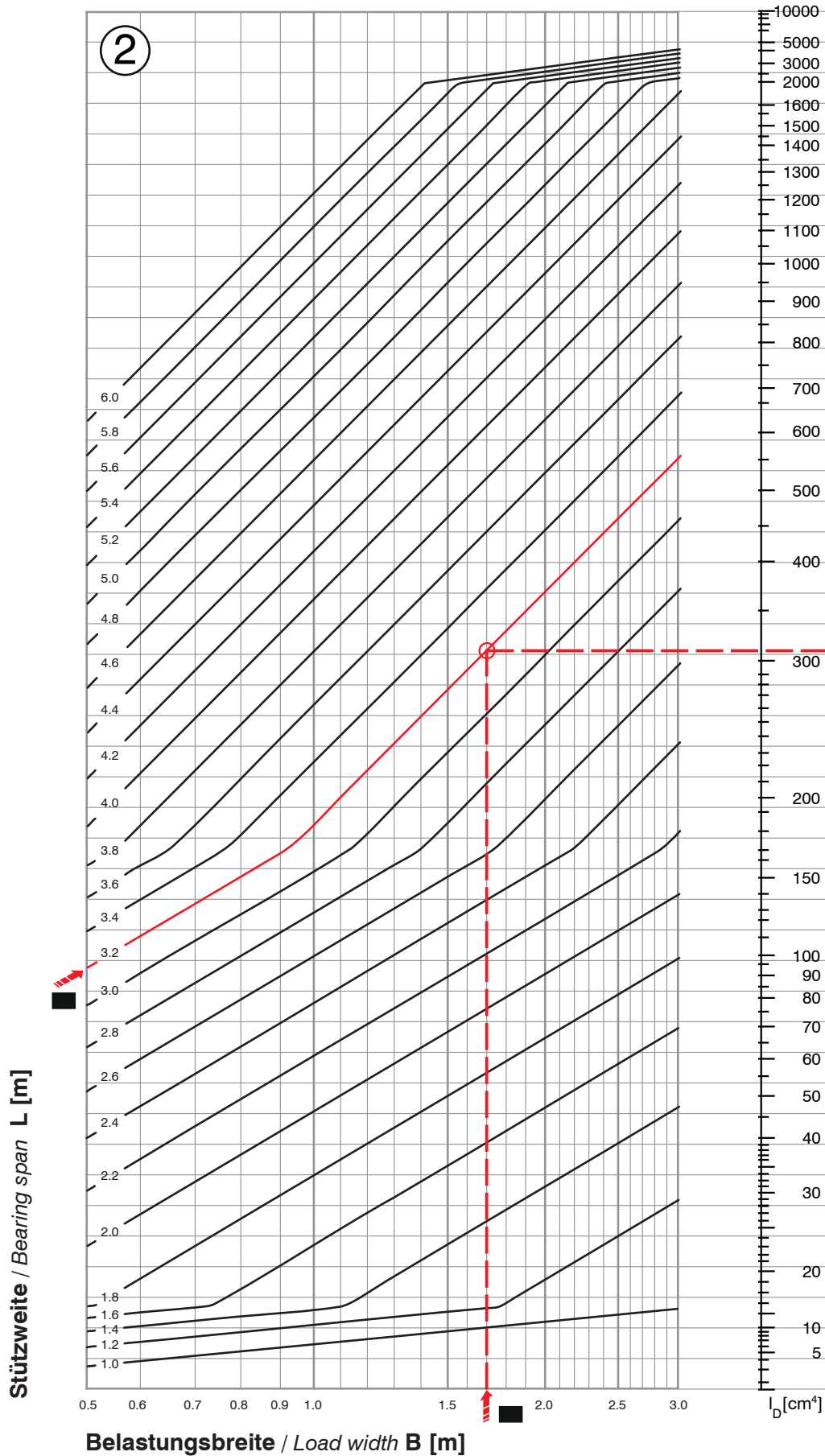

Rechtecklast (Einheitslast 1.0 kN/m²)
Rectangular load (Unit load 1.0 kN/m²)

$$f_{\text{zul. / adm.}} = L / 300$$

System / System

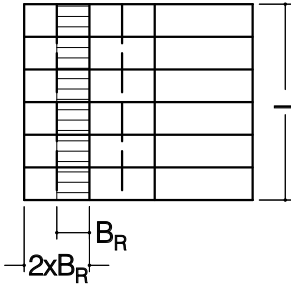

Anwendungsbeispiel Rechtecklast Example of application rectangular load

Stützweite / Bearing span:

$$L = 3.20 \text{ m}$$

Belastungsbreite / Load width:

$$B = 1.70 \text{ m}$$

Rechtecklast / Rectangular load:

$$I_D = 311 \text{ cm}^4 \text{ (Ⓢ abgelesen / is read)}$$

Ermittlung: erf. I_x / Determination: requ. I_x

Beispiel / Example:

Winddruck angenommen* / Wind pressure assumed*

$$= 0.64 \text{ kN/m}^2$$

$$\text{erf. / requ. } I_x = w_e \cdot I_D = 0.64 \cdot 311 \text{ cm}^4$$

$$= 199 \text{ cm}^4$$

Windsog angenommen* / Wind suction assumed*

$$= -1.12 \text{ kN/m}^2$$

$$\text{erf. / requ. } I_x = w_e \cdot I_D = (-1.12) \cdot 311 \text{ cm}^4$$

$$= 348.3 \text{ cm}^4$$

*die Windlast muß nach den gültigen Normen und nach Standort und Form des Gebäudes ermittelt werden.

*the wind suction must be determined according to the valid standards and to the position and shape of the building.

Statisches System Rechtecklast

Statical system rectangular load

Träger auf 2 Stützen / Beam on 2 supports

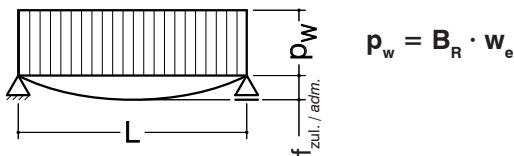

Berechnungsformel Rechtecklast

Calculation formula rectangular load

$$I_x = \frac{5 \cdot p_w \cdot L^4}{384 \cdot E \cdot f_{\text{zul. / adm.}}}$$

I_x	(cm ⁴) =	Trägheitsmoment / Moment of inertia
I_D	(cm ⁴) =	Trägheitsmoment, Rechtecklast / Moment of inertia, rectangular load
L	(cm) =	Stützweite / Bearing span
B	(cm) =	Belastungsbreite / Load width
w_e	(kN/cm ²) =	Winddruck/Windsog / Wind pressure/-depression
p_w	(kN/cm) =	Linienlast / Line load
E	(kN/cm ²) =	Elastizitätsmodul / Modulus of elasticity $7 \cdot 10^3$
$f_{\text{zul. / adm.}}$	(cm) =	zul. Durchbiegung / adm. deflection

$$f_{zul. / adm.} = L / 300 \text{ max. } 8 \text{ mm}$$

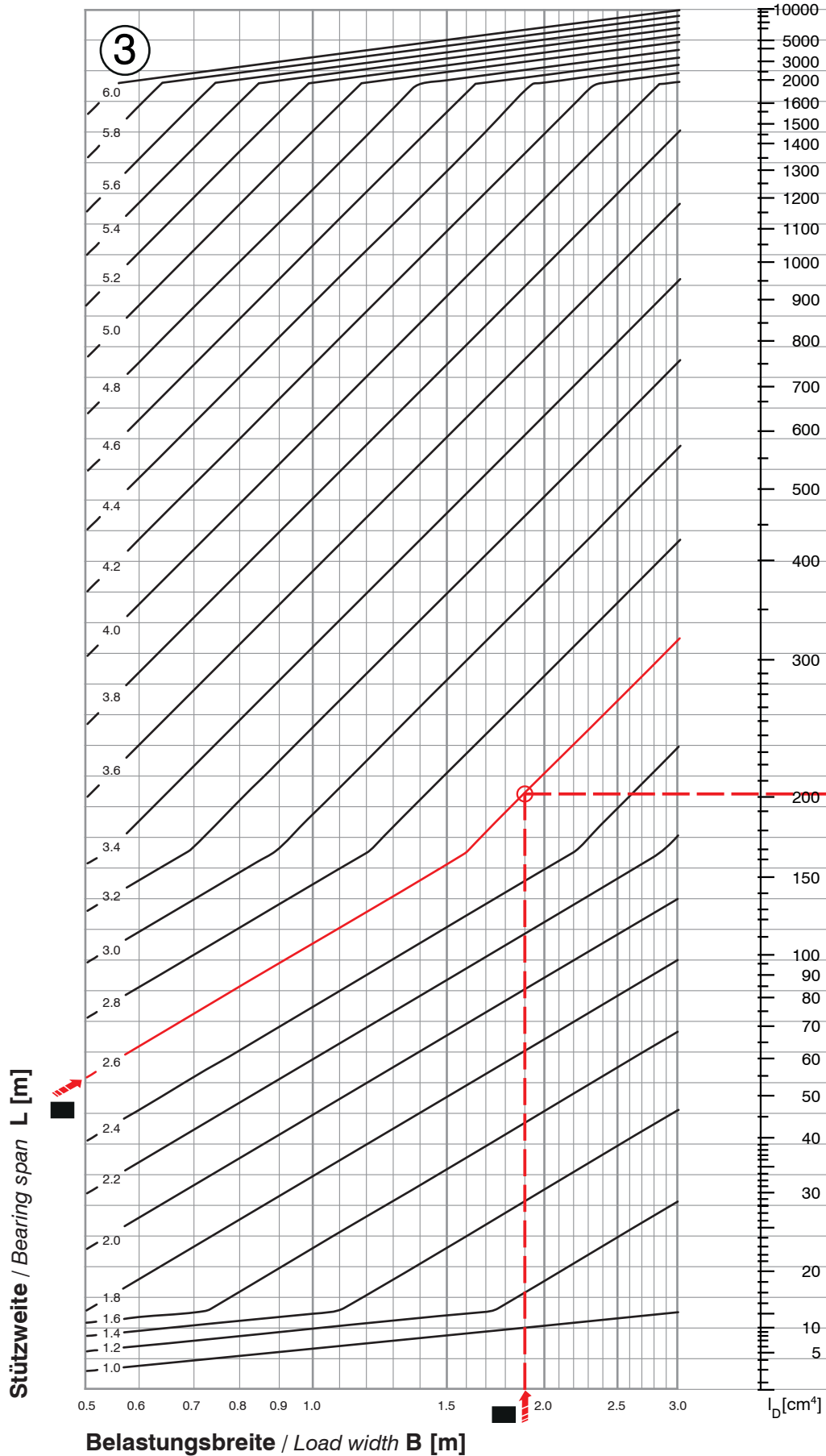

Rechtecklast (Einheitslast 1.0 kN/m²)
Rectangular load (Unit load 1.0 kN/m²)

$$f_{\text{zul. / adm.}} = L / 300 \text{ max. } 8 \text{ mm}$$

System / System

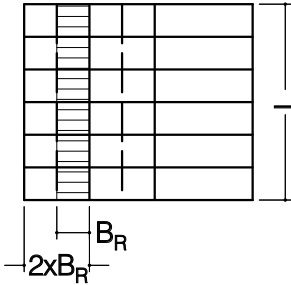

Anwendungsbeispiel Rechtecklast Example of application rectangular load

Stützweite / Bearing span:

$$L = 2.60 \text{ m}$$

Belastungsbreite / Load width:

$$B = 1.90 \text{ m}$$

Rechtecklast / Rectangular load :

$$I_D = 202 \text{ cm}^4 \text{ (} \textcircled{3} \text{ abgelesen / is read)}$$

Ermittlung: erf. I_x / Determination: requ. I_x

Beispiel / Example:

Winddruck angenommen* / Wind pressure assumed*
= 0.64 kN/m²

$$\text{erf. / requ. } I_x = w_e \cdot I_D = 0.64 \cdot 202 \text{ cm}^4 \\ = 129.3 \text{ cm}^4$$

Windsog angenommen* / Wind suction assumed*
= -1.12 kN/m²

$$\text{erf. / requ. } I_x = w_e \cdot I_D = (-1.12) \cdot 202 \text{ cm}^4 \\ = 226.2 \text{ cm}^4$$

*die Windlast muß nach den gültigen Normen und nach Standort und Form des Gebäudes ermittelt werden.

*the wind suction must be determined according to the valid standards and to the position and shape of the building.

Statisches System Rechtecklast

Statical system rectangular load

Träger auf 2 Stützen / Beam on 2 supports

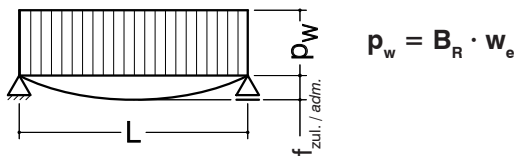

Berechnungsformel Rechtecklast

Calculation formula rectangular load

$$I_x = \frac{5 \cdot p_w \cdot L^4}{384 \cdot E \cdot f_{\text{zul. / adm.}}}$$

I_x	(cm ⁴) =	Trägheitsmoment / Moment of inertia
I_D	(cm ⁴) =	Trägheitsmoment, Rechtecklast / Moment of inertia, rectangular load
L	(cm) =	Stützweite / Bearing span
B	(cm) =	Belastungsbreite / Load width
w_e	(kN/cm ²) =	Winddruck/Windsog / Wind pressure/-depression
p_w	(kN/cm) =	Linienlast / Line load
E	(kN/cm ²) =	Elastizitätsmodul / Modulus of elasticity $7 \cdot 10^3$
$f_{\text{zul. / adm.}}$	(cm) =	zul. Durchbiegung / adm. deflection

Dreieck- und Trapezlast (Einheitslast 1.0 kN/m²)
Triangular and trapezoidal load (Unit load 1.0 kN/m²)

$$f_{zul. / adm.} = L / 200$$

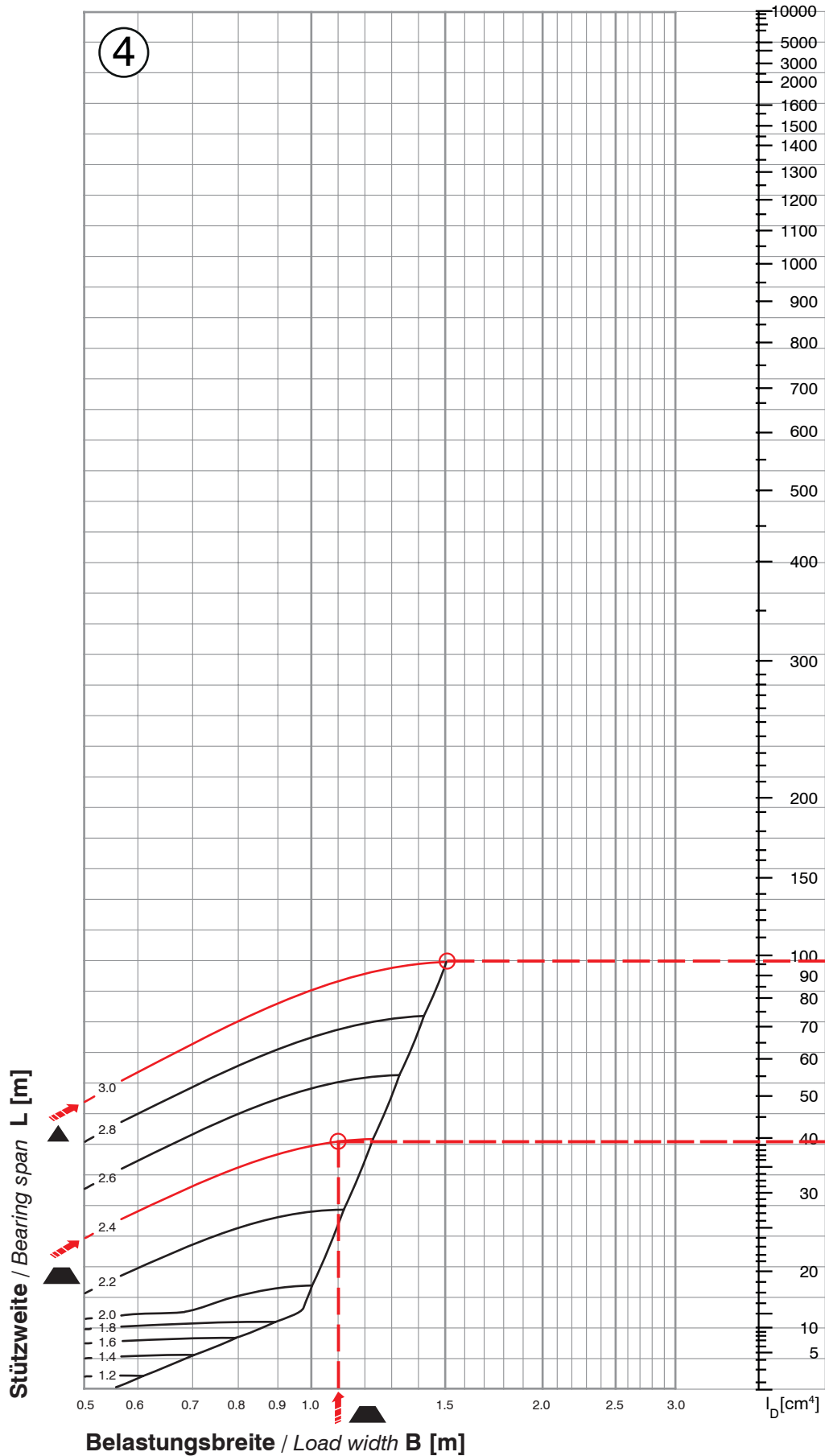

Dreieck- und Trapezlast (Einheitslast 1.0 kN/m²)
Triangular and trapezoidal load (Unit load 1.0 kN/m²)

$$f_{zul./adm.} = L / 200$$

System / System

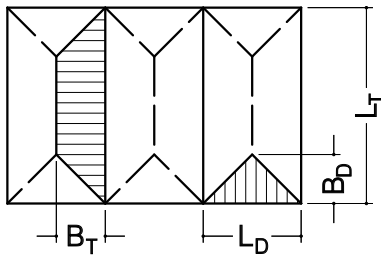

Anwendungsbeispiel Trapezlast

Example of application trapezoidal load

Stützweite / Bearing span:

$$L_T = 2.40 \text{ m}$$

Belastungsbreite / Load width:

$$B_T = 1.10 \text{ m}$$

Rechtecklast / Rectangular load:

$$I_D = 39 \text{ cm}^4 \text{ (④ abgelesen / is read)}$$

Statisches System Trapezlast

Statical system trapezoidal load

Träger auf 2 Stützen / Beam on 2 supports

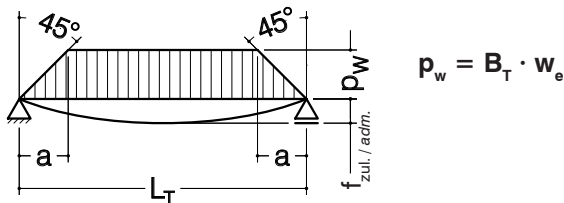

Ermittlung: erf. I_x / Determination: requ. I_x

Beispiel / Example:

Winddruck angenommen* / Wind pressure assumed*

$$= 0.64 \text{ kN/m}^2$$

erf. / requ. $I_x = w_e \cdot I_D = 0.64 \cdot 39 \text{ cm}^4$

$$= 25.0 \text{ cm}^4$$

Berechnungsformel Trapezlast

Calculation formula trapezoidal load

$$I_{xT} = \frac{p_w \cdot L_T^4}{1920 \cdot E \cdot f_{zul./adm.}} \cdot \left(25 - 40 \frac{a^2}{L_T^2} + 16 \frac{a^4}{L_T^4} \right)$$

Windsog angenommen* / Wind suction assumed*

$$= -1.12 \text{ kN/m}^2$$

erf. / requ. $I_x = w_e \cdot I_D = (-1.12) \cdot 39 \text{ cm}^4$

$$= 43.7 \text{ cm}^4$$

Statisches System Dreiecklast

Statical system triangular load

Träger auf 2 Stützen / Beam on 2 supports

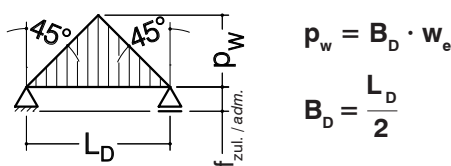

$$p_w = B_D \cdot w_e$$

$$B_D = \frac{L_D}{2}$$

Berechnungsformel Dreiecklast

Calculation formula triangular load

$$I_{xD} = \frac{p_w \cdot L^4}{120 \cdot E \cdot f_{zul./adm.}}$$

I_x (cm⁴) = Trägheitsmoment / Moment of inertia

L_D (cm) = Stützweite Dreiecklast / Bearing span triangular load

L_T (cm) = Stützweite Trapezlast / Bearing span trapezoidal load

B_D (cm) = Belastungsbreite Dreiecklast / Load width triangular load $B_D = L_D/2$

B_T (cm) = Belastungsbreite Trapezlast / Load width trapezoidal load

w_e (kN/cm²) = Winddruck/Windsog / Wind pressure/-depression

p_w (kN/cm) = Linienlast / Line load

E (kN/cm²) = Elastizitätsmodul / Modulus of elasticity $7 \cdot 10^3$

$f_{zul./adm.}$ (cm) = zul. Durchbiegung / adm. deflection

Dreieck- und Trapezlast (Einheitslast 1.0 kN/m²)
Triangular and trapezoidal load (Unit load 1.0 kN/m²)

$$f_{zul. / adm.} = L / 300$$

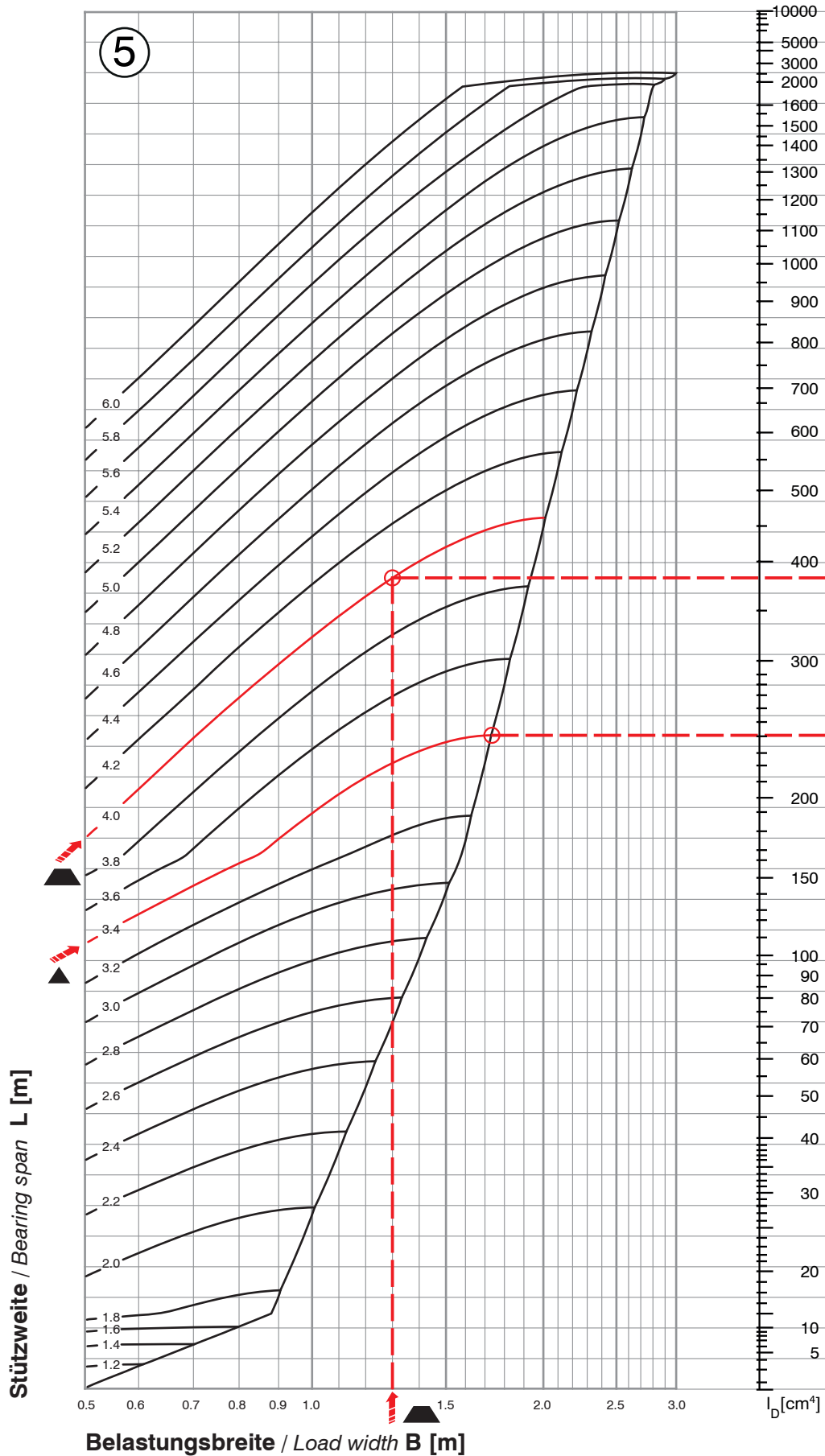

Dreieck- und Trapezlast (Einheitslast 1.0 kN/m²)
Triangular and trapezoidal load (Unit load 1.0 kN/m²)

$$f_{zul./adm.} = L / 300$$

System / System

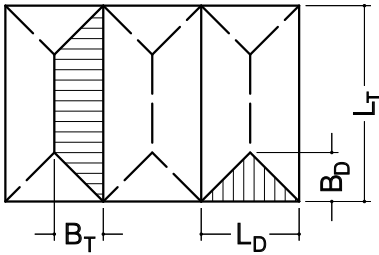

Anwendungsbeispiel Trapezlast

Example of application trapezoidal load

Stützweite / Bearing span:

$$L_T = 4.00 \text{ m}$$

Belastungsbreite / Load width:

$$B_T = 1.30 \text{ m}$$

Rechtecklast / Rectangular load:

$$I_D = 389 \text{ cm}^4 \text{ (Ⓢ abgelesen / is read)}$$

Statisches System Trapezlast

Statical system trapezoidal load

Träger auf 2 Stützen / Beam on 2 supports

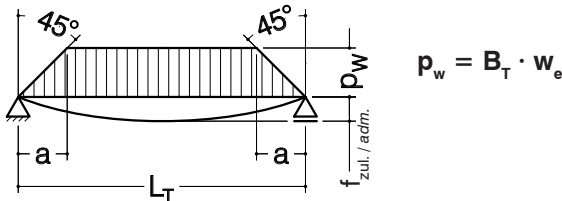

$$p_w = B_T \cdot w_e$$

Ermittlung: erf. I_x / Determination: requ. I_x

Beispiel / Example:

Winddruck angenommen* / Wind pressure assumed*

$$= 0.64 \text{ kN/m}^2$$

erf. / requ. $I_x = w_e \cdot I_D = 0.64 \cdot 389 \text{ cm}^4$

$$= 249.0 \text{ cm}^4$$

Berechnungsformel Trapezlast

Calculation formula trapezoidal load

$$I_{xT} = \frac{p_w \cdot L_T^4}{1920 \cdot E \cdot f_{zul./adm.}} \cdot \left(25 - 40 \frac{a^2}{L_T^2} + 16 \frac{a^4}{L_T^4} \right)$$

Windsog angenommen* / Wind suction assumed*

$$= -1.12 \text{ kN/m}^2$$

erf. / requ. $I_x = w_e \cdot I_D = (-1.12) \cdot 389 \text{ cm}^4$

$$= 435.7 \text{ cm}^4$$

Statisches System Dreiecklast

Statical system triangular load

Träger auf 2 Stützen / Beam on 2 supports

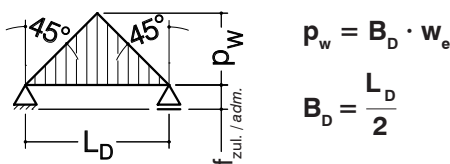

$$p_w = B_D \cdot w_e$$

$$B_D = \frac{L_D}{2}$$

Berechnungsformel Dreiecklast

Calculation formula triangular load

$$I_{xD} = \frac{p_w \cdot L^4}{120 \cdot E \cdot f_{zul./adm.}}$$

I_x (cm⁴) = Trägheitsmoment / Moment of inertia

I_D (cm⁴) = Trägheitsmoment, Rechtecklast / Moment of inertia, rectangular load

L_D (cm) = Stützweite Dreiecklast / Bearing span triangular load

L_T (cm) = Stützweite Trapezlast / Bearing span trapezoidal load

B_D (cm) = Belastungsbreite Dreiecklast / Load width triangular load $B_D = L_D/2$

B_T (cm) = Belastungsbreite Trapezlast / Load width trapezoidal load

w_e (kN/cm²) = Winddruck/Windsog / Wind pressure/-depression

p_w (kN/cm) = Linienlast / Line load

E (kN/cm²) = Elastizitätsmodul / Modulus of elasticity $7 \cdot 10^3$

$f_{zul./adm.}$ (cm) = zul. Durchbiegung / adm. deflection

WICSLIDE

Dreieck- und Trapezlast (Einheitslast 1.0 kN/m²)
 Triangular and trapezoidal load (Unit load 1.0 kN/m²)

Statikdiagramm Windlast
 Static diagram of wind load

$$f_{zul. / adm.} = L / 300 \text{ max. } 8 \text{ mm}$$

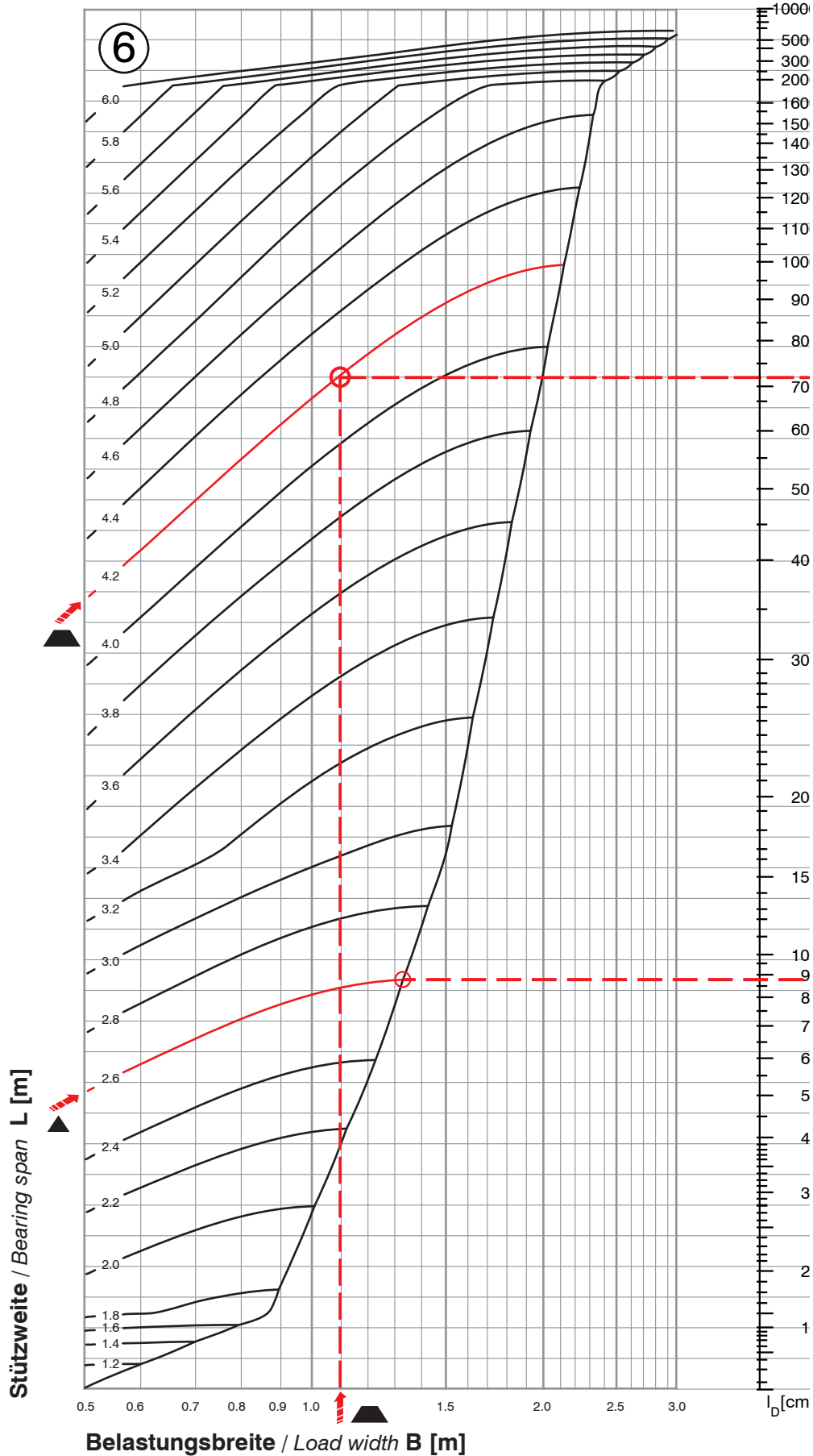

Dreieck- und Trapezlast (Einheitslast 1.0 kN/m²)
Triangular and trapezoidal load (Unit load 1.0 kN/m²)

$$f_{zul./adm.} = L / 300 \text{ max. } 8 \text{ mm}$$

System / System

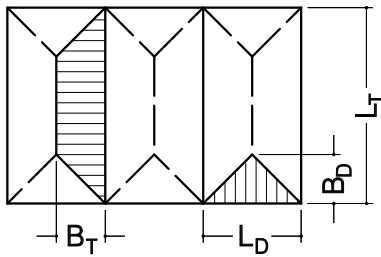

Anwendungsbeispiel Trapezlast

Example of application trapezoidal load

Stützweite / Bearing span:

$$L_T = 4.20 \text{ m}$$

Belastungsbreite / Load width:

$$B_T = 1.10 \text{ m}$$

Rechtecklast / Rectangular load:

$$I_D = 711 \text{ cm}^4 \text{ (} \textcircled{\text{C}} \text{ abgelesen / is read)}$$

Statisches System Trapezlast

Statical system trapezoidal load

Träger auf 2 Stützen / Beam on 2 supports

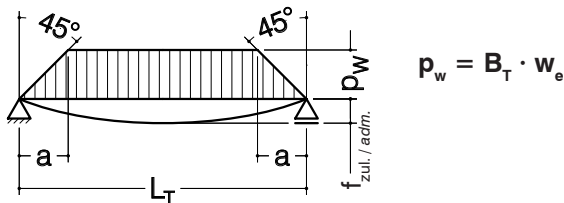

$$p_w = B_T \cdot w_e$$

Ermittlung: erf. I_x / Determination: requ. I_x

Beispiel / Example:

Winddruck angenommen* / Wind pressure assumed*

$$= 0.64 \text{ kN/m}^2$$

$$\text{erf. / requ. } I_x = w_e \cdot I_D = 0.64 \cdot 711 \text{ cm}^4$$

$$= 455.0 \text{ cm}^4$$

Berechnungsformel Trapezlast

Calculation formula trapezoidal load

$$I_{xT} = \frac{p_w \cdot L_T^4}{1920 \cdot E \cdot f_{zul./adm.}} \cdot \left(25 - 40 \frac{a^2}{L_T^2} + 16 \frac{a^4}{L_T^4} \right)$$

Windsog angenommen* / Wind suction assumed*

$$= -1.12 \text{ kN/m}^2$$

$$\text{erf. / requ. } I_x = w_e \cdot I_D = (-1.12) \cdot 711 \text{ cm}^4$$

$$= 796.3 \text{ cm}^4$$

Statisches System Dreiecklast

Statical system triangular load

Träger auf 2 Stützen / Beam on 2 supports

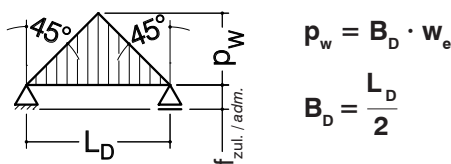

$$p_w = B_D \cdot w_e$$

$$B_D = \frac{L_D}{2}$$

Berechnungsformel Dreiecklast

Calculation formula triangular load

$$I_{xD} = \frac{p_w \cdot L^4}{120 \cdot E \cdot f_{zul./adm.}}$$

I_x (cm⁴) = Trägheitsmoment / Moment of inertia

I_D (cm⁴) = Trägheitsmoment, Rechtecklast / Moment of inertia, rectangular load

L_D (cm) = Stützweite Dreiecklast / Bearing span triangular load

L_T (cm) = Stützweite Trapezlast / Bearing span trapezoidal load

B_D (cm) = Belastungsbreite Dreiecklast / Load width triangular load $B_D = L_D/2$

B_T (cm) = Belastungsbreite Trapezlast / Load width trapezoidal load

w_e (kN/cm²) = Winddruck/Windsog / Wind pressure/-depression

p_w (kN/cm) = Linienlast / Line load

E (kN/cm²) = Elastizitätsmodul / Modulus of elasticity $7 \cdot 10^3$

$f_{zul./adm.}$ (cm) = zul. Durchbiegung / adm. deflection

WICSLIDE

Statikdiagramm Glaslast

Static diagram glass load

Glaslast (0.15 / 0.30 / 0.45 kN/m²)

Glass load (0.15 / 0.30 / 0.45 kN/m²)

$f_{zul. / adm.} = 3 \text{ mm}$

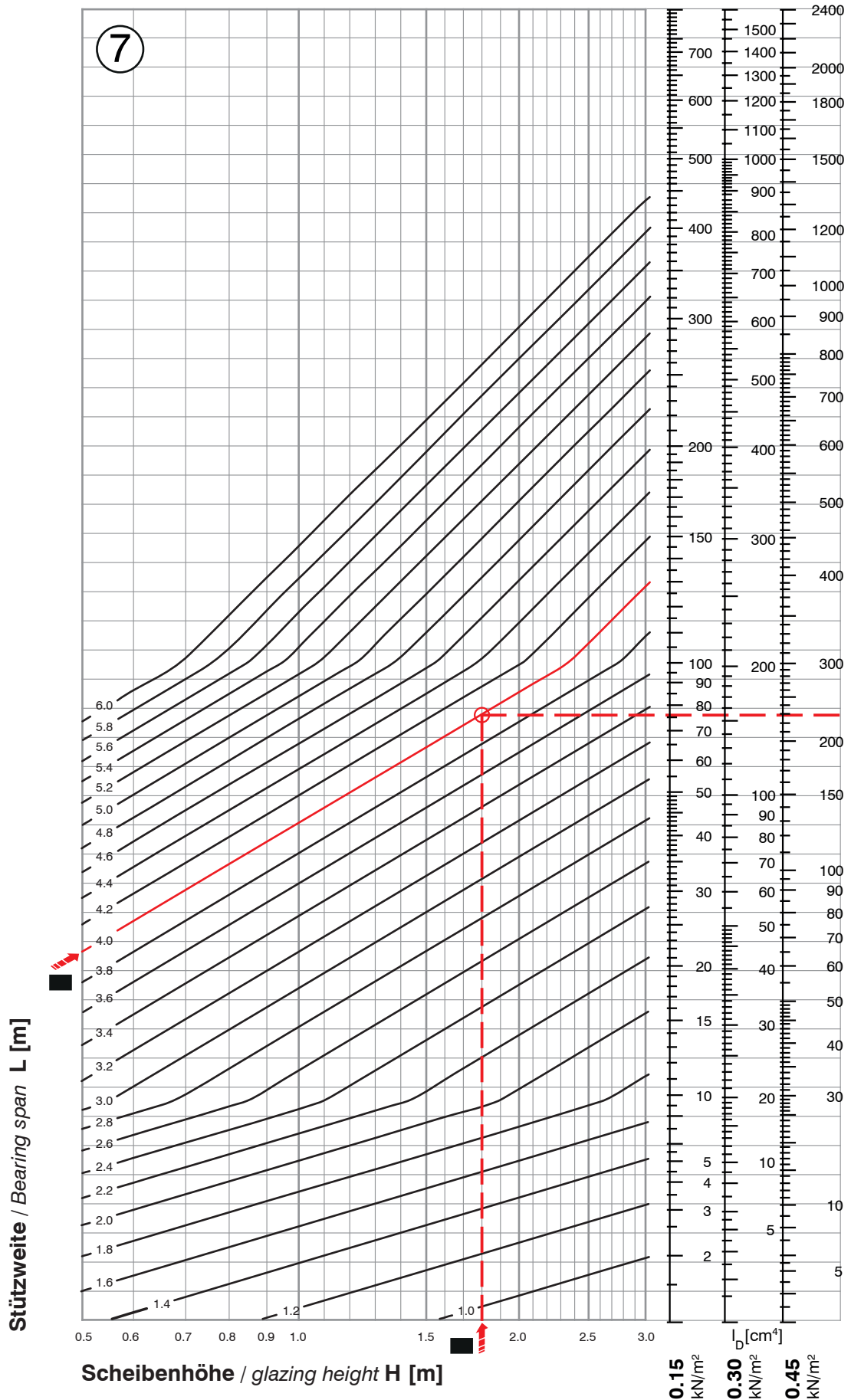

Glaslast (0.15 / 0.30 / 0.45 kN/m²)
Glass load (0.15 / 0.30 / 0.45 kN/m²)

$$f_{\text{zul. / adm.}} = 3 \text{ mm}$$

System / System

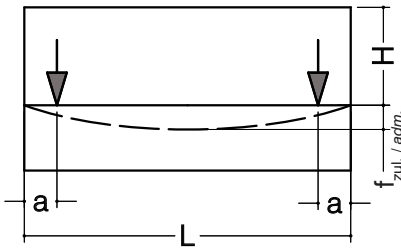

Das Eigengewicht des Profils ist nicht berücksichtigt!
The dead weight of the profile is not considered!

Anwendungsbeispiel Rechtecklast Example of application rectangular load

Stützweite / Bearing span:

$$L_T = 4.00 \text{ m}$$

Scheibenhöhe / Glazing height:

$$H = 1.80 \text{ m}$$

Statisches System Statical system

Träger auf 2 Stützen / Beam on 2 supports

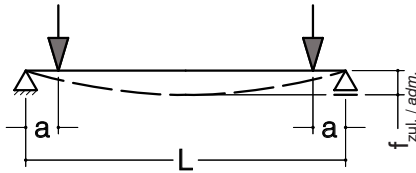

$$F = \frac{H \cdot L}{2} \cdot q_G$$

a = 150 mm festgelegt / fixed

Beispiel / Example:

bei / for q_G 0.15 kN/m²

$$I_y = 77 \text{ cm}^4 \text{ (⊗ abgelesen / is read)}$$

bei / for q_G 0.30 kN/m²

$$I_y = 154 \text{ cm}^4 \text{ (⊗ abgelesen / is read)}$$

bei / for q_G 0.45 kN/m²

$$I_y = 231 \text{ cm}^4 \text{ (⊗ abgelesen / is read)}$$

Berechnungsformel Glaslast Calculation formula glass load

Calculation formula glass load



$$I_y = \frac{F \cdot a}{24 \cdot E \cdot f_{\text{zul. / adm.}}} \cdot (3 \cdot L^2 - 4 a^2)$$



- I_y (cm⁴) = Trägheitsmoment / Moment of inertia
- $F(P)$ (kN) = Einzellast / Single load
- a (cm) = Klotzungsabstand / Shimming distance
- H (cm) = Scheibenhöhe / Pane height
- L (cm) = Stützweite / Bearing span
- q_G (kN/cm²) = Glasgewicht / Glass weight
- $f_{\text{zul. / adm.}}$ (cm) = zul. Durchbiegung / adm. deflection

WICSLIDE 160

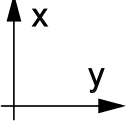
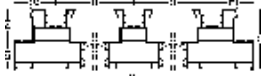
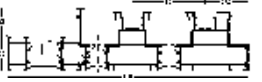
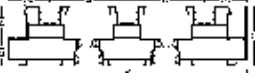
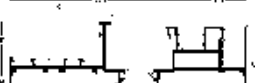
Blendrahmenprofile
Frame profiles

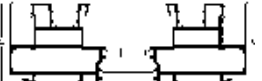
Statische Werte
Statical values

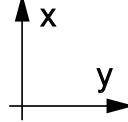
		Artikel-Nr. / Article-no.				
		lx	eff (cm ⁴) nach IfBt-Richtlinien eff (cm ⁴) acc. to IfBt guidelines			
		ly	add (cm ⁴) add (cm ⁴)			
		Stützweite L ab (cm) Bearing span L from (cm)				
		200	250	300	400	
		1040001				
		lx	0	0	0	0
		ly	37.99			
		1040002				
		lx	0	0	0	0
		ly	33.23			
		1040004				
		lx	0	0	0	0
		ly	39.04			
		1041344				
		lx	111.52	161.62	218.09	239.59
		ly	23.16			
		1041345				
		lx	149.08	182.08	206.96	239.52
		ly	27.39			
		1041346				
		lx	162.04	198.96	227.06	264.16
		ly	28.5			

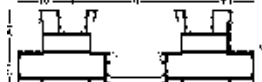
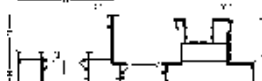
		Artikel-Nr. / Article-no.				
		lx	eff (cm ⁴) nach IfBt-Richtlinien eff (cm ⁴) acc. to IfBt guidelines			
		ly	add (cm ⁴) add (cm ⁴)			
		Stützweite L ab (cm) Bearing span L from (cm)				
		200	250	300	400	
		1041347				
		lx	138.96	201.53	231.56	269.55
		ly	34.87			
		1940006				
		lx	120.23	177.33	208.4	233.01
		ly	26.44			
		1940019				
		lx	0	0	0	0
		ly	21.68			

WICSLIDE 160

Flügelprofile
Sash profiles

Statische Werte
Statical values

Artikel-Nr. / Article-no.	
lx	eff (cm ⁴) nach IfBt-Richtlinien eff (cm ⁴) acc. to IfBt guidelines
ly	add (cm ⁴) add (cm ⁴)
Stützweite L ab (cm) Bearing span L from (cm)	
200 250 300 400	
1940037	
lx	30.35 35.37 38.86 43.09
ly	46.06

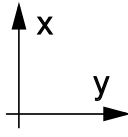
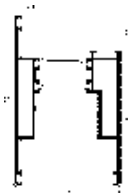
Artikel-Nr. / Article-no.	
lx	eff (cm ⁴) nach IfBt-Richtlinien eff (cm ⁴) acc. to IfBt guidelines
ly	add (cm ⁴) add (cm ⁴)
Stützweite L ab (cm) Bearing span L from (cm)	
200 250 300 400	

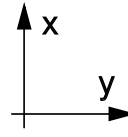

WICSLIDE 160

Kämpfer-, Sprossenprofile
Transom, glazing bar profiles

Statische Werte
Statical values

Artikel-Nr. / Article-no.	
lx	eff (cm ⁴) nach IfBt-Richtlinien eff (cm ⁴) acc. to IfBt guidelines
ly	add (cm ⁴) add (cm ⁴)
Stützweite L ab (cm) Bearing span L from (cm)	
200 250 300 400	

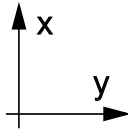
	
1916203	
lx	19.46 21.69 23.13 24.76
ly	12.13

Artikel-Nr. / Article-no.	
lx	eff (cm ⁴) nach IfBt-Richtlinien eff (cm ⁴) acc. to IfBt guidelines
ly	add (cm ⁴) add (cm ⁴)
Stützweite L ab (cm) Bearing span L from (cm)	
200 250 300 400	

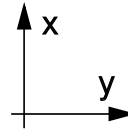
	
lx	19.46 21.69 23.13 24.76
ly	12.13

WICSLIDE 160

Pfostenprofile
Mullion profiles

Statische Werte
Statical values

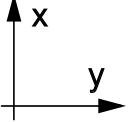
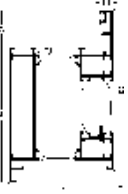
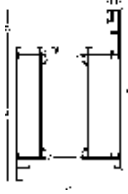
		Artikel-Nr. / Article-no.				
		lx	eff (cm ⁴) nach IfBt-Richtlinien eff (cm ⁴) acc. to IfBt guidelines			
ly	add (cm ⁴) add (cm ⁴)					
	Stützweite L ab (cm) Bearing span L from (cm)					
		200	250	300	400	
		1040010				
		lx	33.45	39.6	43.99	49.45
		ly	66.64			
		1940041				
		lx	33.86	39.74	43.87	48.93
		ly	72.79			

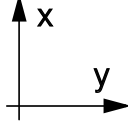
		Artikel-Nr. / Article-no.			
		lx	eff (cm ⁴) nach IfBt-Richtlinien eff (cm ⁴) acc. to IfBt guidelines		
ly	add (cm ⁴) add (cm ⁴)				
	Stützweite L ab (cm) Bearing span L from (cm)				
		200	250	300	400

WICSLIDE 160

Kupplungsprofile
Coupling profiles

Statische Werte
Statical values

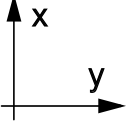
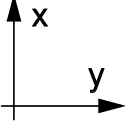
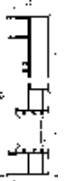
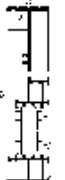
		Artikel-Nr. / Article-no.				
		lx	eff (cm ⁴) nach IfBt-Richtlinien eff (cm ⁴) acc. to IfBt guidelines			
		ly	add (cm ⁴) add (cm ⁴)			
		Stützweite L ab (cm) Bearing span L from (cm)				
			200	250	300	400
		1041331				
		lx	155.11	170.41	180.06	190.81
		ly	4.86			
		1041339				
		lx	136.62	154.07	165.56	178.81
		ly	4.66			

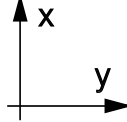
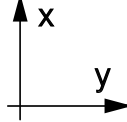
		Artikel-Nr. / Article-no.				
		lx	eff (cm ⁴) nach IfBt-Richtlinien eff (cm ⁴) acc. to IfBt guidelines			
		ly	add (cm ⁴) add (cm ⁴)			
		Stützweite L ab (cm) Bearing span L from (cm)				
			200	250	300	400

WICSLIDE 160

Zusatzprofile
Additional profiles

Statische Werte
Statical Values

Artikel-Nr. / Article-no.			
lx	add (cm ⁴)	Wx	add (cm ³)
ly	add (cm ⁴)	Wy	add (cm ³)

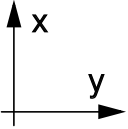

Artikel-Nr. / Article-no.			
lx	add (cm ⁴)	Wx	add (cm ³)
ly	add (cm ⁴)	Wy	add (cm ³)

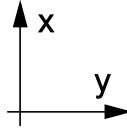

3090063			
lx	91.15	Wx	13.3
ly	7	Wy	4.19

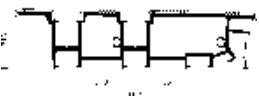

3090194			
lx	52.65	Wx	12.4
ly	21.23	Wy	9.43

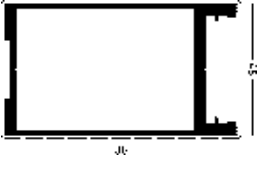

3091058			
lx	30.56	Wx	8.2
ly	13.4	Wy	7.44

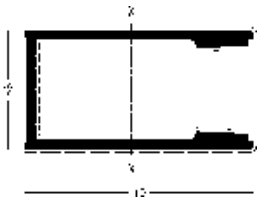

3940009			
lx	16.79	Wx	3.88
ly	0.78	Wy	0.36

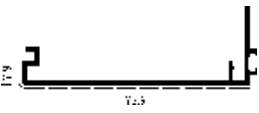













3940010			
lx	65.15	Wx	10.28
ly	1.08	Wy	0.49



WICSLIDE 160

Eckwinkelzuschnitt / Auswahltabellen
Cutting corner angle / Selection tables

			
Profil-Nr. Profil-No.			
<input checked="" type="checkbox"/> 1040001	3900006	55.6 mm	5930014
<input type="checkbox"/>	3900006	55.6 mm	5930014
1040002	3900007	13.2 mm	5930014
	3900006	55.6 mm	5930014
1040004	3900006	55.6 mm	5030075
	3900006	55.6 mm	5030075
1041344	3900006	55.6 mm	5030075
	3900006	55.6 mm	5030075
1041345	3900006	55.6 mm	5030075
	3900006	55.6 mm	5030075
1041346	3900006	55.6 mm	5030075
	3900006	55.6 mm	5030075
1041347	3900006	55.6 mm	5930014
	3900006	55.6 mm	5930014
1916203	3900007	13.2 mm	5930001
	3900007	13.2 mm	5930001
1940006	3900006	55.6 mm	5930014
	3900006	55.6 mm	5930014
1940019	3900007	13.2 mm	5930014
	3900006	55.6 mm	5930014
1940037	3900012	8.2 mm	5930013
	3900012	8.2 mm	5930013
1940037	3900012	8.2 mm	5930013
	3900012	8.2 mm	5930013

			
Profil-Nr. Profil-No.			
<input checked="" type="checkbox"/>			
<input type="checkbox"/>			



Lloyd's Register
LRQA

ZERTIFIKAT

Hiermit wird bescheinigt, dass das Qualitätsmanagementsystem von:

Sapa Building Systems GmbH
Einsteinstr. 61, 89077 Ulm
Deutschland

durch Lloyd's Register Quality Assurance geprüft und bewertet wurde und den folgenden Normen zum Qualitätsmanagement entspricht:

**ISO 9001:2008, EN ISO 9001:2008,
DIN EN ISO 9001:2008, SN EN ISO 9001:2008**

Das Qualitätsmanagementsystem ist anwendbar für:

**Entwicklung, Beschaffung und Vertrieb von Aluminiumprofilen
und -systemen für die Bauindustrie.**
**Lagerung, Kommissionierung, Bearbeitung und Distribution von
Aluminiumprofilen und Zubehör für die Fassaden, Fenster
und Türen. Test- und Prüfzentrum.**
Schulungen / Weiterbildung für Metallarbeiter.

Dieses Zertifikat ist nur in Verbindung mit dem Zertifikatsanhang gültig, wobei dieser Anhang mit den zugehörigen Niederlassungen die gleiche Referenznummer haben muss.

Zertifikat
Registrier-Nr.: KLN 0924020

Erstmalige Zulassung: 05. November 1993

Bestehendes Zertifikat: 18. Dezember 2014

Dieses Zertifikat ist gültig bis: 31. Oktober 2017

Ausgestellt von: Lloyd's Register Quality Assurance GmbH



Dieses Dokument unterliegt der unten stehenden Bestimmung.

Innere Kanalstr. 15, 50823 Köln, Deutschland, Handelsregister Nr. B 34587

Diese Zertifizierung wurde gemäß den LRQA-Verfahren zur Auditierung und Zertifizierung durchgeführt. Diese Verfahren werden von LRQA überwacht.

Macro Revision 14



Lloyd's Register
LRQA

CERTIFICATE OF APPROVAL

This is to certify that the Quality Management System of:

Sapa Building Systems GmbH
Einsteinstr. 61, 89077 Ulm
Germany

has been approved by Lloyd's Register Quality Assurance
to the following Quality Management System Standards:

ISO 9001:2008, EN ISO 9001:2008,
DIN EN ISO 9001:2008, SN EN ISO 9001:2008

The Quality Management System is applicable to:

**Design, procurement and sales of aluminium sections
and systems for the building and construction industry.**
**Stockholding, compiling, treatment and distribution of aluminium
sections and accessories for façades, windows and doors.**
Prototype build and Test Centre.
Training and education for metal builder.

This certificate is valid only in association with the certificate schedule bearing the
same number on which the locations applicable to this approval are listed.

Approval
Certificate No: KLN 0924020

Original Approval: 05 November 1993

Current Certificate: 18 December 2014

Certificate Expiry: 31 October 2017

Issued by: Lloyd's Register Quality Assurance GmbH



Innere Kanalstr. 15, 50823 Köln, Germany, Handelsregister Nr. B 34587
This approval is carried out in accordance with the LRQA assessment and certification procedures and monitored by LRQA.
Macro Revision 14

ZERTIFIKATSANHANG

Sapa Building Systems GmbH Einsteinstr. 61, 89077 Ulm Deutschland

Hauptsitz

Sapa Building Systems GmbH
Einsteinstr. 61
D-89077 Ulm

Tätigkeiten

Entwicklung, Beschaffung und Vertrieb
von Aluminiumprofilen und -systemen für
die Bauindustrie.

Niederlassungen

Technologiezentrum Bellenberg
Am Mühlholz 2
D-89287 Bellenberg

Tätigkeiten

Test- und Prüfzentrum.

Verkaufsbüro Nord-West
Business-Kontor im Hafen
Philosophenweg 31-33
D-47051 Duisburg

Verkauf.

Verkaufsbüro Mitte
Donnersberg Str. 1
D-64646 Heppenheim

Verkauf.

Verkaufsbüro Nord-Ost
Johann-Eck-Str. 2
D-04129 Leipzig

Verkauf.

Seite 1 von 2



Dieses Dokument unterliegt der unten stehenden Bestimmung.

Innere Kanalstr. 15, 50823 Köln, Deutschland, Handelsregister Nr. B 34587

Diese Zertifizierung wurde gemäß den LRQA-Verfahren zur Auditierung und Zertifizierung durchgeführt. Diese Verfahren werden von LRQA überwacht.

Macro Revision 14



Lloyd's Register
LRQA

CERTIFICATE SCHEDULE

Sapa Building Systems GmbH Einsteinstr. 61, 89077 Ulm Germany

Head Office

Sapa Building Systems GmbH
Einsteinstr. 61
D-89077 Ulm

Activities

Design, procurement and sales of aluminium sections and systems for the building and construction industry.

Locations

Technologiezentrum Bellenberg
Am Mühlholz 2
D-89287 Bellenberg

Activities

Prototype build and Test Centre.

Verkaufsbüro Nord-West
Business-Kontor im Hafen
Philosophenweg 31-33
D-47051 Duisburg

Sales.

Verkaufsbüro Mitte
Donnersberg Str. 1
D-64646 Heppenheim

Sales.

Verkaufsbüro Nord-Ost
Johann-Eck-Str. 2
D-04315 Leipzig

Sales.

Page 1 of 2



Innere Kanalstr. 15, 50823 Köln, Germany, Handelsregister Nr. B 34587

This approval is carried out in accordance with the LRQA assessment and certification procedures and monitored by LRQA.

Macro Revision 14

ZERTIFIKATSANHANG

Sapa Building Systems GmbH Einsteinstr. 61, 89077 Ulm Deutschland

Niederlassungen

Verkaufsbüro Süd
Einsteinstr. 61
D-89077 Ulm

Sapa Building Systems AG
Gewerbepark
CH-5506 Mägenwil

Sapa Building Systems GmbH
Servicecenter Gerstungen
In der Flur 1
D-99834 Gerstungen

Tätigkeiten

Verkauf.

Verkauf.

Lagerung, Kommissionierung, Bearbeitung
und Distribution von Aluminiumprofilen
und Zubehör für Fassaden, Fenster und
Türen.

Zertifikat
Registrier-Nr.: KLN 0924020

Erstmalige Zulassung: 05. November 1993

Bestehendes Zertifikat: 18. Dezember 2014

Dieses Zertifikat ist gültig bis: 31. Oktober 2017

Seite 2 von 2



Dieses Dokument unterliegt der unten stehenden Bestimmung.

Innere Kanalstr. 15, 50823 Köln, Deutschland, Handelsregister Nr. B 34587

Diese Zertifizierung wurde gemäß den LRQA-Verfahren zur Auditierung und Zertifizierung durchgeführt. Diese Verfahren werden von LRQA überwacht.

Macro Revision 14



Lloyd's Register
LRQA

CERTIFICATE SCHEDULE

Sapa Building Systems GmbH Einsteinstr. 61, 89077 Ulm Germany

Locations

Verkaufsbüro Süd
Einsteinstr. 61
D-89077 Ulm

Hydro Building Systems AG
Gewerbepark
CH-5506 Mägenwil

Hydro Building Systems GmbH
Servicecenter Gerstungen
In der Flur 1
D-99834 Gerstungen

Activities

Sales.

Sales.

Stockholding, compiling, treatment and distribution of aluminium sections and accessories for façades, windows and doors.

Approval
Certificate No: KLN 0924020

Original Approval: 05 November 1993

Current Certificate: 18 December 2014

Certificate Expiry: 31 October 2017

Page 2 of 2



Innere Kanalstr. 15, 50823 Köln, Germany, Handelsregister Nr. B 34587
This approval is carried out in accordance with the LRQA assessment and certification procedures and monitored by LRQA.

**Austria**

5201 Seekirchen
☎ +43 6212 2000
✉ info@wicona.at

Benelux

3400 Landen
☎ +32 11 690316
✉ info@wicona.be
✉ info@wicona.nl

Czech Republic

63900 Brno
☎ +420 543 422030
✉ info@wicona.cz

Denmark

8381 Tilst
☎ +45 70 20 20 48

España

08195 Sant Cugat del Vallès
Barcelona
☎ +34 902 222323
✉ info@wicona.es

Estonia / Latvia / Lithuania

11317, Tallinn
☎ +37 2657 6635
✉ info@wicona.lt

France

02200 Courmelles
☎ +33 3 23598200
✉ info@wicona.fr

94388 Bonneuil-sur-Marne Cedex
☎ +33 1 45138000

Germany

89077 Ulm
☎ +49 731 3984-0
✉ info@wicona.de

47051 Duisburg
☎ +49 203 45046-0

04315 Leipzig
☎ +49 341 989795-0

64646 Heppenheim
☎ +49 6252 6736-0

Hungary

1031 Budapest
☎ +36 (1) 4533457
✉ info@wicona.hu

Ireland

Dublin 22, Eire
☎ +353 1 4105766
✉ info@wicona.ie

Italia

20063 Cernusco sul Naviglio MI
☎ +39 02 924291
✉ info@wicona.it

Norway

2007 Kjeller
☎ +47 22 42 22 00
✉ wicona@wicona.no

Poland

03-828 Warszawa
☎ +48 22 3308170
✉ info@wicona.pl

Sweden

352 45 Växjö
☎ +46 470 78 74 00
✉ wicona@wicona.se

Switzerland

5506 Mägenwil
☎ +41 62 88741-41
✉ info@wicona.ch

United Kingdom

Wakefield WF5 9TG
☎ +44 845 6028799
✉ info@wicona.co.uk

Africa / Asia / America

31037 Toulouse
☎ +33 5 61312626
✉ info@wicona-int.com

China

Tongzhou District, Beijing, PRC 101102
☎ +8610 60595686
✉ info@wicona.cn

Qatar

Doha
☎ +974 44 912552
✉ info@wicona-int.com

