



# URBAN

GLASS BALCONY AND FACADE SOLUTIONS



HIGHLINE / AMSTERDAM, THE NETHERLANDS / REF. NO. 01327

## CONTENTS

COMFORTABLE LIVING SPACE	04
THE BENEFITS OF SOLARLUX SYSTEMS	06
THERMALLY INSULATED SYSTEMS	16
NON-INSULATED SYSTEMS	34
ACCESS BALCONY GLAZING	52
CERO BY SOLARLUX	58
REFERENCE PROJECTS	68
EVERYTHING FROM A SINGLE SOURCE	102
ABOUT SOLARLUX	112



HIGHLINE / AMSTERDAM, THE NETHERLANDS / REF. NO. 01327

## COMFORTABLE LIVING SPACE

### *Balcony glazing – The perfect solution*

Urban living space is more popular than ever. Finding suitable spaces for new apartment developments and keeping existing apartments attractive in noisy areas present new challenges for investors and landlords. As a result, sound insulation measures often take top priority when it comes to both renovations and new, upmarket construction projects. The desire to extend living spaces without giving up the balcony, weather protection, and energy-related factors also affect the planning process.

Durable, low-maintenance and needs-oriented Solarlux balcony glazing – available in both thermally insulated and non-insulated variants – fulfils the demand for a modern, easily rentable living space. The use of flexible glazing solutions creates high-quality, relaxing apartments, giving the property lasting protection against the prevailing competitive conditions – particularly in attractive, urban locations that pose special challenges.



SL 25 / LONDON, ENGLAND / REF. NO. 00821

# THE *Benefits* OF SOLARLUX SYSTEMS

UPGRADE YOUR PROPERTY  
AND LIVING SPACE

## SHELTERED BALCONIES

*Worthwhile investment for greater attractiveness*

An unobstructed view of the outdoors, living rooms flooded with light, and a space in the sun that can be used virtually year-round: glazed balconies are high on the wish list of every tenant and buyer. Optimum sound insulation, perfect shelter from the elements and balconies with maximum flexible usage, not only increase the attractiveness of a property, but also pay off in a tangible sense economically.



SL 35 / LEIDEN, THE NETHERLANDS / REF. NO. 00455



SL 35 / LEIDEN, THE NETHERLANDS / REF. NO. 00455



SL 25 XXL MODULAR / NEW BRIGHTON, ENGLAND / REF. NO. 01301



SL 25 MODULAR / HAMBURG, GERMANY / REF. NO. 01403



SL 25 / NEU-ULM, GERMANY / REF. NO. 01094



#### WIND & WEATHER PROTECTION

The use of Solarlux systems not only extends a home's living space - it also provides real location advantages. The flexible glazing solutions ensure perfect protection from the elements and allow you to enjoy your balcony for more often. Rain rolls off, the wind is kept out, and on sunny days, the glass elements can be opened up across the entire width of the balcony.



#### OPENING OPTIONS

Opening inwards or outwards, folding to the left and/or right, folding or sliding to the side - Solarlux systems offer a wide range of opening options. The individual elements can be opened across their entire width in just a few easy steps. Thanks to their sophisticated engineering, low-maintenance and stainless steel carriage, even large glass elements can be operated very easily and quietly. In addition to this, both the inside and outside are easy to clean.



#### SOUND INSULATION AND VENTILATION

Apartments on the outskirts of cities are more popular than ever, but noise levels often present a significant challenge in these areas. Solarlux balcony glazing ensures optimum sound insulation up to  $R_w$  45 dB, making living space on busy roads much more attractive. Solarlux systems also allow mechanical ventilation by means of trickle ventilation built into the glazing or by tilting the windows.

[LOOKING FOR MORE INFORMATION ABOUT SOUND INSULATION? ORDER OUR FLYER!](#)



#### THERMAL INSULATION AND ENERGY SAVINGS

Balcony and facade glazing is a sensible choice from an ecological point of view. Solarlux systems such as our bi-folding doors - which are also available in combination with our curtain-hung facade module as a parapet element - offer optimum thermal insulation. From the fulfilment of the latest regulations of the German Energy Savings Ordinance (EnEV) up to passive house standards, Solarlux provides the right system for you.



#### USER-FRIENDLINESS

All Solarlux systems are incredibly user-friendly. In addition to being put through their paces in durability tests by our in-house research and development team, they also provide technical details that make them easier to operate. For example, our bi-folding doors can be equipped with a cleaning pin with "Easy Clean Technology", which makes the outside of the panel easy to clean, even on top floors, and renders incorrect operation absolutely impossible.



SL 25 MODULAR / LEIPZIG, GERMANY / REF. NO. 01125



FIND OUT MORE ABOUT  
OUR BALCONY GLAZING  
SYSTEMS HERE





SL 60E MODULAR / PFORZHEIM, GERMANY / REF. NO. 00119

*Thermally  
insulated*  
**BALCONY  
AND FACADE  
SYSTEMS**

A BALCONY AS A BRIGHT LIVING SPACE

## *Open up rooms – expand rentable space*

Bi-folding doors are ideal for extending the rentable area of a home or transforming the living space into a pergola with a balcony aesthetic. The thermally insulated profiles with innovative glazing create a continuous facade, behind which the balcony becomes a living space. The key to this is the same for every application: the bi-folding door can be opened across its entire width, folding up like an accordion.

### **AT A GLANCE**

- Creates additional, fully rentable living space
- Wide openings maintain the balcony aesthetic in the room
- Sound insulation up to 45 dB when installed
- Quick installation thanks to prefabrication and easy adjustability, even with dimensional tolerances
- Curtain-hung facade as an option to prevent damage to the balcony slab



## ECOLINE AND HIGHLINE

*Aluminium, thermally insulated*

Despite their differences in building depth (67 mm and 84 mm), our two thermally insulated bi-folding door systems, Ecoline and Highline, both boast a slim sight line of 99 mm at the panel butt joint. The reason for this is the bionicTURTLE®: a multifunctional insulating bar that combines a number of technical details. Its shape helps to keep profiles extremely slim - even when using large and heavy panels. In addition to this, it also serves to accommodate locking mechanisms and fittings, and ensures perfect insulation.



**ECOLINE - TECHNICAL DATA**

- Overall panel depth: 67 mm
- Sight line in panel butt joint: 99 mm
- Glass thickness: 5 - 36 mm
- $U_w \geq 1.1 \text{ W/m}^2\text{K}$
- Panel width: Up to 1 m
- Panel height: Up to 3 m
- Panel weight: Up to 90 kg
- Accessible floor track available as an option
- RC2-certified

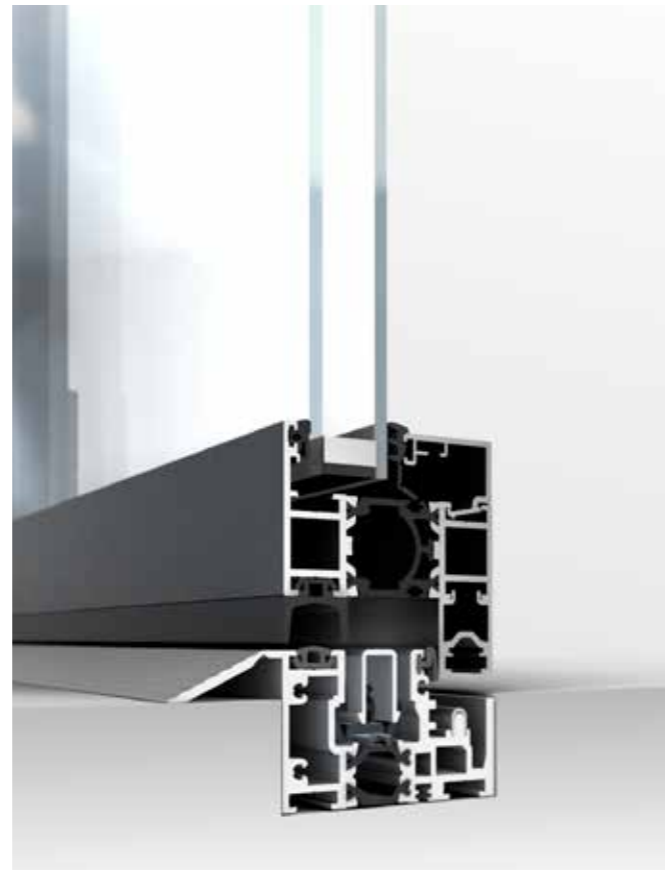
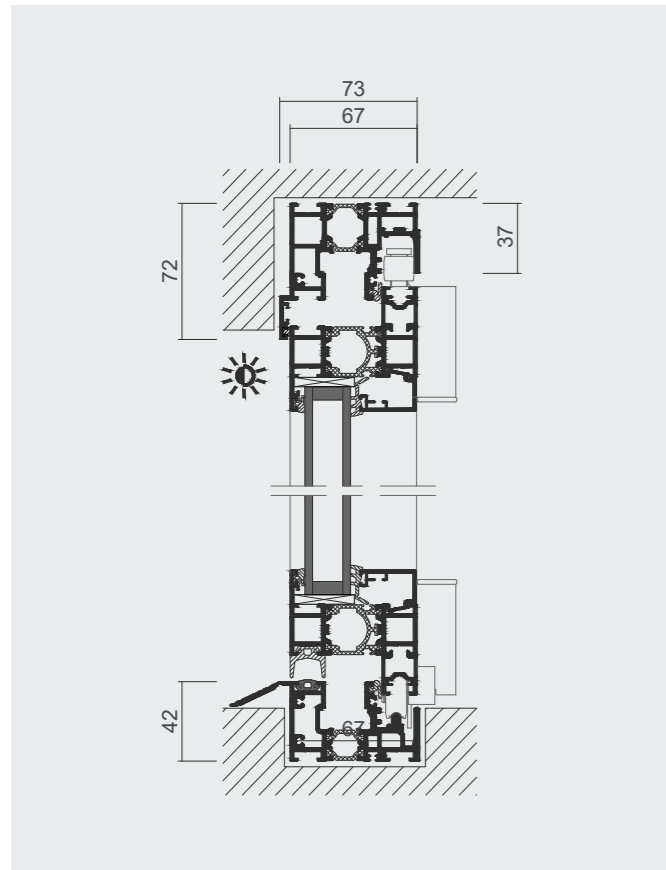
**HIGHLINE - TECHNICAL DATA**

- Overall panel depth: 84 mm
- Sight line in panel butt joint: 99 mm
- Glass thickness: 22 - 60 mm
- $U_w \geq 0.8 \text{ W / m}^2\text{K}$
- Panel width: Up to 1.1 m
- Panel height: Up to 3.5 m
- Panel weight: Up to 110 kg
- Accessible floor track available as an option
- RC2-certified

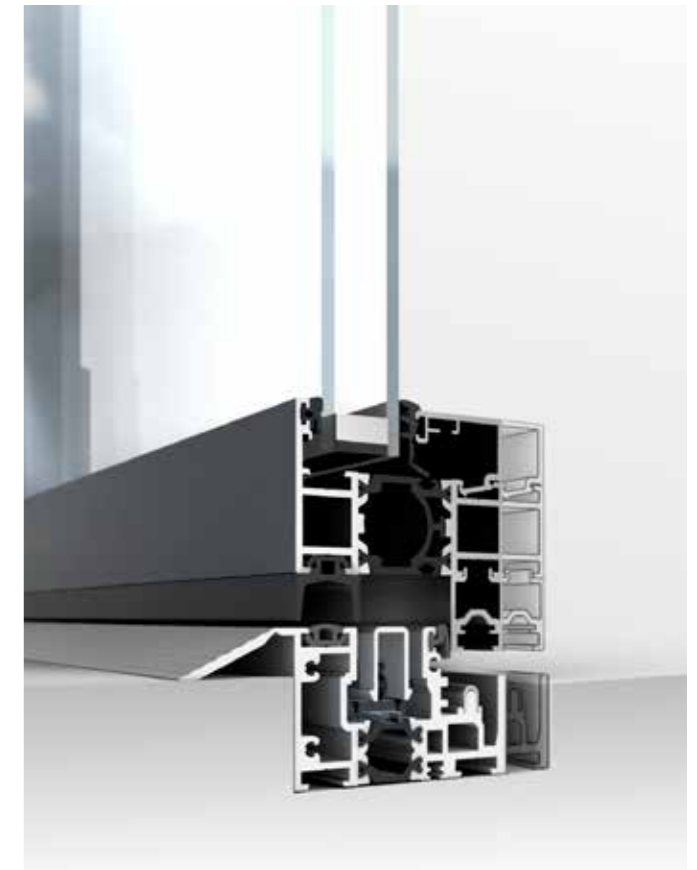
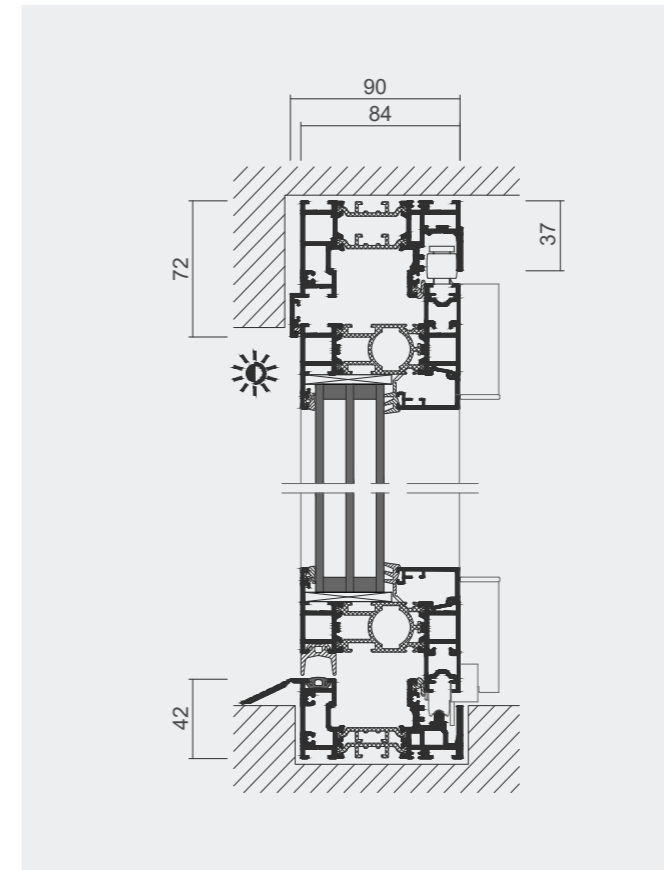



## WOODLINE

*Wood, thermally insulated*

Cosy yet modern: The Woodline bi-folding door is the perfect choice for those who want the best of both worlds. Its profiles consist of FSC® and PEFC™-certified quality wood with several laminated layers; a special corner joint between the panels guarantees additional stability. The sub-frame comprises an aluminium structure that is completely clad in solid-wood sections, inside and out.

## COMBILINE

*Wood/aluminium, thermally insulated*

Maximum weather resistance is guaranteed thanks to the edged aluminium cover on the wooden profile. The sub-frame comprises an aluminium structure that is faced with solid-wood sections on the inside of the frame. The seal encompasses two continuous sealing levels, so optimum drainage is guaranteed.

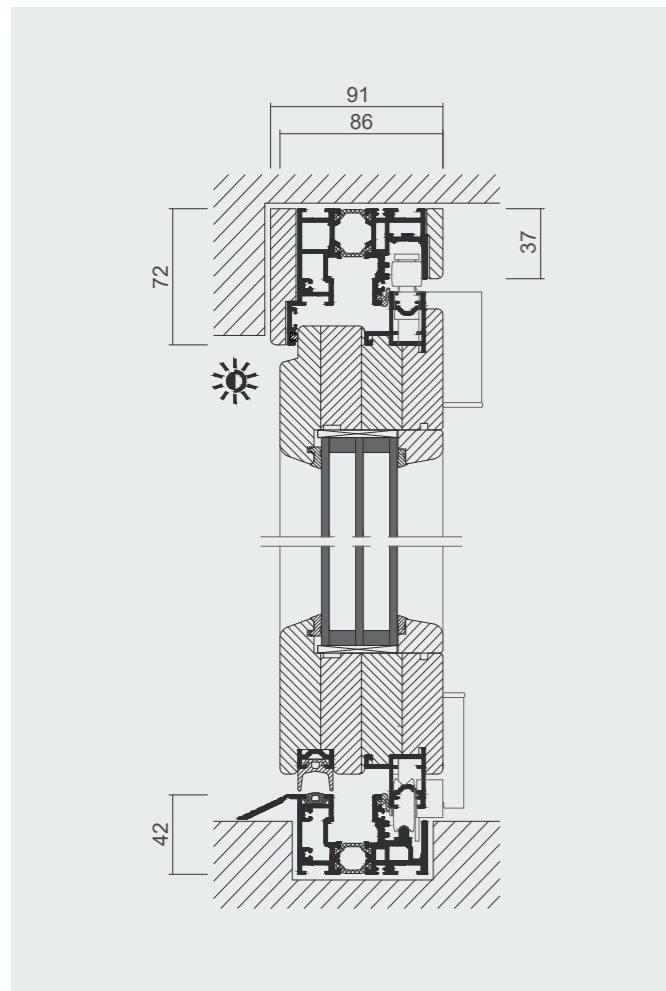

Photo: © Simon Menges

Photo: © Simon Menges

**WOODLINE - TECHNICAL DATA**

- Overall panel depth: 86 mm
- Sight line in panel butt joint: 143 mm
- Glass thickness: 28 - 48 mm
- $U_w \geq 1.0 \text{ W / m}^2\text{K}$
- Panel width: Up to 1 m
- Panel height: Up to 2.8 m
- Panel weight: Up to 100 kg
- Accessible floor track available as an option
- RC2-certified

**COMBILINE - TECHNICAL DATA**

- Overall panel depth: 86 mm
- Sight line in panel butt joint: 147 mm
- Glass thickness: 28 - 48 mm
- $U_w \geq 1.1 \text{ W / m}^2\text{K}$
- Panel width: Up to 1 m
- Panel height: Up to 2.8 m
- Panel weight: Up to 100 kg
- Accessible floor track available as an option
- Extremely high weather resistance, thanks to aluminium covers on the outside
- RC2-certified

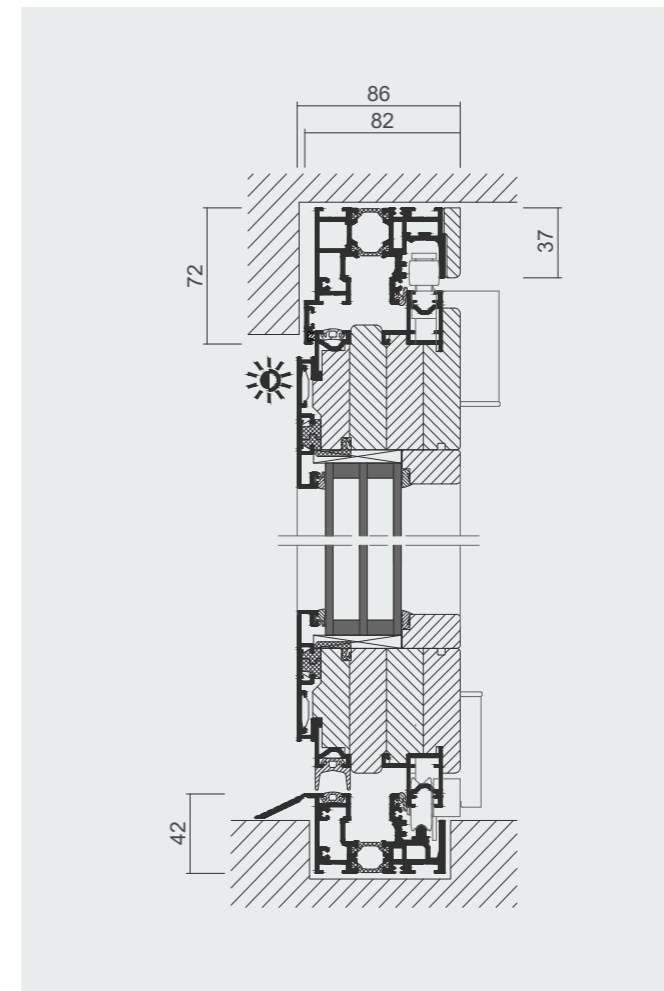

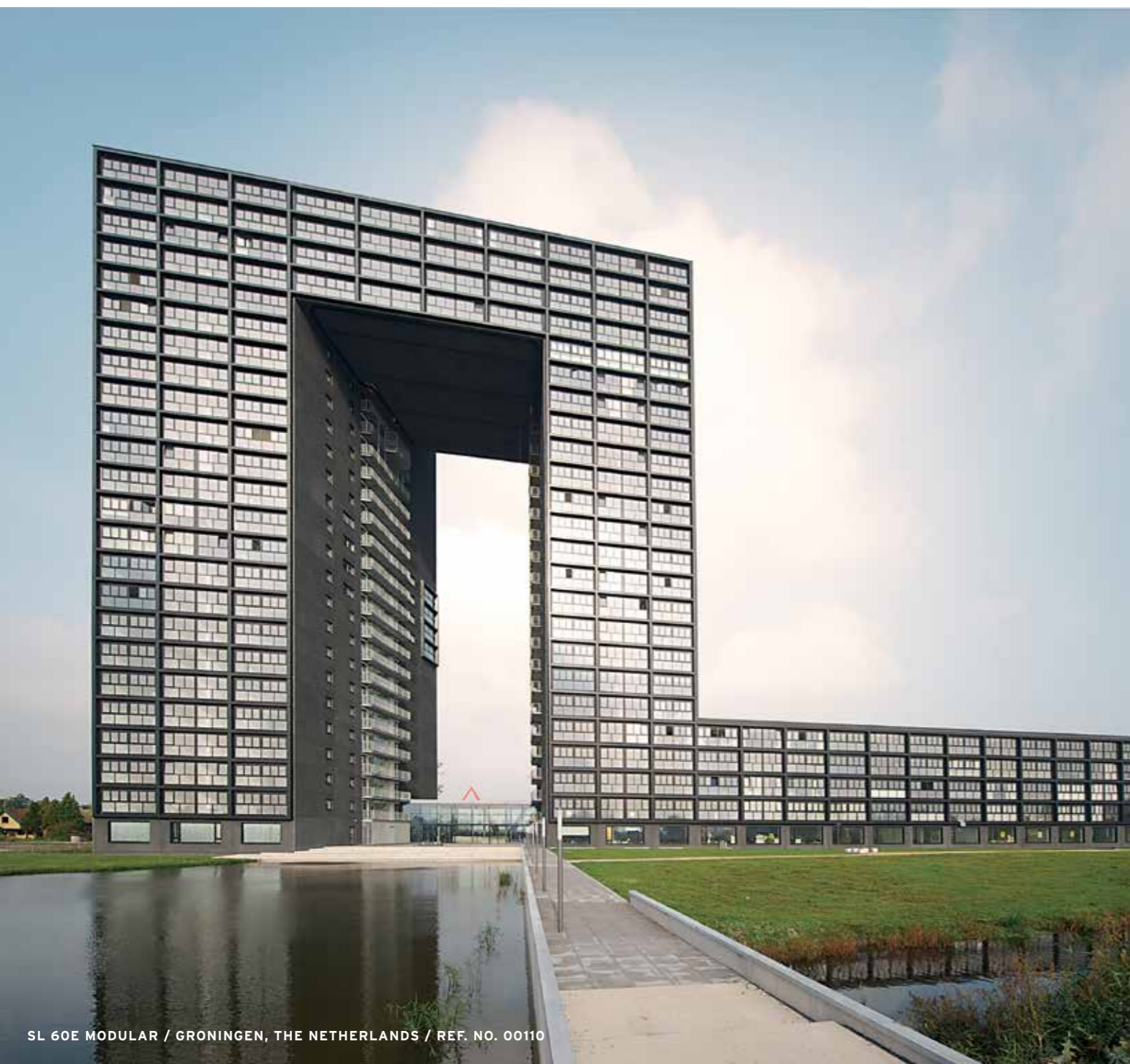

SL 60E MODULAR / GRONINGEN, THE NETHERLANDS / REF. NO. 00110



SL 60E MODULAR / GRONINGEN, THE NETHERLANDS / REF. NO. 00110

## SL MODULAR

*Facade, thermally insulated*

The SL Modular system is designed as a curtain-hung facade with integrated drainage, and combines a fixed parapet element with a flexible bi-folding door system of the customer's choice to form a unit. The SL Modular system offers many advantages. Thanks to the high degree of pre-fabrication it provides as a complete unit, only a relatively short installation time is required. When combined with a fully opening bi-folding door, it allows the fully-fledged, newly created living space to retain its balcony aesthetic.

**THE SL MODULAR COMBINES**  
**A FIXED BALUSTRADE**  
**ELEMENT WITH A FLEXIBLE**  
**BI-FOLDING DOOR**

**SL MODULAR - TECHNICAL DATA**

- Individual parapet design
- A visually appealing solution as a curtain-hung facade with integrated drainage
- No damage to the thermally insulated composite system
- Short installation time thanks to modular construction
- Combines with the Solarlux bi-folding door for the added advantage of top-quality living space

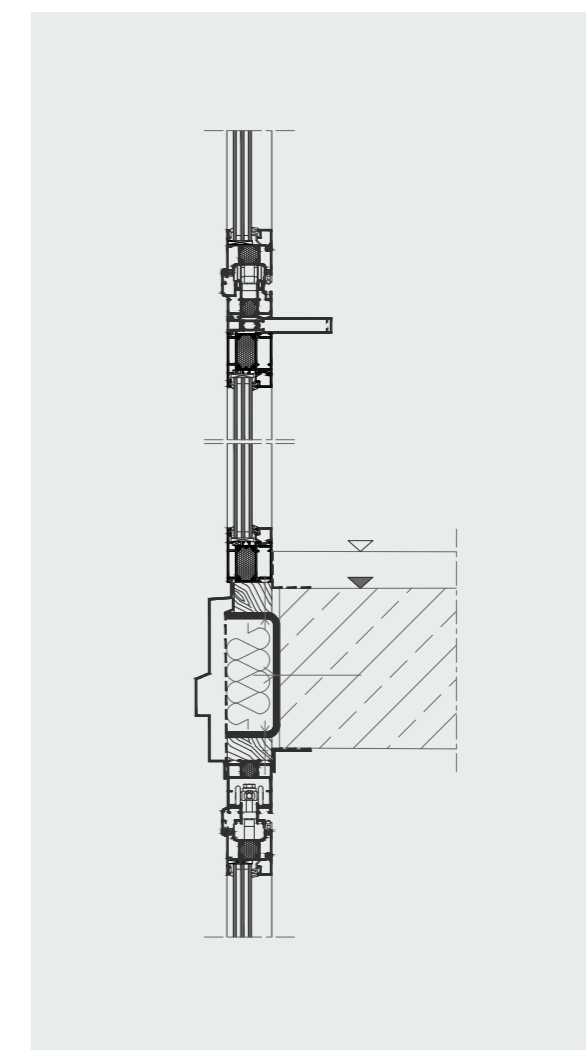
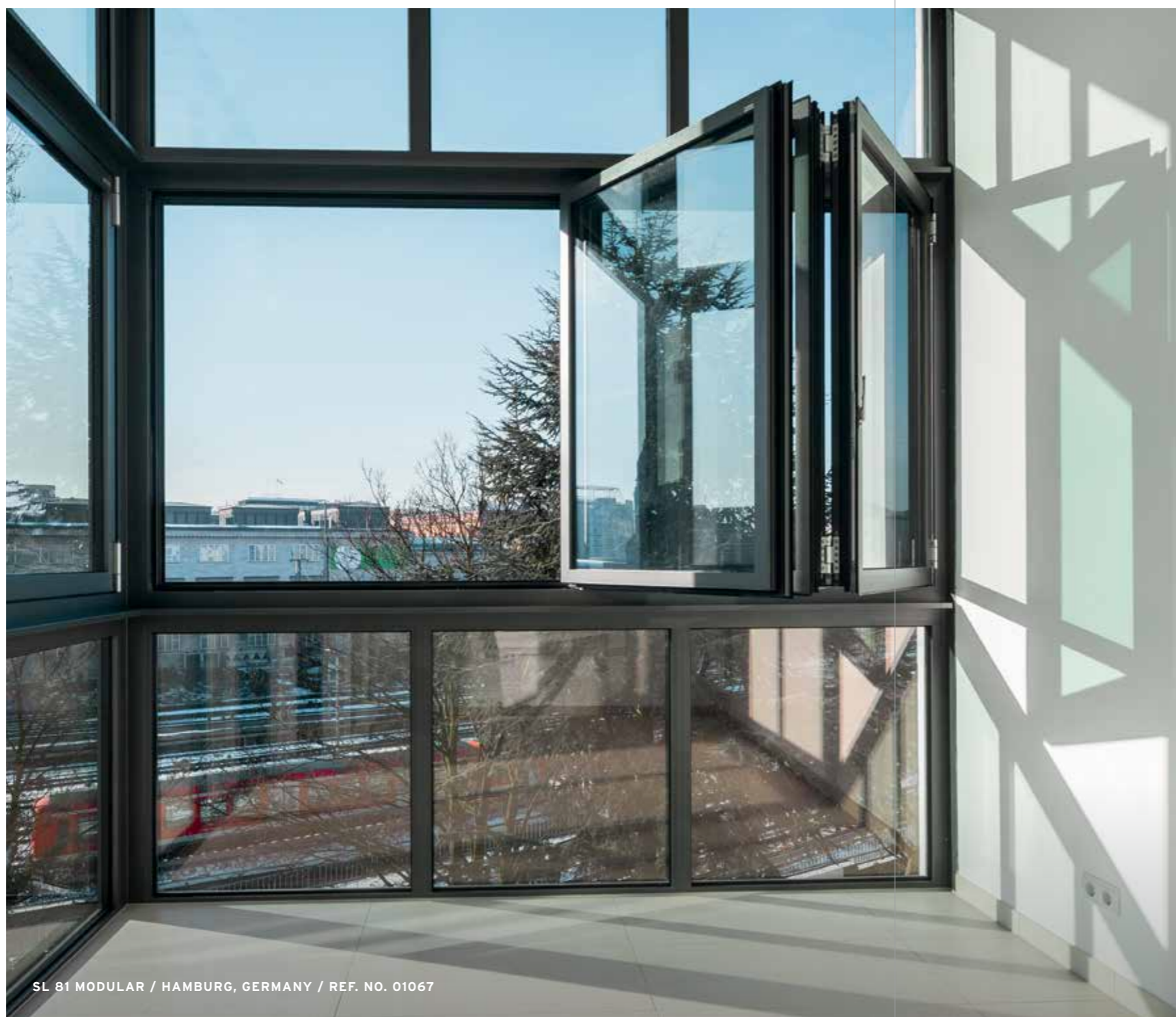





ECOLINE MODULAR / ZEEWOLDE, THE NETHERLANDS / REF. NO. 01590



**THE BI-FOLDING DOOR FAMILY VIDEO:**  
**ADVANTAGES, PRODUCTION AND**  
**TECHNICAL FEATURES**



SL 25 MODULAR / LÜBECK, GERMANY / REF. NO. 01435

*Non-insulated*  
**BALCONY  
AND FACADE  
SYSTEMS**

THE BALCONY AS A SHELTERED HAVEN  
TO REST AND RELAX

*Wind, weather and sound insulation: Glazing allows use of the balcony all year round*

Various all-glass systems offer wind, weather and sound insulation, and can be opened fully depending on the variant. Mounted on existing balustrades, as a transparent all-glass parapet or as floor-to-ceiling elements, they maintain the home's balcony aesthetic thanks to the option of full-surface opening. The system's incredible user-friendliness is also evident during cleaning, as even the outer panes can be cleaned from the inside without any problems. With its curtain wall design, the non-insulated version of the SL Modular not only improves a building's energy balance, it also permanently protects the building fabric from weathering.

**AT A GLANCE**

- Optimum protection from wind and weather
- Wide range of system variants provides an incredible number of options
- Various glazing options (TSG, TSG-H, LSG)
- Sound insulation up to 27 dB when installed
- Fast installation, easy to adjust even after installation
- The curtain-hung facade module can be used as a heat buffer and protects the building fabric



## SL 25

*All-glass, aluminium*

The SL 25 slide-and-turn system offers sound insulation in addition to repelling driving rain. The continuous glass surface allows an unrestricted view of the outside, so the balcony can still be used in bad weather. The system's sliding panels run along a track and can be pushed all the way to the left and/or right, and opened by turning them inwards or outwards.

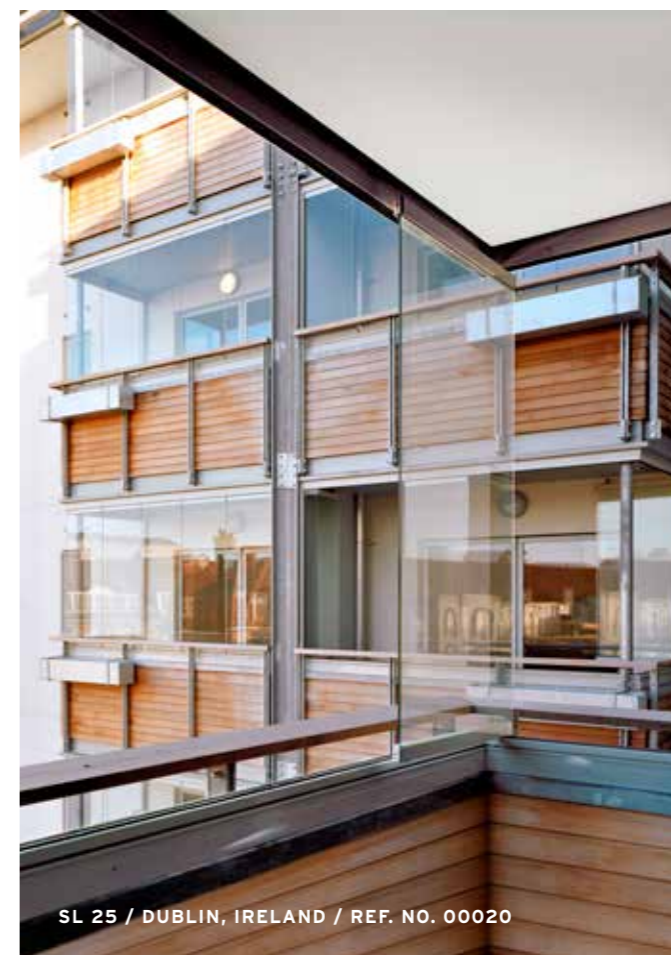

SL 25 / DUBLIN, IRELAND / REF. NO. 00020

### SL 25/SL 25R/SL 25 XXL - TECHNICAL DATA

- Precision ball bearings ensure panels are easy to move, even around corners
- Easy cleaning from the inside
- Height and width alignment possible after installation
- Panel vents provide permanent ventilation
- Resistant to driving rain
- Lockable, two-stage trickle ventilation on swing panel allows for controlled air flow
- Glass thicknesses of 6 and 8 mm; toughened safety glass (TSG)
- Also available in framed version - SL 25R
- SL 25 XXL for large panel sizes; glass thicknesses of 10 and 12 mm; toughened safety glass (TSG) or laminated safety glass (LSG)

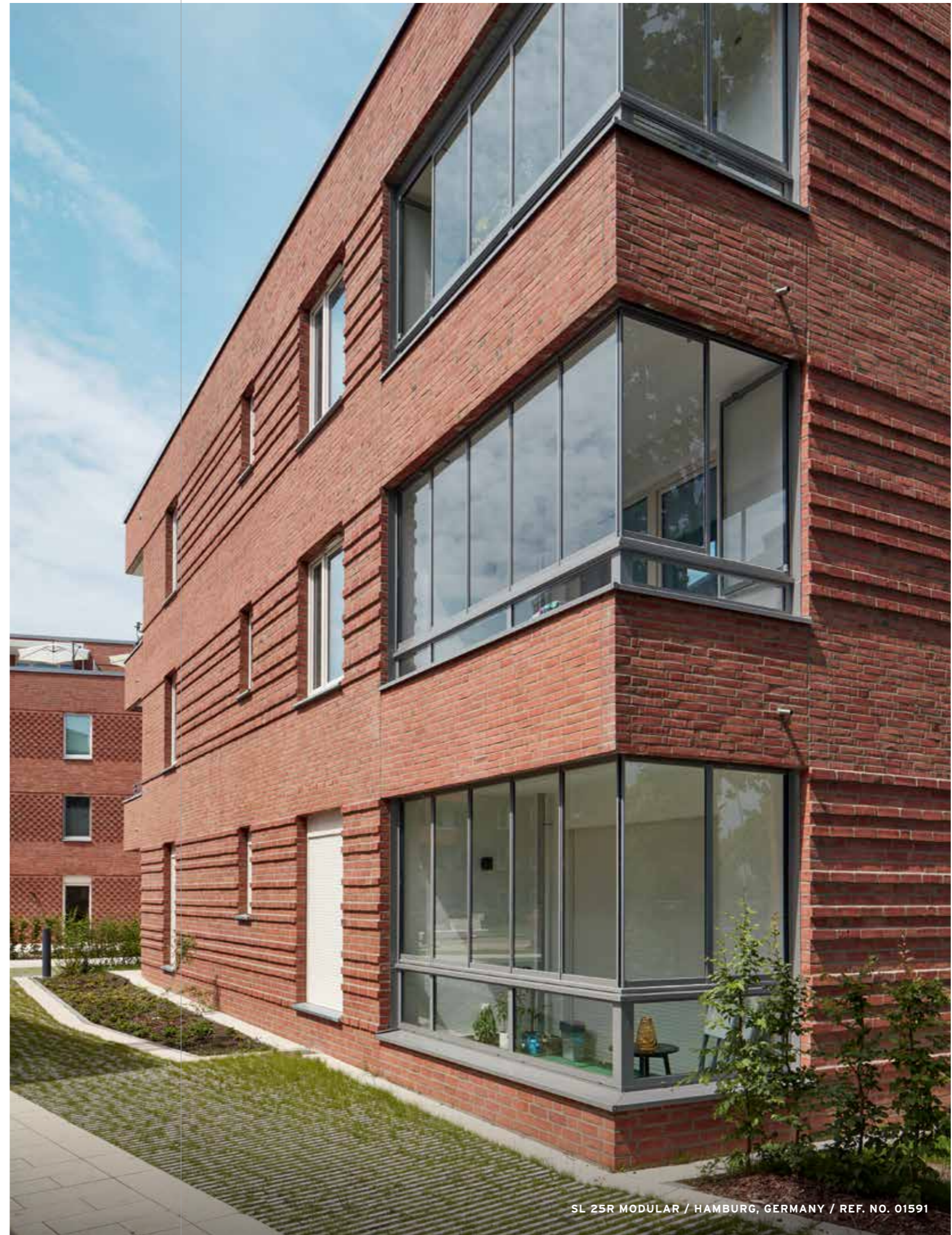

## SL 20e

*All-glass, aluminium*

This sliding system offers a combination of sound insulation and high transparency. Thanks to its intelligent driver function, its all-glass elements are extremely easy to operate. The individual panels are guided along two to five-track flat running tracks. In addition to this, the SL 20e sliding system can also be used as a fully transparent corner solution. The elements can be set up to slide to either the left or the right, as required. A framed version and, if necessary, a locking mechanism with different handle designs are available as optional extras.



### SL 20e - TECHNICAL DATA

- Easy to operate thanks to driver function for sliding the panel closed
- Glazing with toughened safety glass (TSG)
- Pane thickness of 8 or 10 mm
- 2, 3, 4 or 5-track version, depending on requirements
- Slides to and/or right as desired
- Framed panels and anti-lift protection available as optional extras





## SL 23

### *All-glass, aluminium*

Designing flush-mounted glass facades with flexible opening and closing options is a real challenge, particularly on higher floors. The SL 23 sliding system fulfils the necessary structural requirements, looks the part, and provides the required protection from noise, wind and weather. The system is mounted in front of the guardrail, and can be opened and closed easily despite the weight of the panels. The simplified self-opening system and the integrated soft-close lock also help with this. The built-in anti-lift device and guardrail also meet safety requirements for high floors.



#### SL 23 - TECHNICAL DATA

- Linear glass panes fixed in aluminium profiles at the top and bottom
- 2 and 3-track versions available
- Can handle 12 mm lowering and 5 mm raising
- Glass thicknesses: 12 and 15 mm toughened safety glass (TSG)/TSG-H with heat-soak test, or up to 16 mm laminated safety glass (LSG) with quadruple film
- Max. glazing: 17.5 mm
- Panes drilled and bolted in place at top and bottom anti-lift protection at top for maximum safety, even when subjected to high wind loads.

## SL MODULAR

### *Facade, non-insulated*

Like the insulated version, the non-insulated SL Modular also connects the balcony parapet with the glazing to form one unit. All the structural elements, from the surrounding frame to the balustrade, are prefabricated as a system combination at the factory. This allows the on-site installation of the modules and the glass elements to be completed quickly, without bothering the residents. Even elements up to a width of six meters are delivered as a unit and installed precisely using cranes to save time.

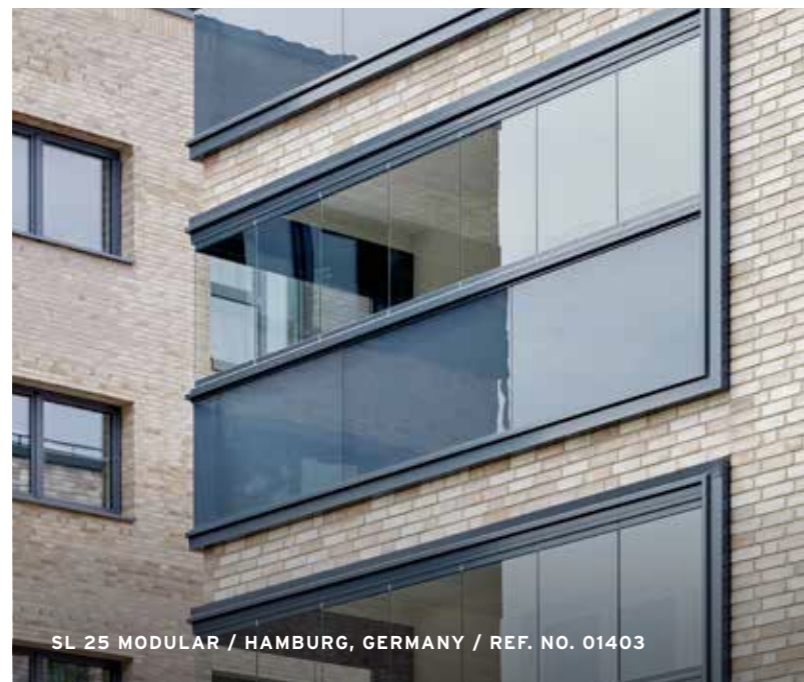

SL 25 MODULAR / HAMBURG, GERMANY / REF. NO. 01403

#### SL MODULAR NON-INSULATED - TECHNICAL DATA

- A visually appealing solution as a curtain-hung facade with integrated drainage
- Facade placed in front of the concrete slab, thus not reducing the balcony area
- No damage to the thermally insulated composite system
- Sound insulation up to 27 dB
- Individual parapet design
- Connection joints are clad inside and outside
- Protected concrete surfaces, no additional renovation costs
- Short construction times thanks to optimised prefabrication

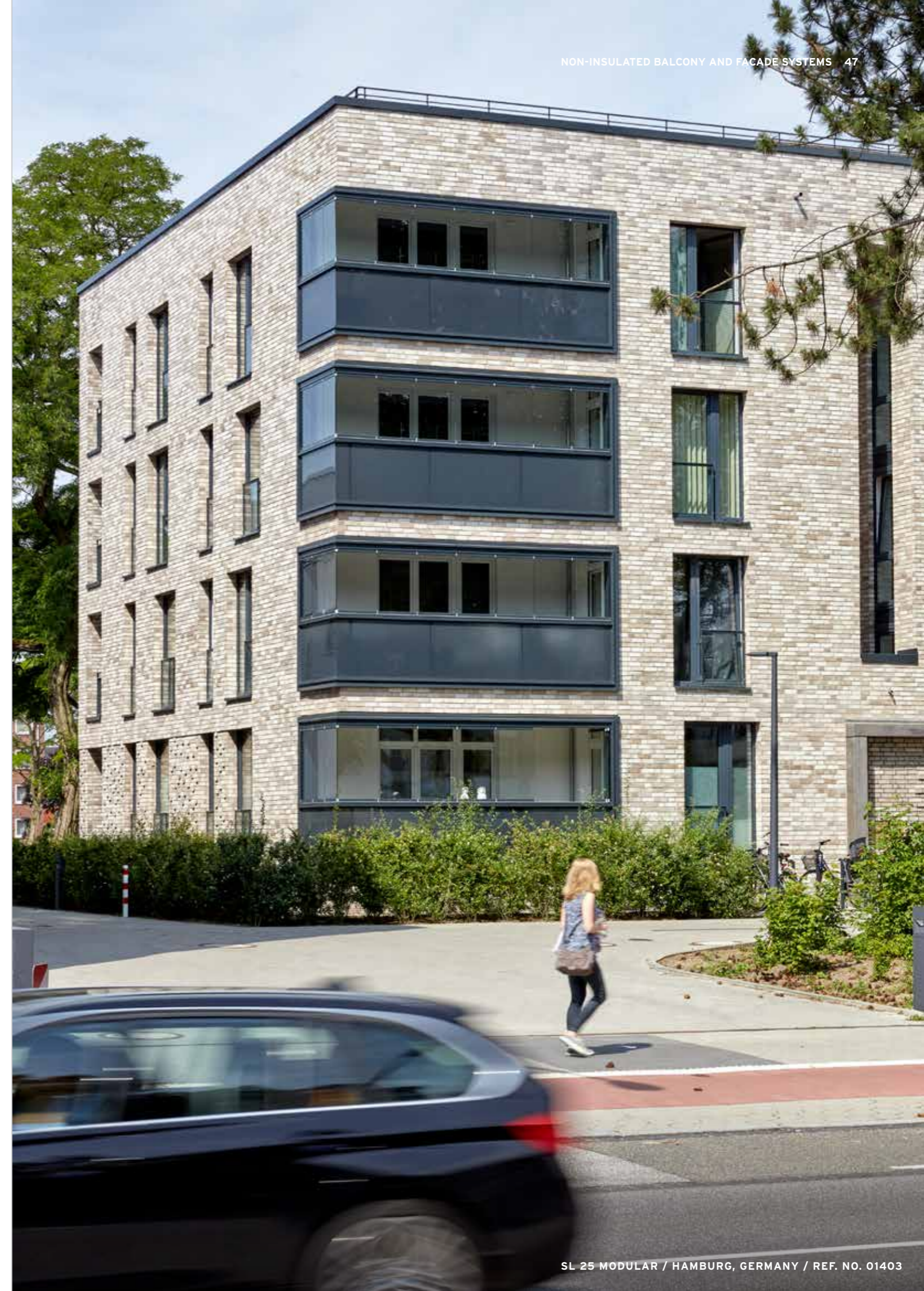



## SL PLUS

### *All-glass facade*

The SL Plus all-glass facade meets the requirements of modern, lightweight and - above all - completely transparent facade design. Glass balcony balustrades are safe and, always great to look at, low-wear and easy to clean. By combining the SL Plus with a Solarlux balcony glazing option, such as the SL 25, you can achieve a uniform and consistent facade appearance - without foregoing the advantages of a fully usable balcony that is protected from all types of weather.

#### SL PLUS - TECHNICAL DATA

- The balustrade can be fully clad with glass from the handrail to the underside
- The balustrade is not limited in length and can be extended as desired
- The perfect solution for a full-glass aesthetic in combination with Solarlux balcony glazing

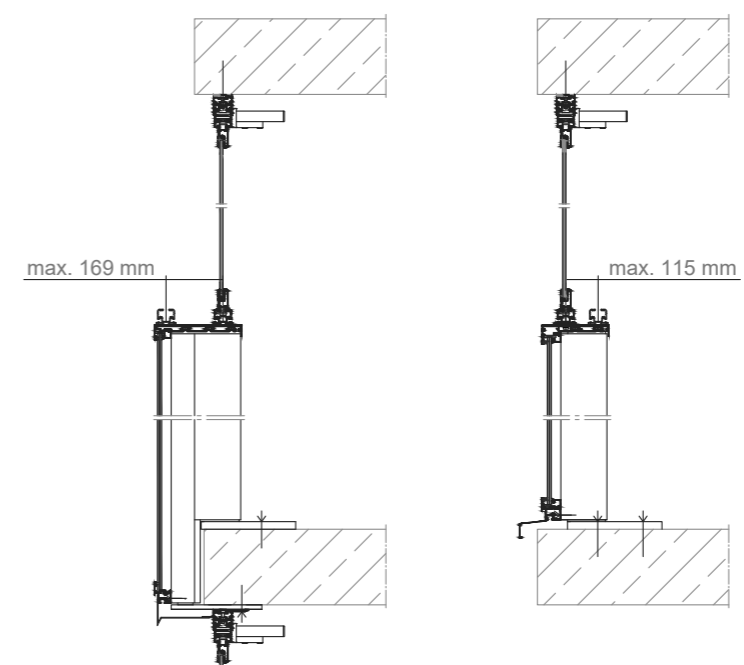

Curtain-hung variant

Mounted variant



SL 25 MODULAR / HAMBURG, GERMANY / REF. NO. 01267



YOU CAN READ THE REPORT  
ON THE SCHMUCKSHÖHE PROJECT  
IN HAMBURG ON OUR WEBSITE



*Sheltered*  
ACCESS  
BALCONIES  
WITH AUTOMATIC  
VENTILATION

GUARANTEED SMOKE-FREE  
ESCAPE ROUTES

## GLAZING SOLUTIONS FOR ACCESS BALCONIES

*Security for properties and their inhabitants*

Glazing permanently protects access balconies from bad weather, reducing the risk of accidents in rain, snow and icy conditions, in addition to providing sound insulation. SL access balcony glazing is guided along a multi-track rail and is perfectly suited to the requirements of multi-storey residential construction. The optional automatic ventilation in the event of smoke ensures that the glass panels are automatically opened using mechanical drive technology so that the escape routes remain smoke-free in case of a fire.



ACCESS BALCONY GLAZING / HAMBURG, GERMANY / REF. NO. 01593

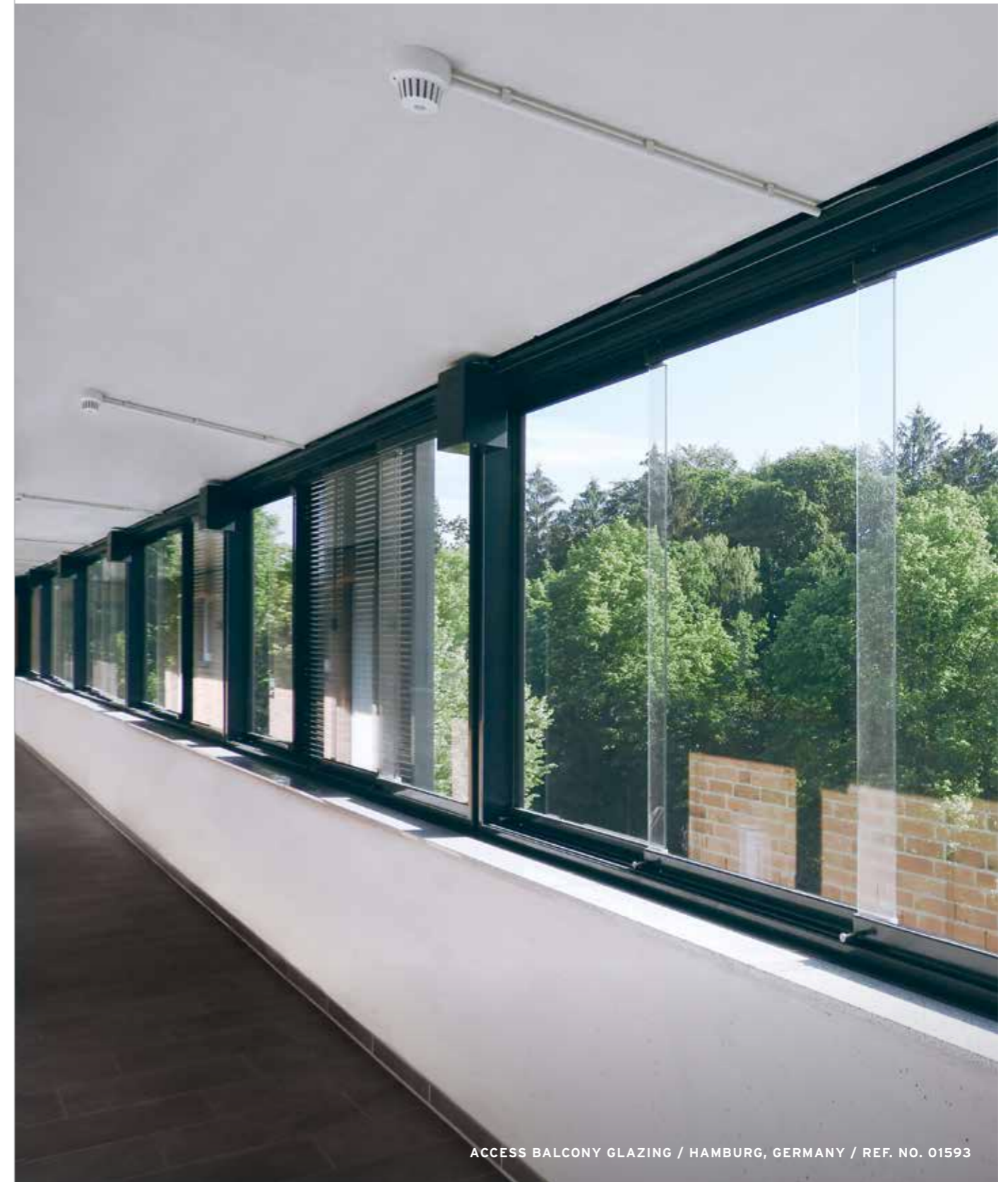

ACCESS BALCONY GLAZING / HAMBURG, GERMANY / REF. NO. 01593



ACCESS BALCONY GLAZING / HAMBURG, GERMANY / REF. NO. 00697



LEARN MORE ABOUT THE  
DESIGN FEATURES OF OUR  
ACCESS BALCONY GLAZING



CERO III / SCHWIELOWSEE, GERMANY / REF. NO. 01720

FOR SPACES  
WITH IMPRESSIVE  
*transparency*

CERO BY SOLARLUX

## SLIM FRAME, SPECIAL QUALITY

*Minimalist design for maximum transparency*

cero opens up rooms thanks to its large glass panels - its impressive transparency dissolves the boundary between the inside and the outside. Sight lines of just 34 mm provide a symmetrical and minimalist design. cero gives a room a special radiance and, with its narrow profile, provides a slender picture frame around your view. The high design standard of the system itself has already been confirmed by the awards it has won from numerous international juries. cero gives sophisticated building projects that extra-special touch.



CERO III / PRORA, GERMANY / REF. NO 01335



CERO III / PRORA, GERMANY / REF. NO 01335



**CERO IS EASY TO INTEGRATE  
INTO EXISTING ALARM SYSTEMS**



## CERO BY SOLARLUX

*Maximum comfort and maximum safety with 98% glass content*

Extremely large glass surfaces of up to 15 m<sup>2</sup> per panel place the system's quality and safety aspects in centre stage. cero has been tested and certified in accordance with the highest safety standards, and can be equipped with RC2 or RC3 anti-burglary glass as an optional extra. cero can be connected to alarm systems, lock monitoring systems, signalling systems such as broken glass sensors, and position monitoring systems. For maximum comfort, fully automatic operation of the sliding elements is possible including electromechanical locking and unlocking. Multiple panels can be moved interdependently using a control unit.



**CERO II - TECHNICAL DATA**

- Sliding element: 3 x 4 m, max. panel size: 12 m<sup>2</sup>
- Double glazing: 30 - 36 mm (TSG)
- Accessible running track in accordance with DIN 18040
- Max. panel weight: 600 kg
- Thermal insulation value (glass U<sub>g</sub> = 1.1 W/m<sup>2</sup>K)  
U<sub>w</sub> up to 1.35 W/m<sup>2</sup>K
- Impermeability to driving rain up to Class 9A
- Air permeability up to Class 4
- Wind resistance up to Class B4
- Insect protection up to a height of 3.50 m

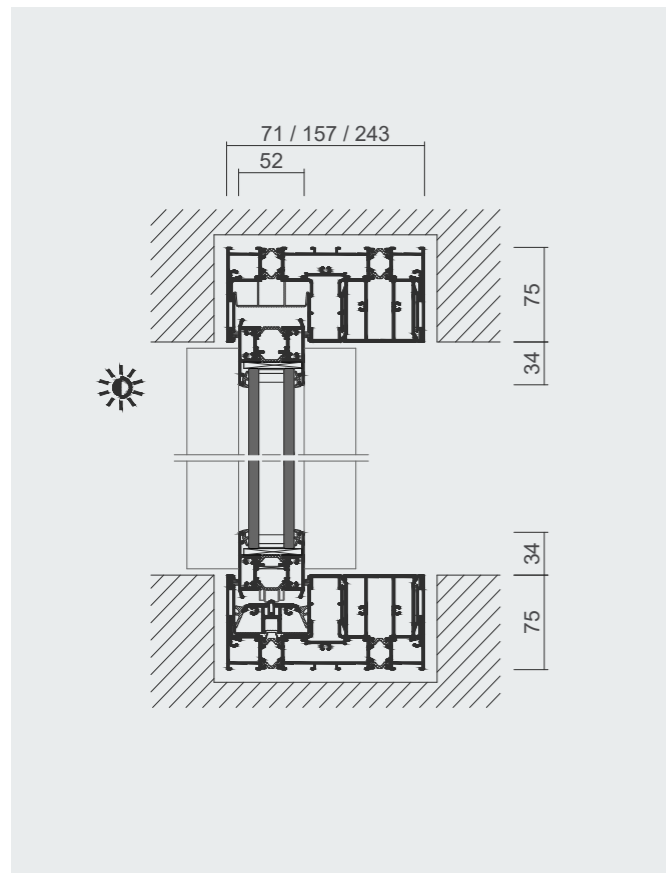

**CERO III - TECHNICAL DATA**

- Sliding element: 4 x 6 m, max. panel size: 15 m<sup>2</sup>
- Double glazing: 48 - 54 mm (TSG), 50 mm standard
- Accessible running track in accordance with DIN 18040
- Max. panel weight: 1,000 kg
- Thermal insulation value (glass U<sub>g</sub> = 0.5 W/m<sup>2</sup>K)  
U<sub>w</sub> up to 0.76 W/m<sup>2</sup>K
- Impermeability to driving rain up to Class E750
- Air permeability up to Class 4
- Wind resistance up to Class B4
- Insect protection up to a height of 3.50 m

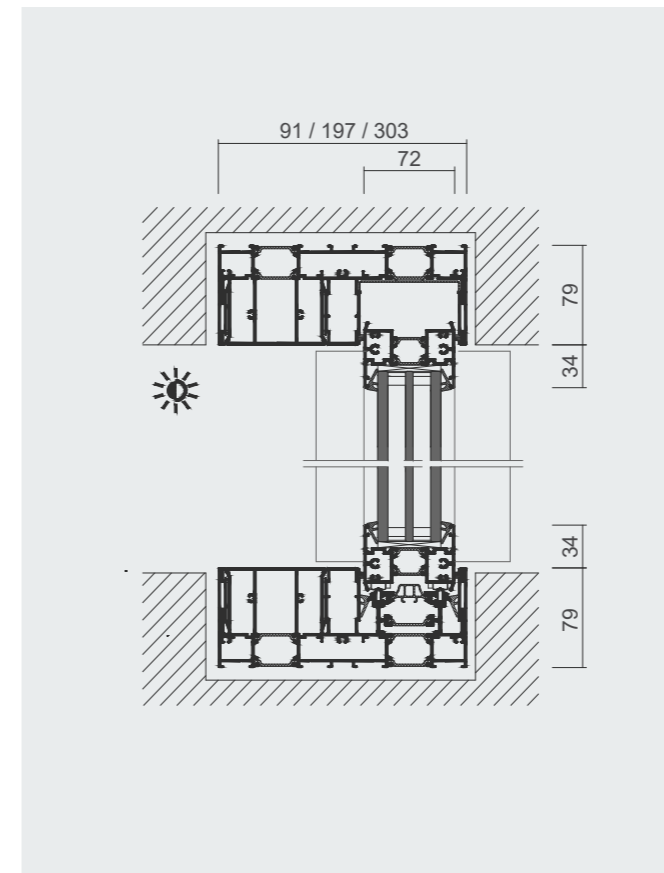



CERO III / OFFENBACH, GERMANY / REF. NO 01704



**PROJECT "LOFTHAUS MOLENPARK"**  
**IN OFFENBACH - DOCUMENTATION**  
**WITH VIDEO AND INTERVIEW**

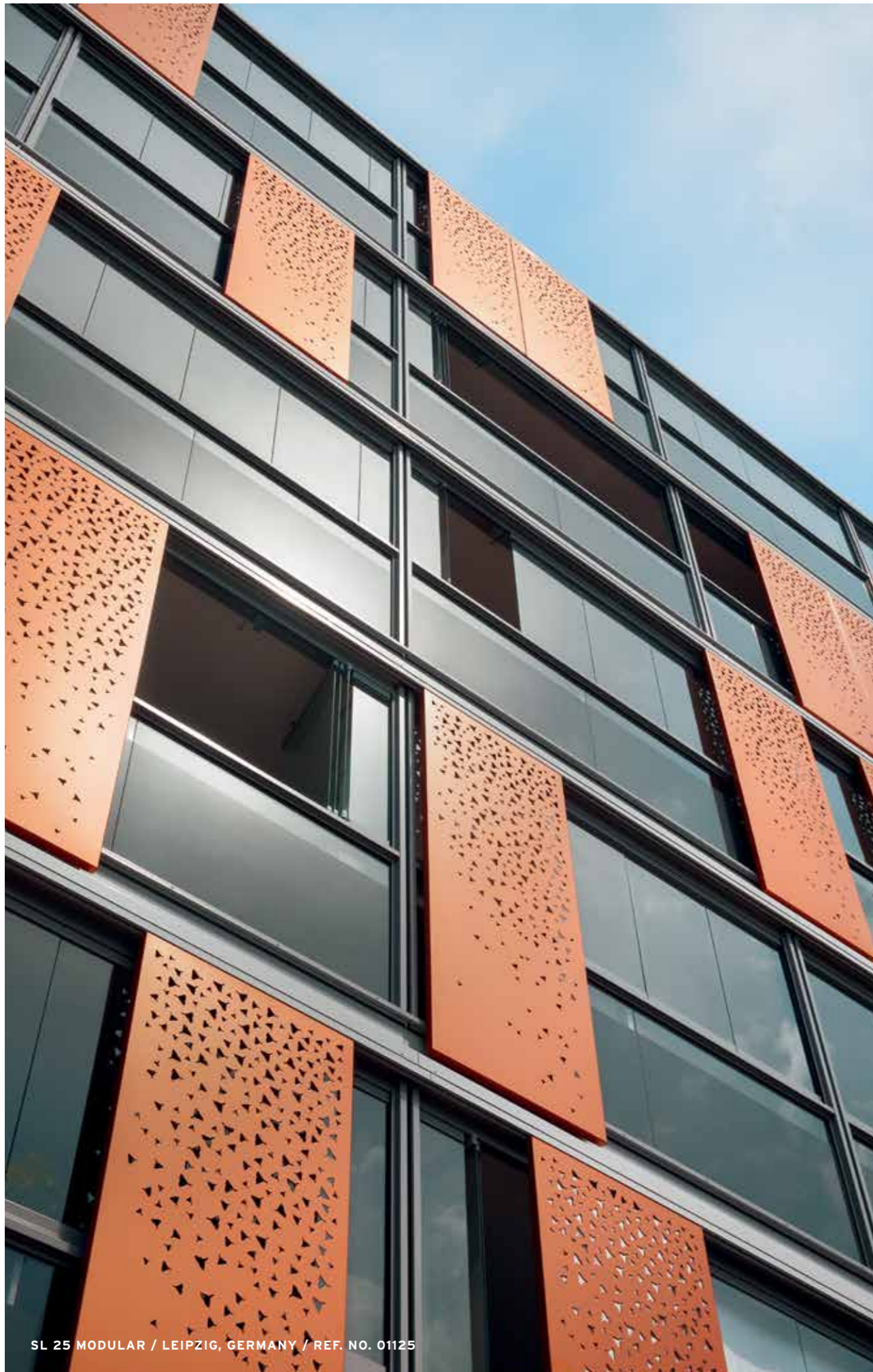

SL 25 MODULAR / LEIPZIG, GERMANY / REF. NO. 01125

# THE PERFECT *solution* FOR ANY REQUIREMENT

REFERENCE PROJECTS

REFERENCE 01417

# NEUSTADT CARRÉ, OSNABRÜCK

*New build*



## APARTMENTS WITH BI-FOLDING DOORS

Living in the city centre: The new residential quarter Neustadt Carré is home to 81 high-quality furnished apartments in the heart of Osnabrück, and was built on a former car park. Remarkably, the apartments have a glass front instead of a common balcony, which can be opened across the whole level.



**YEAR OF CONSTRUCTION**

2015

**CLIENT**

MBN Bau AG

**ARCHITECT**

PLAN.CONCEPT Architekten GmbH

**LOCATION**Kommenderiestrasse,  
Osnabrück city centre**TYPE OF CONSTRUCTION**

New build of a freehold apartment development consisting of four building complexes over an area of 4,470 m<sup>2</sup>: a total of 81 apartments measuring between 27 and 130 m<sup>2</sup>

**REQUIREMENTS**

New build in the course of inner-city densification; uninterrupted and stable facade that can be opened across its entire width

**SOLUTION**

- Flexible facade concept with bi-folding doors
- High outer cover provides plenty of light and protection from noise emissions even when the glazing is closed; the living space behind it opens to the loggia
- 30 bi-folding doors, a total of 122 bi-folding door panels
- Optimum ventilation thanks to fans installed vertically in the lateral fixed elements for a needs-based fresh air supply via pressure difference; no power supply required

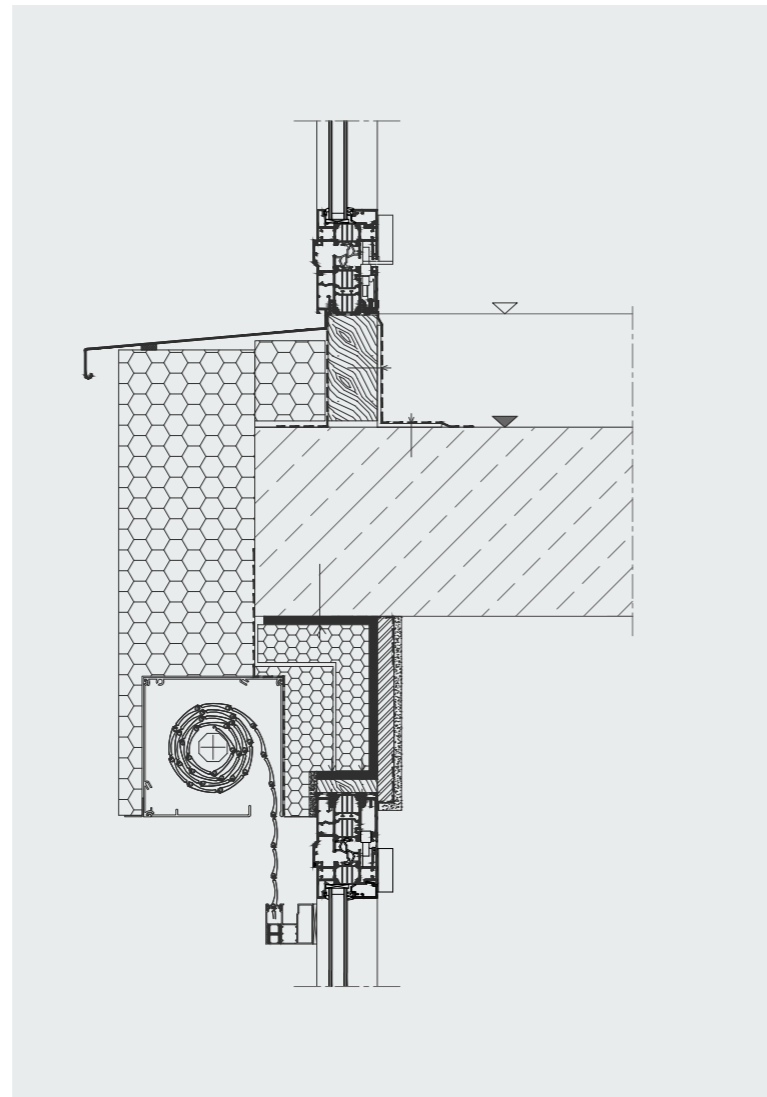

REFERENCE 01306

# HIGH-RISE RESIDENTIAL BUILDING, POPPENRADE, KIEL

*Energetic renovation*



## THERMALLY INSULATED SL MODULAR AND BI-FOLDING DOORS

The high-rise residential building, Poppenrdae 5, in Kiel's Poppenrade residential district, shapes the area on the city's eastern shore. Built in the 1970s, the 202-apartment settlement was initially considered a highly popular neighbourhood. Its outdated energy standards and the consequent threat of apartment vacancy prompted the housing cooperative, Wohnungsbau-Genossenschaft Kiel-Ost eG, to undertake extensive energy renovation and modernisation measures.

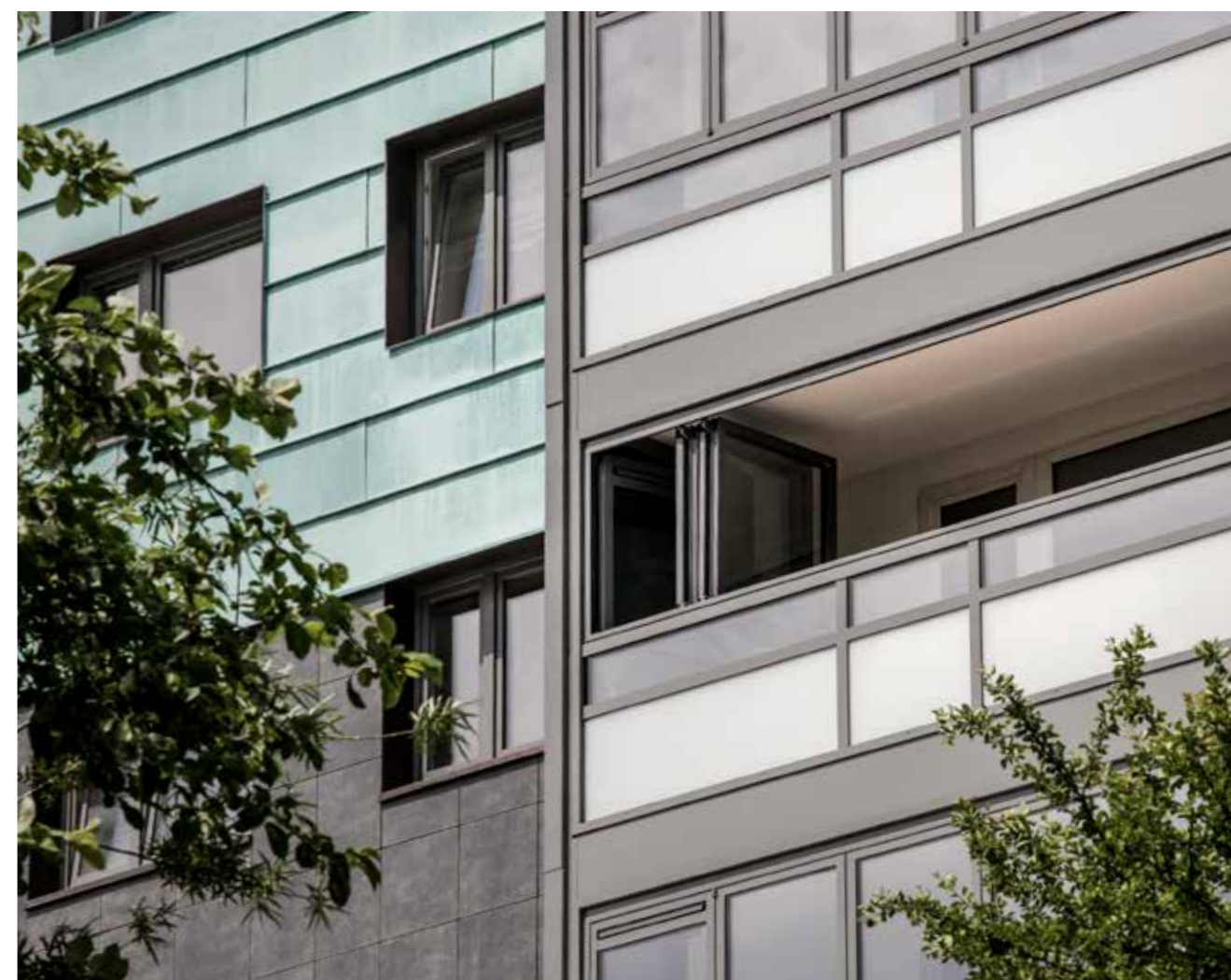

**YEAR OF CONSTRUCTION**

2013 - 2016

**CLIENT**

Wohnungsbau-Genossenschaft  
Kiel-Ost eG

**ARCHITECT**

AX5 Architekten

**LOCATION**

Poppenrade 5, Kiel Ellerbek

**TYPE OF CONSTRUCTION**

Energy renovation of the balconies  
and external facade of the fifteen-  
storey residential building

**REQUIREMENTS**

Lasting energy renovation of the  
facade as well as overcoming the ex-  
isting thermal bridges of the balcony  
slab that project into the living space;  
optimised ventilation concept

**SOLUTION**

- Balconies renovated to create full living space while retaining open-air aesthetic
- Cladding of the facade with high-quality copper in combination with the thermally insulated balcony module SL Modular and the SL 60e bi-folding door
- 56 units of SL Modular with a total of 280 panels of thermally insulated bi-folding doors; the 56 systems are equipped with an 80-cm-wide fan for optimum air circulation

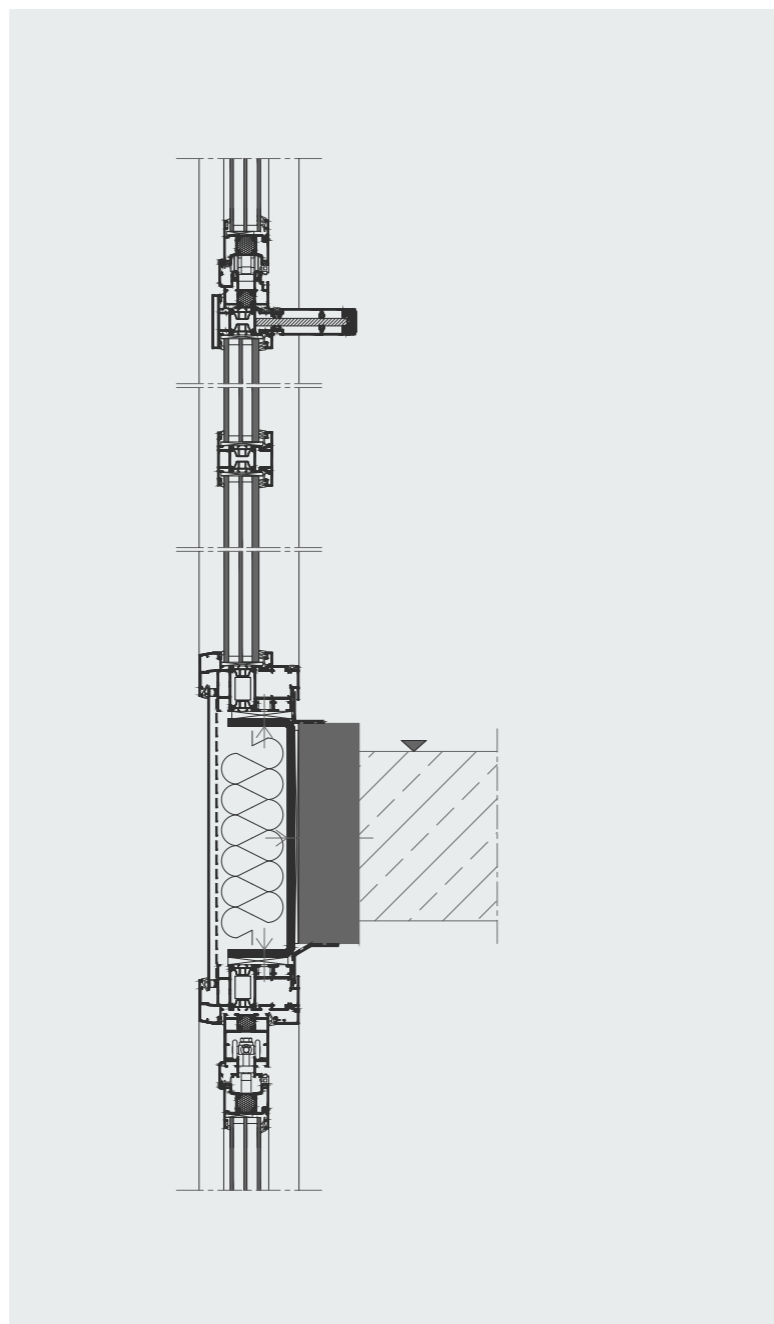

REFERENCE 01120

# RESIDENTIAL COMPLEX, HATTINGEN

*Complete renovation*



## **ALMOST A NEW BUILD - WITH BI-FOLDING DOORS ON A BALCONY PARAPET**

This four-storey residential complex in the Hattingen's Holthausen district dates back to 1977 and comprises 77 apartments. The building was in a very poor structural condition, in particular due to insufficient thermal insulation. The aim of the renovation was to bring the building up to the standard of a new build in terms of its energy and aesthetic features, and to make it competitive again on the housing market.





**YEAR OF CONSTRUCTION**

2013

**CLIENT**

Gartenstadt Hüttenau eG

**ARCHITECT**

Architekturbüro Degener

**LOCATION**

Hattingen, Holthausen

**TYPE OF CONSTRUCTION**

Energy renovation of the balconies and external facade of the four-storey residential complex

**REQUIREMENTS**

Lasting energy renovation of the facade to new-build standards; the challenge was to design the bi-folding door for three structurally different balcony types in order to achieve a uniform facade appearance

**SOLUTION**

- Use of the bi-folding door with triple insulating glazing and improved edge bond as a “warm-edge spacer” mounted on a balustrade insulated on site in order to ensure that the balcony aesthetic is retained when opening the folding door
- A self-adjusting trickle ventilation unit integrated into the upper profile ensures a consistently pleasant indoor climate
- The enclosure of the balconies prevents thermal bridges; bringing the thermal level forward saves the costs of conventional renovation measures
- This measure fulfils the high requirements of the Energy Saving Ordinance (EnEV)

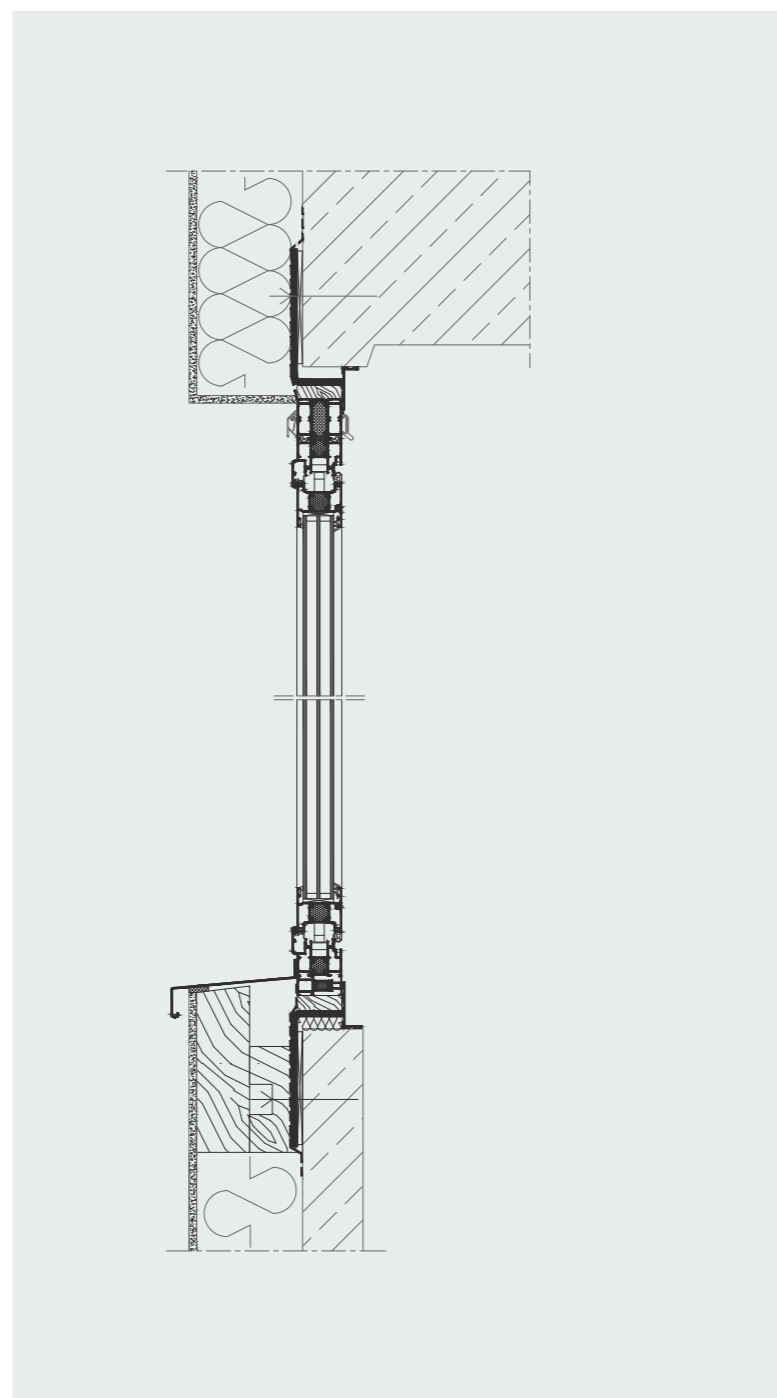

BEFORE



AFTER

REFERENCE 01188

# AN DER VERBINDUNGSBAHN, HAMBURG

*Sound insulation*



**RESIDENTIAL COMPLEX WITH SL PLUS AND SL 25**  
"Verbindungsbahn" refers to the railway junction line in Hamburg. The brownfield land directly adjacent to the railway line was long considered unsuitable for residential development due to the high noise levels. This conflict was resolved in 2017 with a new building and the right noise protection concept.



**YEAR OF CONSTRUCTION**  
2017

**CLIENT**  
GS-Bau GmbH, Neu Wulmstorf

**ARCHITECT**  
LRW Architekten und Stadtplaner

**LOCATION**  
Hamburg, Rotherbaum  
"An der Verbindungsbahn"

**TYPE OF CONSTRUCTION**  
Townhouse with separate entrance,  
small maisonettes and multi-storey  
apartments, panoramic suite

**REQUIREMENTS**  
Facade with a high level of sound  
insulation and maximum transparency

**SOLUTION**  
Double-skin facade made of virtually  
frameless glass elements in combi-  
nation with prefabricated, filigree  
steel-concrete facade parts; 27 units  
of double facade equipped with 360  
SL 25 slide-and-turn elements

**TESTED AIRBORNE SOUND  
INSULATION**  
22 dB

Awarded the  
"WohnbauPreis Hamburg 2017"

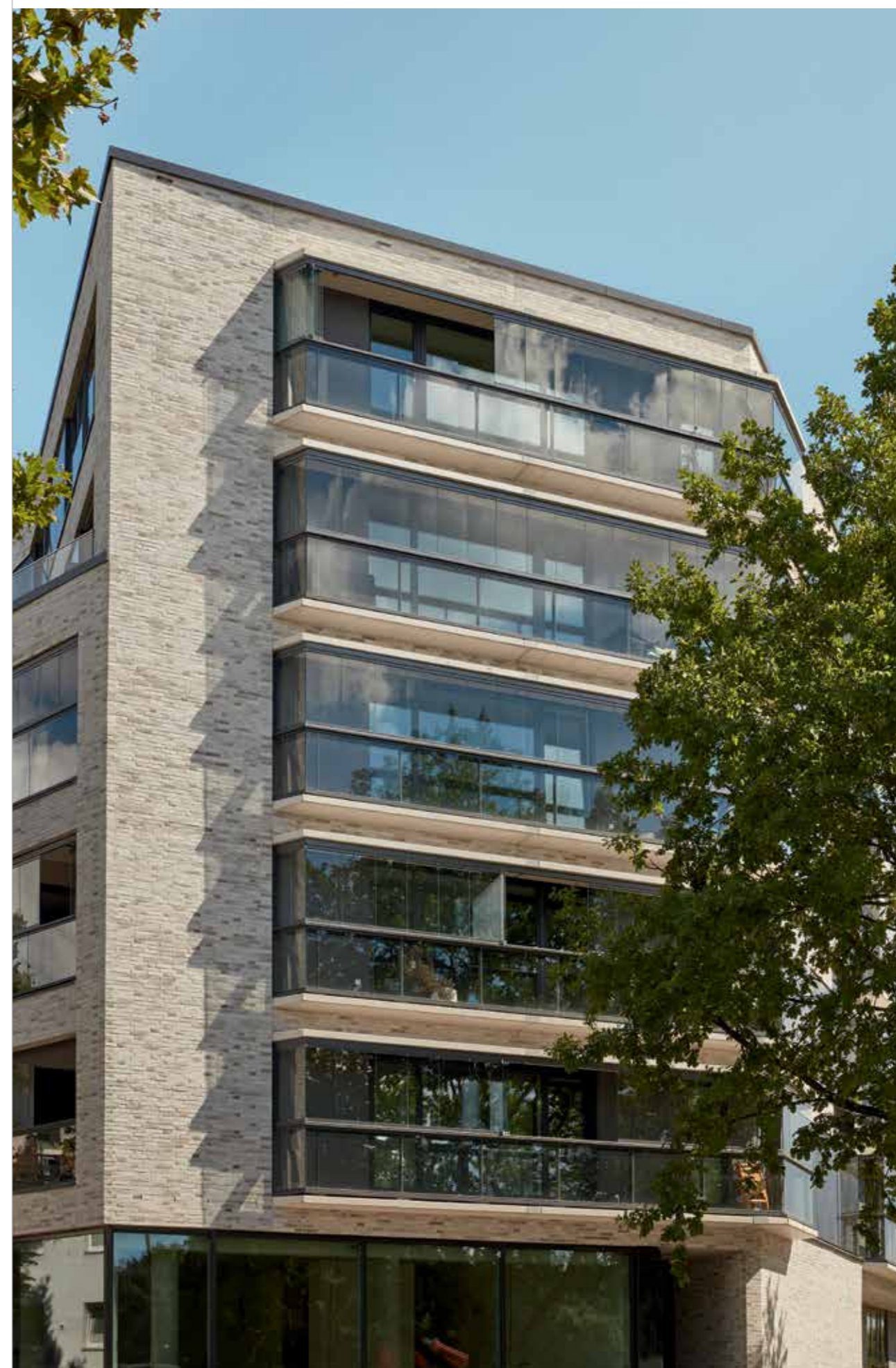
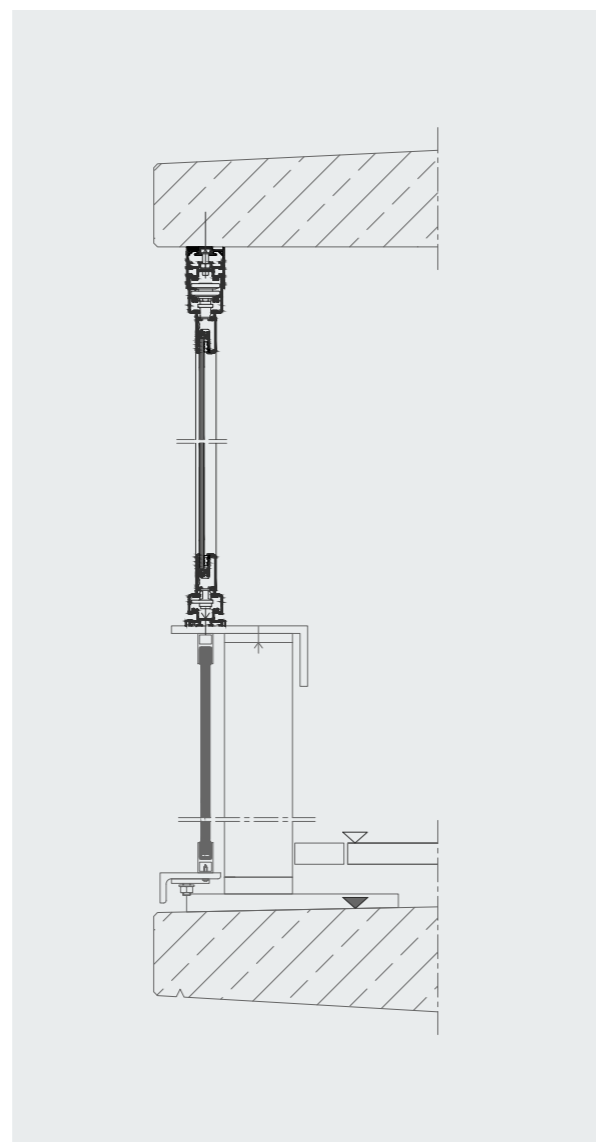

REFERENCE 01567

# SKYLINE LIVING, STUTT GART

*New build*



## WIND AND WEATHER PROTECTION AT THE HIGHEST HEIGHTS

With around 22 floors and a height of 75 metres, the "Skyline Living" residential tower in Stuttgart poses special requirements for the facade - and especially for the glazed balconies. Ensuring that the structural requirements brought about by the high wind loads were met and that the balconies could be used at all times, even on the upper floors, was essential. An SL 25 slide-and-turn system on a transparent balustrade ticked all these boxes.



**YEAR OF CONSTRUCTION**

2016/2017

**CLIENT**

Bülow AG, Stuttgart

**ARCHITECT**

StructureLab (concept architecture)

**LOCATION**

Stresemann Strasse, Stuttgart

**TYPE OF CONSTRUCTION**

Combination of modern office spaces and living solutions with approx. 145 apartments on 21 floors

**REQUIREMENTS**

Unrestricted balcony usability, even on the upper floors, with transparent weather and sound insulation

**SOLUTION**

The frameless SL 25 slide-and-turn system was mounted on the glass balustrade. The panes can be moved to the side one at a time and turned open to form a bundle that locks in place at a right angle and remains secure even in heavy winds. Although it is not thermally insulated, thanks to the depth of the balcony, the glazing acts as a heat barrier so that pre-heated fresh air can be let into the indoor living space on cooler days.

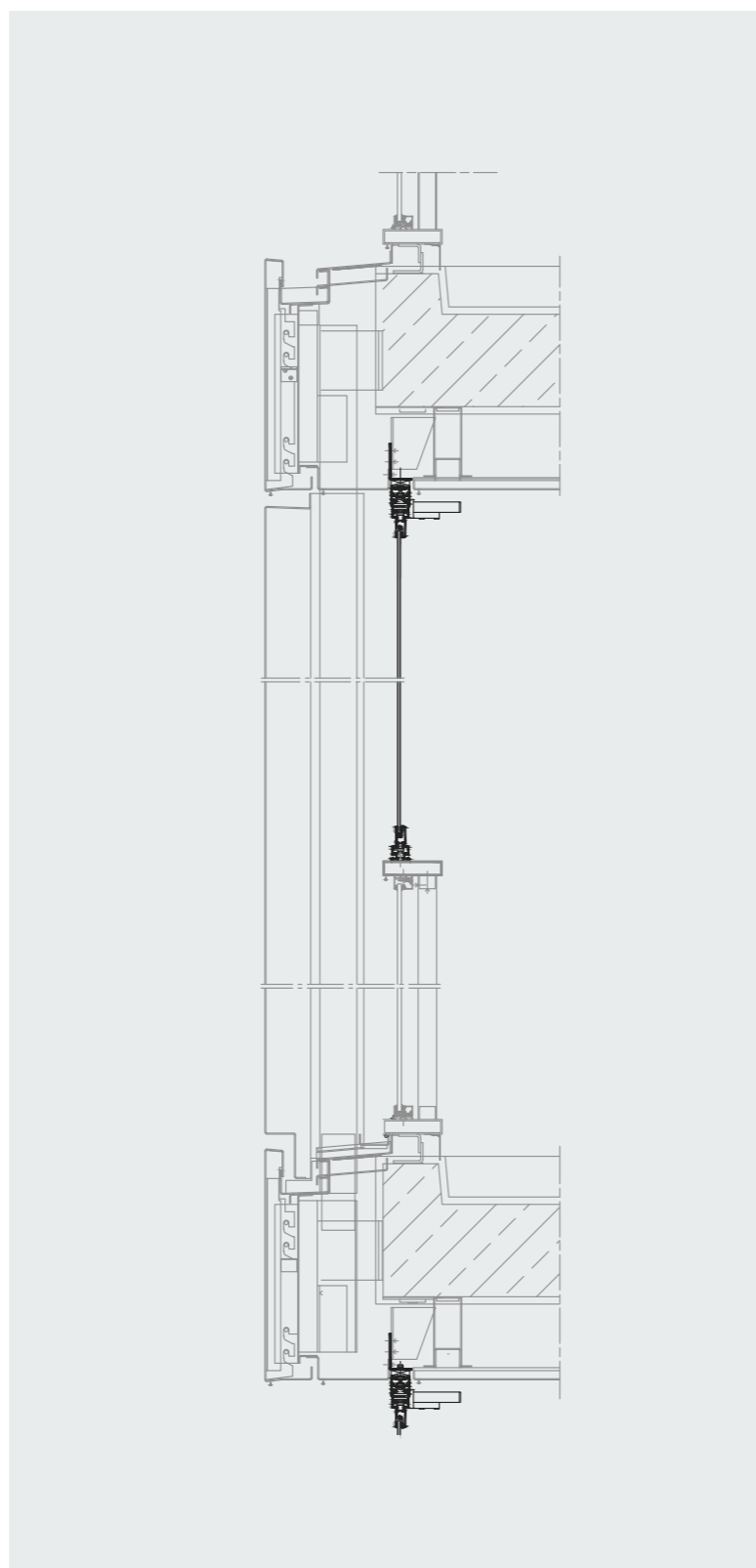

REFERENCE 01579

# THE GARDEN, BERLIN

*New build*



## **SOUND INSULATION WITH SL 25**

In Berlin Mitte, the residential district "The Garden", which contains freehold and rented apartments, was built directly opposite the new Federal Intelligence Service headquarters. It is a quiet, green living oasis in the middle of the vibrant city. As soon as you enter the gate on Chausseestrasse, the hustle and bustle of the city is left behind. The challenge: The residential units facing the street, which were to be used as rental apartments, had to be protected against the noise level of the busy thoroughfare connecting Wedding and the city centre.



**YEAR OF CONSTRUCTION**

2016

**CLIENT**

Garden Projektentwicklung GmbH

**ARCHITECT**

Eicke Becker Architekten

**LOCATION**

Chausseestr. 57-60, Berlin Mitte

**TYPE OF CONSTRUCTION**

Seven-storey stacked construction of a total of 17 houses with various projections and recesses in the facade and the balconies; unit sizes of 2-bedroom apartments over townhouses, upscale housing to rent and buy

**REQUIREMENTS**

Sound insulation for the rented apartments on Chausseestrasse

**SOLUTION**

64 SL 25 slide-and-turn systems with a total of 337 panels were installed on an existing transparent balustrade, thus protecting the residential units behind them from noise

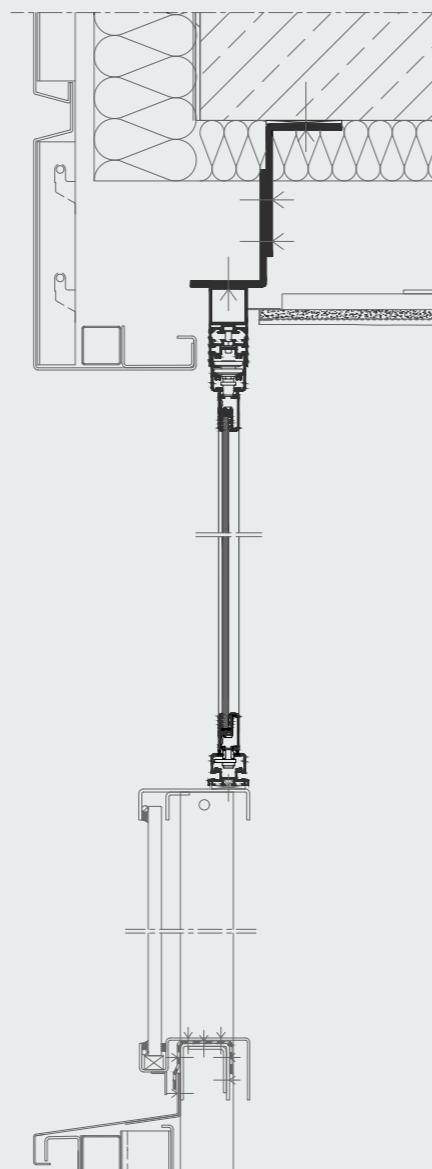

REFERENCE 01418

# TASSILOPLATZ, MUNICH

*New build*

## SOUNDPROOFING WITH SL 25 XXL

In the summer of 2017, a square was closed on the former Bernbacher premises in Munich. The new Tassilo construction project, completed by Baywobau Immobilien AG, harmoniously complemented the existing houses in the immediate vicinity.





**YEAR OF CONSTRUCTION**  
2017

**CLIENT**  
Baywobau Baubetreuung GmbH

**ARCHITECT**  
prpm Perret Maluche Stuke Architekten  
& Stadtplaner GmbH

**LOCATION**  
Haidhausen, Munich

**TYPE OF CONSTRUCTION**  
New building "Tassilo" with 225 free-  
hold apartments with selected facilities

**REQUIREMENTS**  
Balconies must be equipped with  
sound insulation due to the railway  
tracks adjoining in the south and the  
main road in the west

- SOLUTION**
- 274 balconies are equipped with al-  
most 1,700 SL 25 XXL glass elements
  - The SL 25 XXL slide-and-turn system  
acoustically shields both balconies and  
ground-floor terraces
  - Sound insulation of over 11 dB
  - The balcony aesthetic is retained  
thanks to the full-opening option
  - Protection of the facade against wind  
and rain; weathering is effectively  
prevented
  - The glazing creates an insulating  
cover as a buffer zone between  
the indoor climate and the outside  
temperature
  - Constant fresh air circulation and a  
healthy balcony climate thanks to  
narrow cracks between the elements

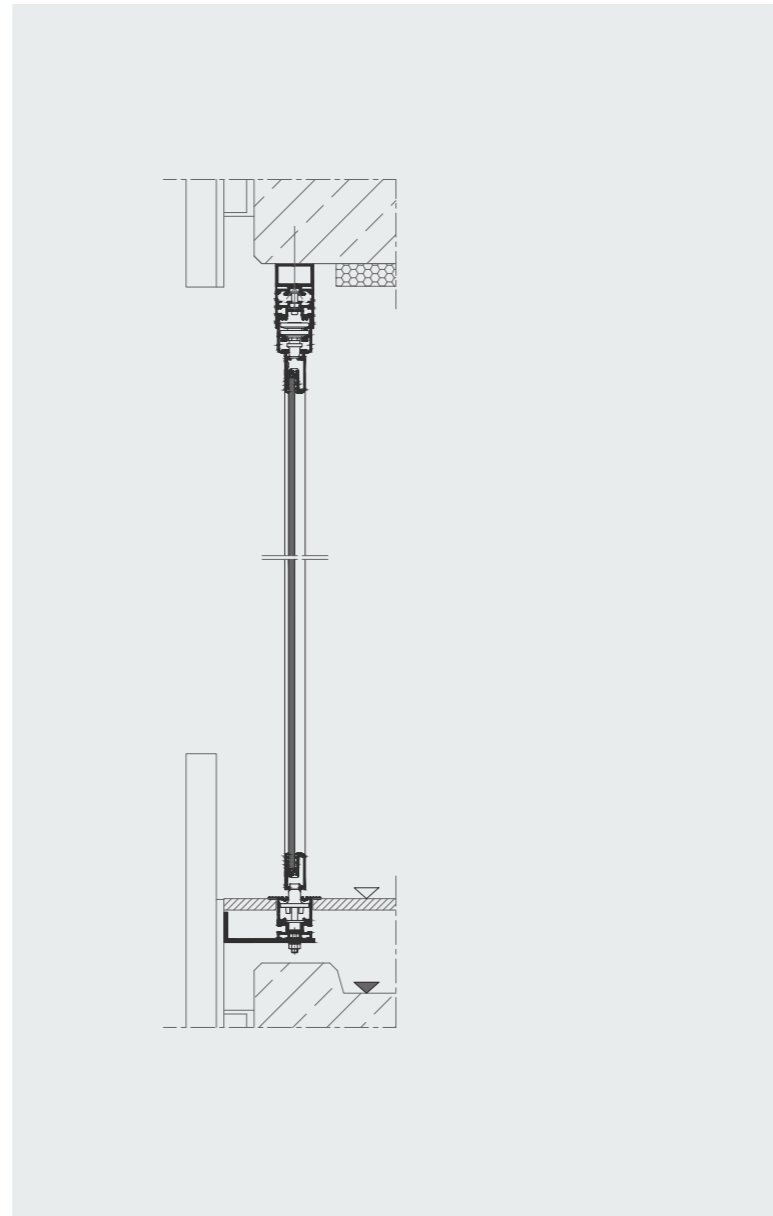

REFERENCE 01586

# HOTEL SAND, TIMMENDORFER STRAND

*New build*

## HIGH-QUALITY EXTENSION WITH A STYLISH AMBIENCE

The SAND hotel is located in the popular holiday resort of Timmendorfer Strand, very close to the beach. The renowned hotel was opened in 1930 and has since been gradually renovated and extended. The new extension will stylishly expand the capacity of the spa hotel. The slim 34-mm profiles of the cero sliding windows frame the view of the Baltic Sea like a picture frame.

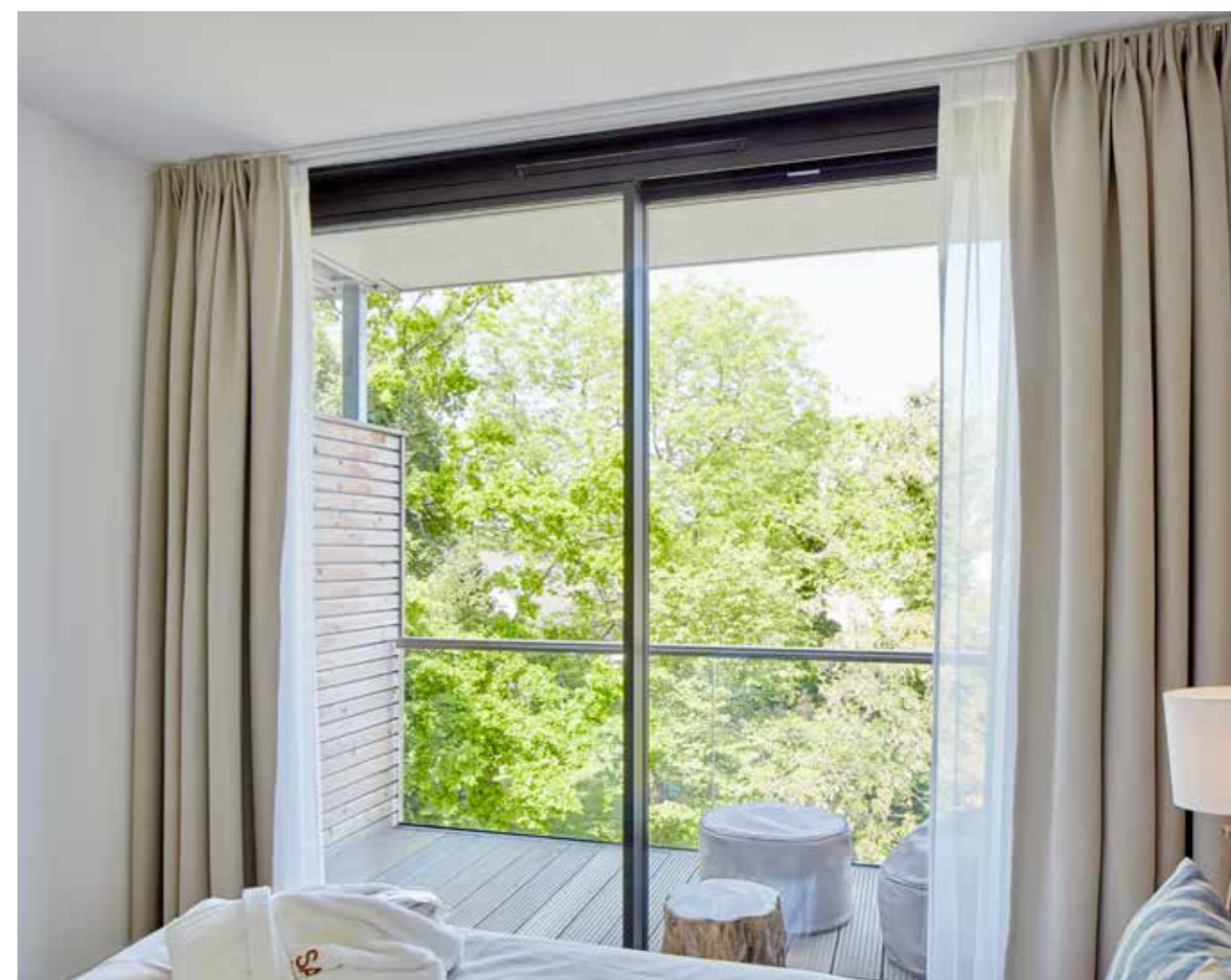

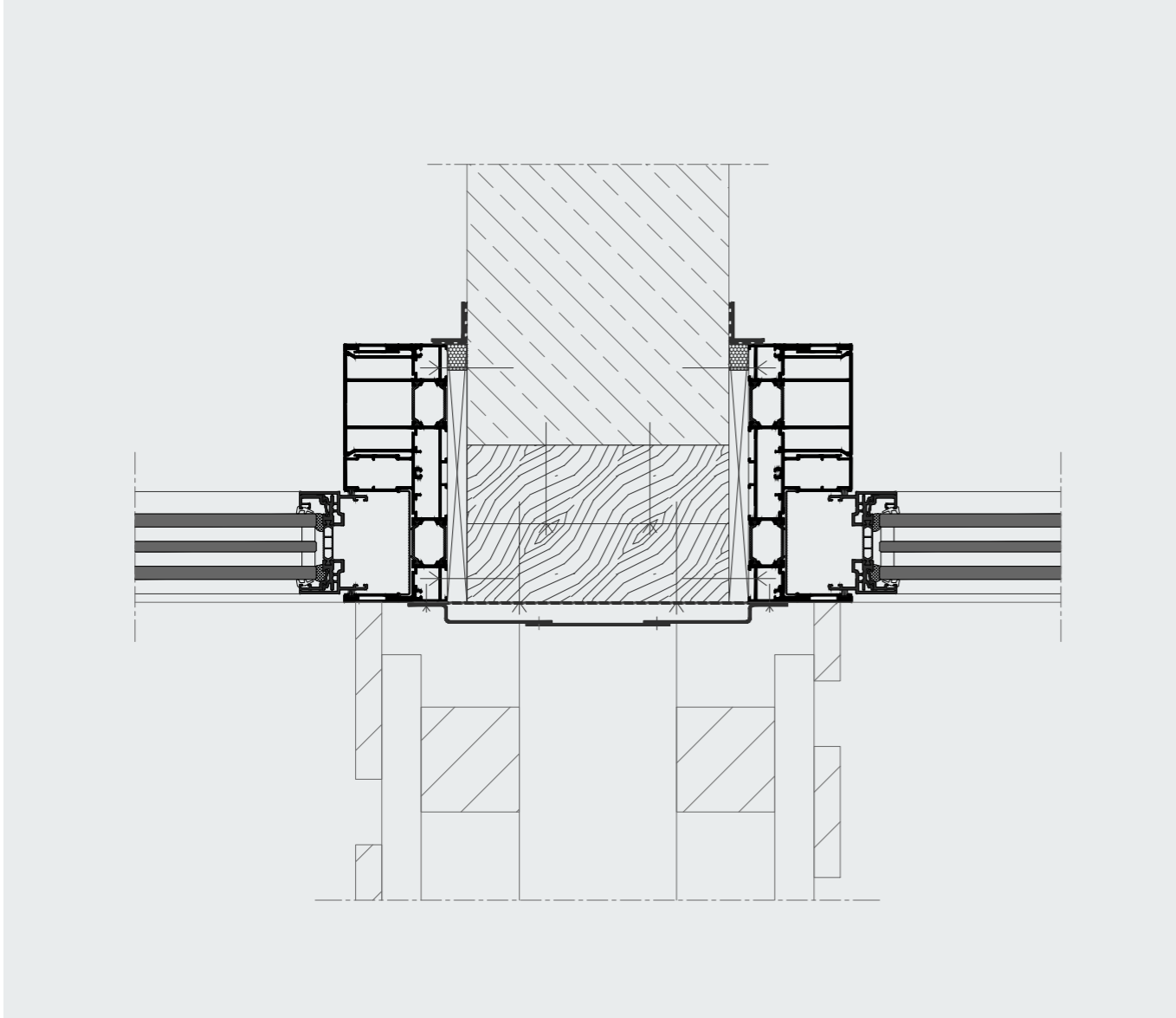

**YEAR OF CONSTRUCTION**  
2017

**CLIENT**  
Marion und Lambertus Muller

**ARCHITECT**  
Planungsbüro Falk,  
Architekt Roald Pall

**LOCATION**  
Timmendorfer Strand

**TYPE OF CONSTRUCTION**  
New build as an extension of the  
existing hotel complex

**REQUIREMENTS**

Stylish extension of the capacity of  
the spa area with large windows for  
maximum light in the rooms

**SOLUTION**

- 34 cero III systems with two  
elements each
- One fixed element, one sliding  
element

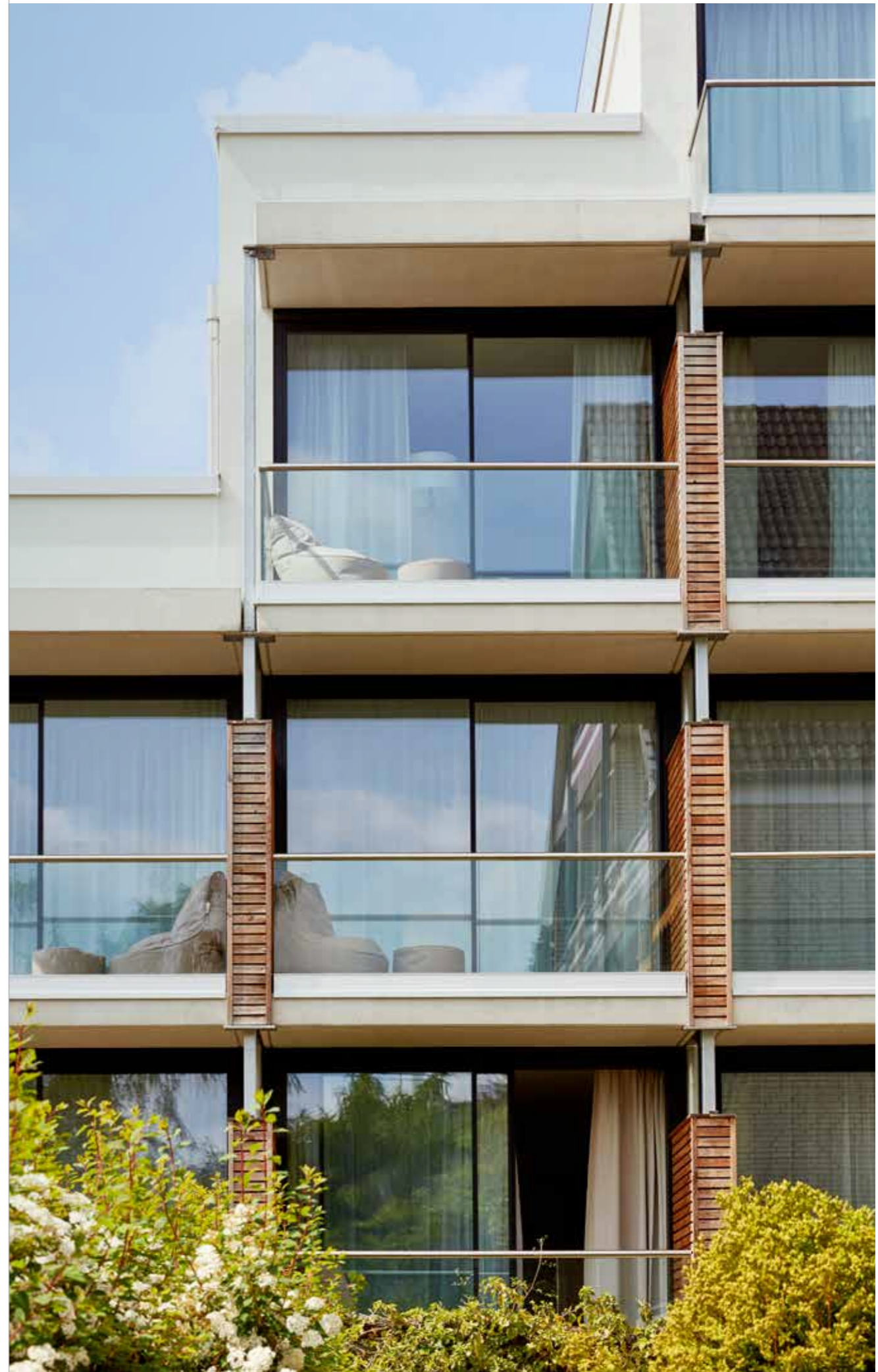



PLACE YOUR  
PROJECT  
IN *good hands*

EVERYTHING FROM A SINGLE SOURCE

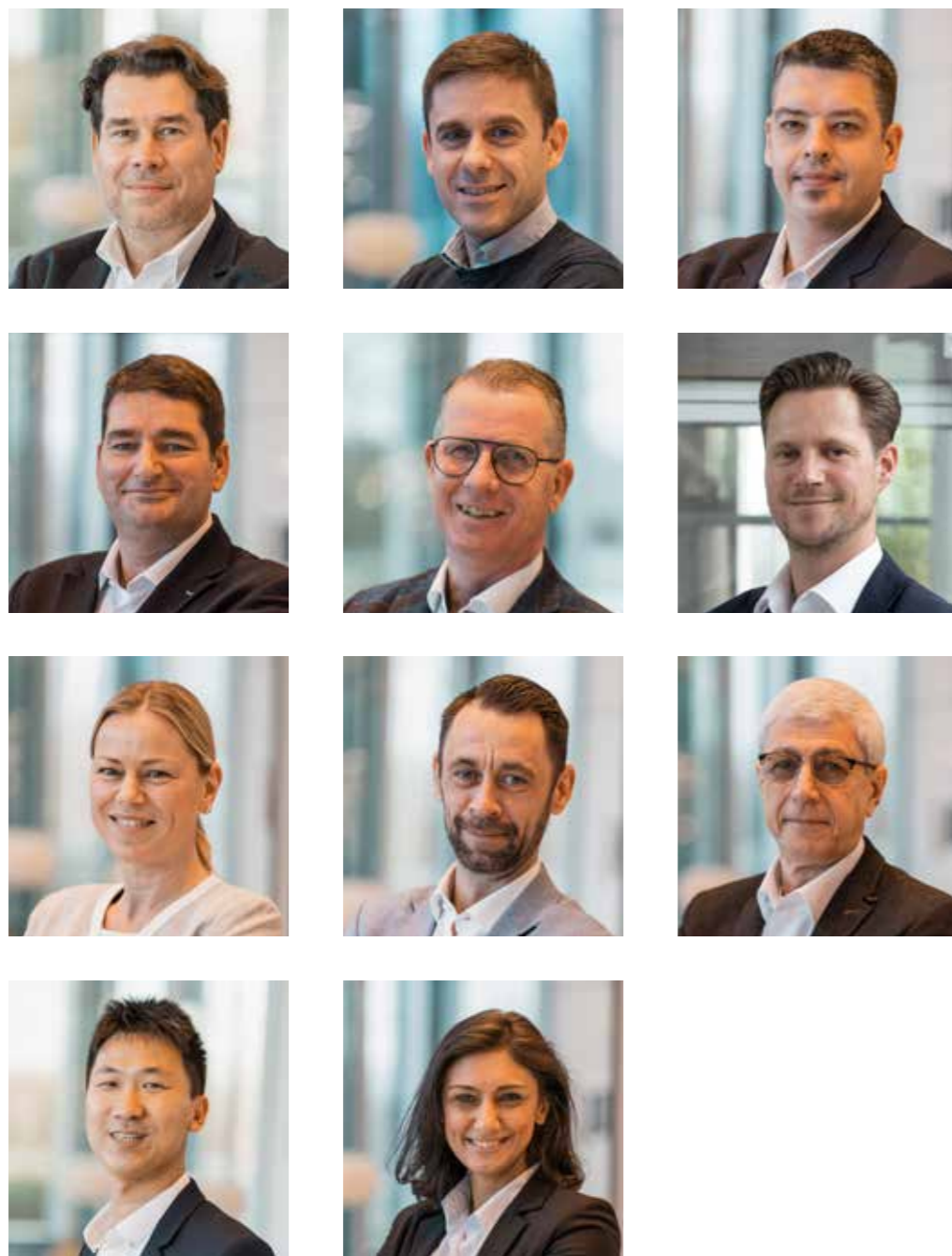

Our team of experienced property estimators, architectural consultants, planners and engineers will help you in the execution of your project - regardless of whether it is a new build project or an energy renovation.



## ALL-ROUND SERVICE

*We will help you through every stage of your project, from start to finish*

Right from the start of your project, we will help with the planning process, find the perfect system to suit your requirements and draw up a reliable cost calculation. Once the contract has been accepted, we will take care of the work and the detailed planning, site measurement and installation. Depending on certain conditions, we will even see the project through to the end on site. Our team of estimators, engineers and planners work hand in hand - and you will have a single, dedicated point of contact to talk you through every stage of the project. That's what "everything from a single source" means to us.

# BENEFITS FOR ARCHITECTS

*Creative freedom meets functional security*

At Solarlux, a high degree of creative freedom in building facade design goes hand in hand with the functional benefits of balcony and facade glazing. As a material, glass offers countless possibilities for architectural design, along with structural advantages such as sound, wind and weather protection. With curtain-hung facade elements, a wide range of system solutions and a variety of colours, the design possibilities are endless. Solutions from Solarlux are always multi-dimensional.



SL 35 / BASEL, SWITZERLAND / REF. NO. 00361

## FUNCTION

- Individual sound insulation solutions
- Protection from wind and weather; solutions for extreme wind loads
- Space gain thanks to thermally insulated systems

## DESIGN

- Curtain-hung or mounted facade solutions
- High-quality, durable materials, such as glass, aluminium and wood/aluminium
- All colours and special lacquers come with a GSB and Qualicoat-certified coating, even in demanding climate conditions
- All-glass, flexible glass solutions and slide-and-turn systems

## PORTFOLIO

- Slide-and-turn systems, bi-folding doors or sliding elements with maximum transparency, depending on requirements
- Complete facade modules or individual elements
- All solutions domestically and internationally certified

## PLANNING SUPPORT

Time is an important resource in complex building projects. In order to quickly achieve the best result using our wide variety of systems, we maintain a regular dialogue and hold solution-orientated discussions. Depending on your requirements, this can take place in person or with the assistance of various planning tools.

## DIGITAL SUPPORT

- BIM data: Generated via an interface in cooperation with BIMsystems; individual BIM data also available as IFC files on demand
- mySolarlux: CAD details, structural joints, sample configurations and other technical planning documents for all Solarlux systems on protected portal, mysolarlux.com
- SPACES: Documentation of over 600 projects in our web-based reference database with numerous filter options, i.e. by building type

## PERSONAL DIALOGUE

Our worldwide network of architects and property consultants offers support either in-person or by phone throughout every phase of the planning process. Whether you have questions about structural joints, structural analysis or sound insulation, energy efficiency, general feasibility or costs - with our expertise we always find a solution.

## BENEFITS FOR HOUSING COMPANIES

*Luxurious residential construction or energy renovation – experience counts*

We have been working intensively on balcony and facade design for more than 30 years, with a plethora of successfully completed projects of various sizes to our name both in Germany and abroad. From luxury apartment complexes to the energy renovation of residential towers, we know what matters – and that these requirements can vary, from one project to the next:

### CREATING ATTRACTIVE LIVING SPACE WITH NEW BUILDS

- Development of urban new-build areas in so-called “problem locations”, thanks to effective sound insulation using glass (“double-skin facade”)
- Densification of existing residential areas
- Increasing the attractiveness of properties with high-quality system solutions
- Space gain thanks to highly heat-insulated glazed balconies with wide opening options
- Award-winning, high-end solutions for discerning renters and buyers

### BINDING COST CALCULATION AND SCHEDULING

Our systems can be used in a modular fashion. We supply complete facade elements, balcony balustrades and individual elements alike. From the very beginning, we determine the exact requirements and reliably calculate the costs and production and installation times.

We offer:

- Precise, detailed work planning
- Internal production control for smooth processes
- Quick installation times, thanks to elements with a high degree of pre-fabrication
- Complete on-site installation without the need for elaborate customisation – country-specific and based on detailed prior agreement

### INCREASING VALUE THROUGH ENERGETIC RENOVATION

- Prevention of empty rental properties
- Increased residential value thanks to sound insulation and increased balcony usability
- Protection of the building fabric using curtain-hung facades
- Reduced energy costs, as glazed balconies act as a “climate buffer”



## BENEFITS FOR GENERAL CONTRACTORS AND DEVELOPERS

*A reliable partner  
at every stage of the project*

With us, you get everything from a single source. This approach provides assurance at every stage of your project. Our decades of experience in the handling of major construction sites at home and abroad make us a reliable partner. The entire process, from cost calculation to support with acceptance on the construction site, is overseen by us. With Solarlux as your partner, you can rely on:

- Reliable cost calculation
- Detailed, reliable scheduling, taking into account any special considerations, such as difficult installation situations,
- Detailed work planning, if required
- In-house logistics with our large Solarlux fleet
- State-of-the-art cranes and lifting equipment, provided by a certified contractor if necessary
- Elements with a high degree of pre-fabrication
- Certified system quality
- Quick installation by Solarlux installers or certified contractors
- Joint acceptance



State-of-the-art cranes guarantee smooth installation for larger zero elements, even in complex installation situations. Internationally, we draw on a network of qualified partners.





PAST AND  
FUTURE -  
WE RESPECT  
*both*

ABOUT SOLARLUX



SOLARLUX CAMPUS / MELLE, GERMANY

**EMBODYING OUR CORPORATE CULTURE:  
WITH ITS OPEN ARCHITECTURE, THE SOLARLUX  
CAMPUS NEVER FAILS TO IMPRESS**

## A SPECIAL FAMILY-OWNED COMPANY

*Down-to-earth, innovative and passionate*

For more than 35 years, Solarlux has represented exceptional quality in the production of bi-folding doors, wintergardens and facade solutions. Founded by Herbert Holtgreife and based in the town of Melle, north-west Germany, the company is now managed by Holtgreife's son, Stefan. But the real driving force behind Solarlux is its employees: A workforce of around 1,000 dedicated, imaginative men and women is vital for the success of the family company.

## EXPERIENCE THE PRODUCTS LIVE

*Our showroom*

Our almost 3,000-m<sup>2</sup> showroom at our German headquarters offers exclusive balcony and facade solutions, as well as glazed extensions such as wintergardens and glass canopies. Here, you can find out all about the quality and the wide range of possibilities offered by Solarlux in real application situations. We also display our product solutions at various showrooms in other national and international locations.

### *International sites*

**SOLARLUX AUSTRIA GMBH (OFFICE)**  
Grabenweg 64 · 6020 Innsbruck  
T +43 512 209023

**SOLARLUX ESPAÑA S.L.**  
Calle de Téllez nº 27 · 28007 Madrid  
+34 93 760 9471

**SOLARLUX FRANCE SARL**  
145 Avenue du 12 juillet 1998 Bat. B08  
13290 Aix en Provence  
T +33 442 673099

**SOLARLUX NEDERLAND BV**  
Marie Curiestraat 2 · 7442 DP Nijverdal  
T +31 548 631323

**SOLARLUX SCANDINAVIA AB**  
Grimsbygatan 24 · 211 20 Malmö  
T +46 40 456190

**SOLARLUX (SCHWEIZ) AG**  
Dellenbodenweg 5 · 4452 Itingen  
T +41 61 9269191

**SOLARLUX SYSTEMS LTD., UK**  
Unit 5, Quadrant Park  
Hertfordshire, AL7 1FS  
T +44 1707 339970

**NANA WALL SYSTEMS, INC., USA**  
100 Meadowcreek Drive #250  
94925 Corte Madera  
T +1 800 873 5673

### *German sites*

**HAMBURG (OFFICE)**  
Jessenstrasse 10 · 22767 Hamburg  
T +49 174 3368068

**MELLE (HEAD OFFICE)**  
Industriepark 1 · 49324 Melle  
T +49 174 3368006

**KAUFBEUREN**  
Innovapark 21 · 87600 Kaufbeuren  
T +49 174 3368057 (Linara GmbH)

**MUNICH**  
Designerwerkschau · Fruchthof München  
Gotzinger Strasse 52b · 81371 Munich  
T +49 174 3368049

**MÜNSTER**  
Weseler Str. 253 · 48151 Münster  
T +49 174 3368006

**NUREMBERG**  
Grossreuther Strasse 70 · 90425 Nuremberg  
T +49 174 1580343 (Schultheiß Projekt-entwicklung AG)

**STUTTGART**  
raumPROBE Stuttgart  
Dieselstrasse 32 · 70469 Stuttgart  
T +49 151 29262156

**WIESBADEN (OFFICE)**  
Dantestrasse 33 · 65189 Wiesbaden  
T +49 151 29262156

# REFERENCE LIST

## *An overview of our projects*

The list below contains all the references in this brochure, listed in chronological order. Should you have any questions about the projects, please quote the specified reference number.

PAGE	NAME	SYSTEM	ARCHITECT	COUNTRY	REF. NO.
1 - 5, 12	"The George" in Amsterdam	Highline	Dok Architecten	The Netherlands	01327
6	Apartment building in London	SL 25	-	England	00821
8-9	Apartment building in Leiden	SL 35	Groosmann, Rotterdam	The Netherlands	00455
10 left	Apartment building in New Brighton	SL 25	FCH Falconer Chester Hall Architects (GB)	England	01301
10 right	Apartment building in Hamburg	SL 25 Modular	APB. Architekten BDA Grossmann-Hensel Schneidern Andresen	Germany	01403
11	Apartment building in Ulm	SL 25	Braunger Wörtz Architekten, Ulm	Germany	01094
13-15, 68	Apartment building in Leipzig	SL 25 Modular	S&P Sahlmann Planungsgesellschaft, Leipzig	Germany	01125
16	Apartment building in Pforzheim	SL 60e Modular	-	Germany	00119
19-21	Neustadt Carré in Osnabrück	Ecoline	PLAN.CONCEPT Architekten GmbH	Germany	01417
24, 25	Apartment building in Berlin	Woodline	zanderrotharchitekten	Germany	00327
28-29	Tasman Toren Groningen	SL 60e Modular	WAL Architects Groningen, NL	The Netherlands	00110
30-31	Apartment building in Hamburg	SL 81 Modular	-	Germany	01067
33	Zeewolde	Ecoline Modular	HBN Architecten	The Netherlands	01590
34-37	Apartment building in Lübeck	SL 25 Modular	Architekturbüro Wolfgang Kriese	Germany	01435

PAGE	NAME	SYSTEM	ARCHITECT	COUNTRY	REF. NO.
38-39	Apartment building in Dublin	SL 25	Seán Harrington Architects	Ireland	00020
41	Apartment building in Hamburg-Lurup	SL 25R Modular	LRW Loosen, Rüschoff + Winkler - Architekten (Planning), KBNK Architekten GmbH (Construction Management)	Germany	01591
43	Apartment building in Haar	SL 20	bogevischs buero	Germany	01598
44	Apartment building in Nantes	SL 23	Brenac & Ganzalez & Associés	France	01406
46-47	Apartment building in Hamburg	SL 25 Modular	APB. Architekten BDA Grossmann-Hensel Schneidern Andresen	Germany	01403
48	Apartment building in Schwanewede	SL Plus	M-Projekt	Germany	01734
50-51	Apartment building in Hamburg	SL 25 Modular	KBNK Architekten GmbH, Hamburg	Germany	01267
52, 56-57	New forum in Hamburg-Altona	SL access balcony glazing	nps, Hamburg	Germany	00697
54-55	Langenhorner Chaussee	SL access balcony glazing	Rüdiger Nickel Architekten	Germany	01593
58	Residential and office building in Potsdam	cero III	Scheidt Kasprusch Architekten	Germany	01720
60-61	Holiday homes in Binz on Rügen	cero III	Prora Solitaire Immobilien GmbH	Germany	01335
62	Hotel Sand, Timmendorfer Strand	cero III	Falk Planungsbüro, Lübeck	Germany	01586
67	Lofthaus Molenpark in Offenbach	cero III	bb22 Architekten + Stadtplaner	Germany	01704
106	St. Jakob Tower	SL 35	Herzog + de Meuron	Switzerland	00361

# REFERENCE DATABASE SPACES ONLINE

## *Project reports & documentation*

Over 600 project documents are available online on our web-based, browser-independent reference database "Spaces". The systematic search functionality provides inspiration by allowing users to search for specific building typologies, Solarlux systems or locations. By clicking on the links provided, users can view more detailed project reports and information on the product range and products used, as well as technical information: <https://spaces.solarlux.com>



Scan the code to visit the  
"Spaces" reference database



