

Einbauanleitung	DE
Installation instructions	EN
Notice de montage	FR
Montage-instructies	NL
Instrukcja montażu	PL
Инструкция по монтажу	RU
Montaj talimatı	TR

SitaCompact SitaCarport

Sita Bauelemente GmbH

Ferdinand-Braun-Str. 1
33378 Rheda-Wiedenbrück

T +49 2522 8340-0

E info@sita-bauelemente.de

W sita-bauelemente.de



Stand: 06.2024

Technische Änderungen, auch ohne Ankündigung, vorbehalten.



Inhalt

1.	Über diese Anleitung	4
1.1	Einleitung	4
1.2	Mitgeltende Dokumente	4
2.	Sicherheit	4
2.1	Bestimmungsgemäße Verwendung	4
2.2	Fehlgebrauch	4
2.3	Personalanforderung	4
2.4	Restrisiken	4
2.5	Anforderung an den Montageort	4
2.6	Persönliche Schutzausrüstung	4
3.	Montage	17
3.1	SitaCompact Dämmkörper Gully	25
3.1.1	SitaCompact senkrecht	29
3.1.2	SitaCompact Schraubflansch	32
3.2	SitaCompact abgewinkelt	36
3.3	SitaCompact Aufstockelement	41
3.4	SitaCompact Fluid	46
3.5	SitaCompact Anstaurung	57
3.6	SitaCompact Balkonaufsatz	62
3.7	SitaCarport	67



1. Über diese Anleitung

1.1 Einleitung

Diese Einbauanleitung gibt einen Überblick über den Einbau von Bauteilen zur Flachdachentwässerung.

1.2 Mitgeltende Dokumente

Vor Beginn aller Arbeiten die zugehörigen Dokumente hinzuziehen, lesen und beachten:

- o Verlegeanleitung des jeweiligen Dach- und Abdichtungsbahnherstellers
- o Sicherheitsdatenblätter der Dicht- und Klebstoffe

Weiter müssen u. a. folgende Normen und Richtlinien beachtet werden: DIN EN 12056-3, DIN 1986-3, DIN 1986-100, DIN 18531, DIN 18234, Flachdachrichtlinie

2. Sicherheit

2.1 Bestimmungsgemäße Verwendung

Dachgullys zur Flachdachentwässerung dienen ausschließlich der Ableitung von Niederschlagswasser von genutzten und ungenutzten Flachdächern in das zugehörige Entwässerungssystem des Gebäudes.

- o Alle Anforderungen an den Montageort müssen erfüllt sein.
- o Ausschließlich wie in der Einbauanleitung beschrieben einbauen.
- o Entwässerungssystem stets gemäß Berechnungsnachweis dimensionieren.
- o Angeschlossene Rohrleitungen ggf. mit geeigneten Maßnahmen gegen Tauwasserbildung schützen.
- o Bei Bitumenmanschetten Trennfolie abflämmen.
- o Bitumenbahn bei Schraubflanschkonstruktionen bis zur Einlaufkante führen und direkt auf den Festflansch des Ablaufkörpers aufschweißen.

2.2 Fehlgebrauch



Warnung! Gefahr durch Fehlgebrauch!

- Fehlgebrauch des Dachgullys kann zu Leckagen bis hin zur unzureichenden Entwässerung des Gebäudes und somit zur statischen Überlastung führen.
- o Niemals eigenmächtige Umbauten an dem Entwässerungssystem vornehmen.
 - o Niemals Dachgullys ohne entsprechende Ummantelung einbetonieren.
 - o Dachgully niemals überbauen.
 - o Bei bituminösen Abdichtungen:
 - o niemals Dichtmanschetten verwenden.
 - o Festflansch des Ablaufkörpers mit Bitumen- voranstrich vorstreichen.
 - o Niemals Nahtüberdeckung im Flanschbereich herstellen.
 - o Niemals vlieskaschierte Dachbahnen einflanschen.
 - o Verträglichkeit der Dichtungen bei Schraubflansch- Konstruktionen zum Dachabdichtungsmaterial prüfen.

2.3 Personalanforderungen



- #### Warnung! Unfallgefahr bei unzureichender Qualifikation
- Wenn Arbeiten durch unzureichend qualifizierte Personen durchgeführt werden, besteht Unfallgefahr.
- o Alle Tätigkeiten nur durch Personen durchführen lassen, die die im folgenden genannten Qualifikationen besitzen.

Fachkundige Person



Die fachkundige Person ist aufgrund ihrer Ausbildung und/oder langjähriger Erfahrung in der Lage die Montage je nach Einbausituation ordnungsgemäß durchzuführen. Des Weiteren kennt und beachtet sie einschlägige Normen und Richtlinien zur Dachentwässerung und Dachabdichtung und ist in der Lage Gefahren und Einbaufehler selbstständig zu erkennen und zu vermeiden.

2.4 Restrisiken



Absturz

Warnung!

Unfallgefahr durch Höhenarbeiten.

- Beim Arbeiten auf Dächern, Plattformen, Leitern oder Gerüsten kann es durch unvorsichtiges Vorgehen zum Absturz kommen.
- o Bei allen Höhenarbeiten stets persönliche Schutzausrüstung tragen.
 - o Stets mit geeigneten Mitteln gegen Absturz sichern.
 - o Bei allen Arbeiten auf sicheren Stand achten.
 - o Niemals weit über Leitern oder Brüstungen hinauslehnen.
 - o Zusätzlich stets die jeweiligen Unfallverhütungsvorschriften beachten.



Ersatzteile

Hinweis!

Beschädigungsgefahr durch falsche Ersatzteile.

- Verwendung falscher Ersatzteile kann zu Leckagen bis hin zur unzureichenden Entwässerung des Gebäudes und somit zur statischen Überlastung führen.
- o Ausschließlich die vom Hersteller freigegebenen Ersatzteile verwenden.

2.5 Anforderungen an den Montageort

- Der Montageort muss folgende Anforderungen erfüllen:
- o Der Montageort muss ausreichend abgesperrt werden.
 - o Der Montageort muss sauber und trocken sein.
 - o Durchdringungen den statischen Anforderungen mit Verstärkungsblechen anpassen.

2.6 Persönliche Schutzausrüstung

Die im Folgenden aufgeführte Schutzausrüstung stets bereithalten und tragen.



Schutzhelm



Schutzhand-
schuhe



Absturz-
sicherung



Arbeitsschutz-
kleidung



Gehörschutz



Schutzbrille



Contents

1.	About these instructions	6
1.1	Introduction	6
1.2	Other relevant documents	6
2.	Safety	6
2.1	Permitted use	6
2.2	Non-permitted use	6
2.3	Workforce requirements	6
2.4	Residual hazards	6
2.5	Assembly location requirements	6
2.6	Personal protective equipment	6
3.	Assembly	17
3.1	SitaCompact insulating body outlet	25
3.1.1	SitaCompact vertical	29
3.1.2	SitaCompact screw-on flange	32
3.2	SitaCompact angled	36
3.3	SitaCompact extension element	41
3.4	SitaCompact Fluid	46
3.5	SitaCompact retaining ring	57
3.6	SitaCompact balcony grating	62
3.7	SitaCarport	67



1. About these instructions

1.1 Introduction

These installation instructions provide an overview of the installation of parts for flat roof drainage.

1.2 Other relevant documents

Before starting any work, consult, read and observe the relevant documents:

- o Laying instructions of the specific roofing and sealing membrane manufacturer
- o Safety data sheets of sealants and adhesives

The following standards and guidelines must also be observed: DIN EN 12056-3, DIN 1986-3, DIN 1986-100, DIN 18531, DIN 18234, Flat Roof guideline (Flachdachrichtlinie)

2. Safety

2.1 Permitted use

Roof outlets for flat roof drainage are designed exclusively to discharge rainfall from used and unused flat roofs to the associated drainage system of the building.

- o All assembly location requirements must be met.
- o The systems must only be installed as described in the installation instructions.
- o The drainage system must always be sized according to the calculation documentation.
- o Connected pipes may require suitable measures to protect against condensation.
- o The separation film in bitumen sleeves must be burnt off.
- o Lead the bitumen membrane to the inlet edge and weld it directly onto the fixed flange of the drain body.

2.2 Non-permitted use



Warning!

Danger from non-permitted use.

Non-permitted use of the roof outlet may result in leaks and even inadequate drainage of the building, resulting in structural overload.

- o Never make unauthorised changes to the drainage system.
- o Never embed pipes in concrete without a suitable lining.
- o Never build on top of the roof outlet.
- o With bituminous seals:
 - o Never use sealing sleeves.
 - o Pre-coat the fixed flange of the drain body with bitumen pre-coating.
- o Never use a seam overlap in the flange area.
- o Never flange in roofing membranes with a lining of non-woven fabric.
- o Check that the seals in screw-on flange constructions are compatible with the roofing membrane material.

2.3 Workforce requirements



Warning!

Risk of accidents if the workforce is insufficiently qualified

If work is carried out by insufficiently qualified persons there is a risk of accidents.

- o Only allow persons to carry out activities if they have the qualifications indicated below.

Competent person



The competent person has the education and/or many years of experience allowing him or her to carry out assembly correctly according to the installation situation. He or she is also familiar with and complies with the relevant standards and guidelines concerning flat roof drainage and roofing membranes and is able independently to recognise and avoid dangers and installation errors.

2.4 Residual hazards



Falling

Warning!

Risk of accidents while working at height.

When work is carried out on roofs, platforms, ladders or scaffold, falls may occur if care is not taken.

- o When working at height, always wear personal protection equipment.
- o Always take suitable measures to protect against falling.
- o For all work, make sure there is a stable base.
- o Never lean out far over ladders or parapets.
- o In addition, always observe the relevant accident prevention regulations.



Spare parts

Note.

Risk of damage due to incorrect spare parts.

The use of incorrect spare parts may result in leaks and even inadequate drainage of the building, resulting in structural overload.

- o Only use spare parts which are approved by the manufacturer.

2.5 Assembly location requirements

The assembly location must meet the following requirements:

- o The assembly location must be adequately cordoned off.
- o The assembly location must be clean and dry
- o Use reinforcement plates to ensure that penetrations meet structural requirements.

2.6 Personal protective equipment

Always keep available and wear the protective equipment listed below.



Protective helmet



Protective gloves



Fall protection



Protective clothing



Hearing protection



Protective goggles



Table des matières

1.	À propos de cette notice de montage	8
1.1	Introduction	8
1.2	Documents applicables	8
2.	Sécurité	8
2.1	Utilisation conforme à l'usage prévu	8
2.2	Mauvaise utilisation	8
2.3	Exigence en matière de personnel	8
2.4	Risques résiduels	8
2.5	Exigence relative au lieu de montage	8
2.6	Équipement de protection individuelle	8
3.	Montage	17
3.1	SitaCompact pièce d'isolation pour avaloir	25
3.1.1	SitaCompact sortie verticale	29
3.1.2	SitaCompact Bride à visser	32
3.2	SitaCompact sortie coudée	36
3.3	SitaCompact rehausse	41
3.4	SitaCompact Fluid	46
3.5	SitaCompact trop-plein	57
3.6	SitaCompact Couronnement et grille pour balcon	62
3.7	SitaCarport	67



1. À propos de cette notice de montage

1.1 Introduction

Cette notice de montage fournit une vue d'ensemble de la pose de composants pour l'évacuation des toitures plates.

1.2 Documents applicables

Avant le début de toute intervention, consulter, lire et tenir compte des documents correspondants :

- o Notice de pose du fabricant de la membrane de toit et de la membrane d'étanchéité
- o Fiche de données de sécurité des colles et des mastics

Il convient également de tenir compte des normes et directives suivantes : NBN EN 12056-3, DIN 1986-3, DIN 1986-100, DIN 18531, DIN 18234, directive relative aux toits plats.

2. Sécurité

2.1 Utilisation conforme à l'usage prévu

Les avaloirs de toiture pour l'évacuation de toitures plates servent exclusivement à l'évacuation des eaux pluviales de toitures plates exploitées ou inexploitées dans le système d'évacuation du bâtiment.

- o Il convient de respecter toutes les exigences relatives au lieu de montage.
- o Effectuer la pose uniquement de la manière décrite dans la notice de montage.
- o Toujours dimensionner le système d'évacuation conformément aux calculs effectués par Sita.
- o Si nécessaire, protéger les conduites raccordées contre le gel et la condensation par des mesures appropriées.
- o Souder à la flamme la feuille de séparation des manchons bitumineux.
- o Guider la membrane bitumineuse des constructions à bride à visser jusqu'au bord de l'écoulement et la fixer directement par soudage sur la bride fixe du corps d'écoulement.

2.2 Mauvaise utilisation



Avertissement!

Danger dû à une mauvaise utilisation!

Une mauvaise utilisation de l'avaloir de toiture peut entraîner des fuites, pouvant aller jusqu'à une évacuation insuffisante du bâtiment et générer ainsi une surcharge statique.

- o Ne jamais procéder à des modifications non autorisées du système d'évacuation.
- o Ne jamais bétonner des avaloirs de toiture sans gaine adaptée.
- o Ne jamais construire sur un avaloir de toiture.
- o Pour réaliser une étanchéité bitumineuse :
 - o Ne jamais utiliser de manchons d'étanchéité.
 - o Appliquer un apprêt bitumineux sur la bride fixe du corps d'écoulement.
- o Ne jamais faire chevaucher les joints au niveau de la bride.
- o Ne jamais utiliser de bride pour les membranes de toiture en non-tissé polyester.
- o Vérifier la compatibilité des joints sur les constructions à bride à visser pour le matériau d'étanchéité de toiture.

2.3 Exigences en matière de personnel



Avertissement!

Risque d'accident en cas de qualification insuffisante

Si les travaux sont effectués par des personnes sous-qualifiées, il y a un risque d'accident.

- o Toutes les interventions doivent être uniquement effectuées par des personnes possédant les qualifications mentionnées ci-après.

Personne qualifiée



Par sa formation et/ou ses nombreuses années d'expérience, la personne qualifiée est en mesure de réaliser correctement le montage, en fonction du cas de figure. En outre, elle connaît et respecte les normes et directives relatives à l'évacuation des eaux de toiture et à l'étanchéité de toiture. Elle est également capable d'identifier et d'éviter les risques et les erreurs de montage.

2.4 Risques résiduels



Chute de hauteur

Avertissement!

Risque d'accident dû au travail en hauteur.

Lors d'une intervention sur un toit, une plate-forme, une échelle ou un échafaudage, le manque de précautions peut entraîner une chute.

- o Toujours porter un équipement de protection individuelle lors de tout travail en hauteur.
- o Toujours utiliser des moyens appropriés pour se protéger contre les chutes.
- o Veiller à la stabilité du support lors de toute intervention.
- o Ne jamais trop se pencher au-dessus d'une échelle ou d'une balustrade.
- o Toujours respecter également les règles en vigueur en matière de prévention des accidents.



Pièces de rechange

Note!

Risque de dommages dus à des pièces de rechange incorrectes.

L'utilisation de pièces de rechange incorrectes peut entraîner des fuites, pouvant aller jusqu'à une évacuation insuffisante du bâtiment, et générer ainsi une surcharge statique.

- o Utiliser uniquement les pièces de rechange approuvées par le fabricant.

2.5 Exigences à respecter sur le lieu de montage

Le lieu de montage doit répondre aux exigences suivantes:

- o Le lieu de montage doit être correctement délimité.
- o Le lieu de montage doit être propre et sec.
- o Utiliser des tôles de renfort pour adapter les percements aux exigences statiques.

2.6 Équipement de protection individuelle

Toujours garder à portée de main et porter les équipements de protection énumérés ci-dessous.



Casque de protection



Gants de sécurité



Dispositif antichute



Vêtements de travail de sécurité



Protections auditives



Lunettes de protection



Inhoud

1.	Over deze handleiding	10
1.1	Inleiding	10
1.2	Geldende documenten	10
2.	Veiligheid	10
2.1	Gebruik volgens de voorschriften	10
2.2	Foutief gebruik	10
2.3	Aan personeel gestelde eisen	10
2.4	Overige risico's	10
2.5	Aan de montageplaats gestelde eisen	10
2.6	Persoonlijke beschermingsmiddelen	10
3.	Bevestiging	17
3.1	SitaCompact isolatieblok dakkolk	25
3.1.1	SitaCompact verticaal	29
3.1.2	SitaCompact met schroefflens	32
3.2	SitaCompact gebogen	36
3.3	SitaCompact verhogingselement	41
3.4	SitaCompact Fluid	46
3.5	SitaCompact overloop	57
3.6	SitaCompact balkonopzetframe	62
3.7	SitaCarport	67



1. Over deze handleiding

1.1 Inleiding

Deze installatiehandleiding geeft een overzicht van de installatie van onderdelen voor afwatering van platte daken.

1.2 Geldende documenten

Vóór aanvang van alle werkzaamheden de bijbehorende documenten raadplegen, lezen en in acht nemen:

- o Plaatsingsvoorschriften van de betreffende fabrikant van de dakbedekking en dakdichtingsbanen
- o Veiligheidsinformatiebladen van de afdichtingsstoffen en lijmen

Verder moeten onder meer de volgende normen en richtlijnen in acht worden genomen: DIN EN 12056-3, DIN 1986-3, DIN 1986-100, DIN 18531, DIN 18234, Richtlijn platte daken

2. Veiligheid

2.1 Gebruik volgens de voorschriften

Dakkolken voor afwatering van platte daken dienen uitsluitend voor het afvoeren van neerslagwater van gebruikte en ongebruikte platte daken naar het bijbehorende afwateringssysteem van het gebouw.

- o Aan alle aan de montageplaats gestelde eisen moet zijn voldaan.
- o Uitsluitend inbouwen zoals in de inbouwhandleiding beschreven.
- o Afwateringssysteem altijd volgens de gedocumenteerde berekeningen dimensioneren.
- o Aangesloten buizen zo nodig met passende maatregelen tegen vorming van dooiwater beschermen.
- o Bij bitumenmanchetten scheidingsfolie afvlammen.
- o Bitumenbaan bij schroefflensconstructies tot de inlooprand geleiden en direct op de vaste flens van het afvoerlichaam vastlassen.

2.2 Foutief gebruik



Waarschuwing!

Gevaar door verkeerd gebruik!

- Verkeerd gebruik van het afvoersysteem van het dak kan leiden tot lekken en zelfs tot onvoldoende afwatering van het gebouw en dus tot statische overbelasting.
- o Breng nooit ongeoorloofde wijzigingen aan in het afvoersysteem.
 - o Dakafvoeren nooit in beton verankeren zonder passende bekleding.
 - o Bouw nooit over dakafvoeren heen.
 - o Bij bitumineuze afdichtingen:
 - o Gebruik nooit afdichtkragen.
 - o De vaste flens van het afvoerlichaam voorlakken met bitumenvoorstrijk.
 - o Bedek nooit de naad in het flensgebied.
 - o Vliesgelamineerde dakbanen nooit invouwen.
 - o Controleer compatibiliteit van afdichtingen bij schroefflensconstructies met dakafdichtingsmateriaal.

2.3 Aan personeel gestelde eisen



Waarschuwing!

Gevaar voor ongevallen door onvoldoende gekwalificeerd personeel.

- Als werkzaamheden worden uitgevoerd door onvoldoende gekwalificeerd personeel, bestaat gevaar voor ongevallen.
- o Laat alle werkzaamheden alleen uitvoeren door personen die over de volgende kwalificaties beschikken.

Deskundige persoon



De deskundige persoon is op basis van zijn opleiding en/of meerdere jaren ervaring in staat om de montage afhankelijk van de inbouwsituatie volgens de voorschriften uit te voeren. Daarnaast kent hij relevante normen en richtlijnen voor dakafwatering en dakafdichting en volgt hij deze op en is hij in staat gevaren en inbouwfouten zelfstandig te herkennen en te voorkomen.

2.4 Overige risico's



Vallen

Waarschuwing!

Gevaar voor ongevallen door werken op hoogte.

- Bij werkzaamheden op daken, platforms, ladders of steigers kan door onvoorzichtig handelen een val worden veroorzaakt.
- o Bij alle werkzaamheden op hoogte altijd de persoonlijke beschermingsmiddelen dragen.
 - o Altijd met hiervoor bedoelde middelen tegen vallen beveiligen.
 - o Bij alle werkzaamheden op stevig staan letten.
 - o Nooit ver over ladders of borstweringen leunen.
 - o Altijd de geldende voorschriften ter voorkoming van ongevallen opvolgen.



Vervangende onderdelen

Aanwijzing!

Gevaar voor beschadiging door verkeerde vervangende onderdelen.

- Gebruik van verkeerde vervangende onderdelen kan lekkages en onvoldoende afwatering van het gebouw en daardoor permanente overbelasting veroorzaken.
- o Uitsluitend door de fabrikant goedgekeurde vervangende onderdelen gebruiken.

2.5 Aan de montageplaats gestelde eisen

De montageplaats moet aan de volgende eisen voldoen:

- o De montageplaats moet voldoende worden afgezet.
- o De montageplaats moet schoon en droog zijn.
- o Doorbrekingen met versterkingsplaten aan de statische eisen aanpassen.

2.6 Persoonlijke beschermingsmiddelen

De hierna genoemde beschermingsmiddelen altijd paraat hebben en dragen.



Veiligheidshelm



Beschermende handschoenen



Valbescherming



Veiligheidskleding



Gehoorscherming



Veiligheidsbril



Spis treści

1.	Informacje o tej instrukcji obsługi	12
1.1	Wstęp	12
1.2	Dokumenty powiązane	12
2.	Bezpieczeństwo	12
2.1	Użycie zgodne z przeznaczeniem	12
2.2	Nieprawidłowe użycie	12
2.3	Wymagania dla personelu	12
2.4	Ryzyko resztkowe	12
2.5	Wymagania dla miejsca montażu	12
2.6	Środki ochrony indywidualnej	12
3.	Montaż	17
3.1	SitaCompact korpus izolacyjny	25
3.1.1	SitaCompact pionowy	29
3.1.2	SitaCompact kołnierz zaciskowy	32
3.2	SitaCompact skośny	36
3.3	SitaCompact element nadbudowy	41
3.4	SitaCompact Fluid	46
3.5	SitaCompact pierścień spiętrzający	57
3.6	SitaCompact nasadka balkonowa	62
3.7	SitaCarport	67



1. Informacje o tej instrukcji obsługi

1.1 Wstęp

Niniejsza instrukcja zawiera opis montażu poszczególnych elementów systemu odwadniania dachu płaskiego.

1.2 Dokumenty powiązane

Przed rozpoczęciem jakichkolwiek prac należy przeczytać, zrozumieć i wykonać zalecenia zawarte w:
o Instrukcjach zakładania membran dachowych i hydroizolacyjnych wydanych przez ich producentów
o Kartach charakterystyki materiałów uszczelniających i klejów
Ponadto należy przestrzegać następujących norm i dyrektyw: DIN EN 12056-3, DIN 1986-3, DIN 1986-100, DIN 18531, DIN 18234, Wytyczne dotyczące dachów płaskich

2. Bezpieczeństwo

2.1 Użycie zgodne z przeznaczeniem

Wpusty dachowe do odwadniania dachów płaskich służą wyłącznie do odprowadzania wody opadowej z używanych i nieużywanych dachów płaskich do właściwego systemu odwadniania budynku.
o Wszystkie wymagania dla miejsca montażu muszą być spełnione.
o Montaż wykonać ściśle zgodnie z opisem w instrukcji.
o System odwadniania zwymiarować zgodnie ze zweryfikowanymi obliczeniami.
o Podłączone orurowanie w razie potrzeby zabezpieczyć odpowiednimi środkami przed wodą z roztopów.
o W przypadku bitumicznych kołnierzy uszczelniających wypalić folię separującą
o W przypadku konstrukcji z kołnierzami przykręcanymi podciągnąć membranę bitumiczną do krawędzi wlotowej i zgrażać bezpośrednio ze stałym kołnierzem korpusu odpływu.

2.2 Nieprawidłowe użycie



Ostrzeżenie!
Niebezpieczeństwo z powodu niewłaściwego użytkowania!

Nieprawidłowe wykorzystanie systemu odwadniania dachu może prowadzić do nieszczelności, a nawet do niedostatecznego odwodnienia budynku i do jego przeciążenia statycznego.
o Nigdy nie wprowadzać samowolnych zmian w systemie odwadniającym.
o Nigdy nie osadzać wpustów dachowych w betonie bez odpowiedniej osłony
o Nigdy nie zabudowywać żadnych elementów nad wpustami dachowymi.
o W przypadku hydroizolacji bitumicznych:
o nigdy nie stosować kołnierzy uszczelniających.
o Kołnierz stały korpusu odpływu pomalować wstępnie bitumem.
o Nigdy nie zakrywać szwu w obszarze kołnierza.
o Nigdy nie składać membran dachowych laminowanych włókniną.
o Sprawdzić kompatybilność uszczelnień w konstrukcjach z przykręcanymi kołnierzami z materiałem uszczelnienia dachu.

2.3 Wymagania dla personelu



Ostrzeżenie!
Niebezpieczeństwo wypadku w przypadku niewystarczających kwalifikacji

W przypadku wykonywania prac przez osoby o niewystarczających kwalifikacjach istnieje niebezpieczeństwo wypadku.
o Wszystkie prace muszą być wykonywane wyłącznie przez osoby mające poniższe kwalifikacje.

Personel wykwalifikowany



Personel wykwalifikowany są to osoby, które ze względu na swoje wykształcenie i/lub wieloletnie doświadczenie są w stanie prawidłowo wykonać montaż odpowiednio do panujących warunków. Ponadto osoby te muszą znać właściwe normy i przepisy dotyczące odwadniania i uszczelnienia dachów oraz ich przestrzegać, a także być w stanie samodzielnie rozpoznać niebezpieczeństwo i błędy montażu i unikać ich.

2.4 Ryzyko resztkowe



Upadek z wysokości

Ostrzeżenie!

Niebezpieczeństwo wypadku z powodu prac prowadzonych na wysokości. Podczas prac na dachach, pomostach, drabinach lub rusztowaniach nieostrożne postępowanie może spowodować upadek z wysokości.
o Podczas wszystkich prac na wysokości należy zawsze stosować środki ochrony indywidualnej.
o Zawsze stosować odpowiednie zabezpieczenia przed upadkiem z wysokości.
o Podczas wszystkich prac zwracać uwagę na bezpieczne oparcie ciała.
o Nigdy nie wychylać się za daleko z drabin ani za barierki.
o Ponadto zawsze przestrzegać właściwych przepisów dotyczących zapobiegania wypadkom.



Części zamienne

Uwaga!

Niebezpieczeństwo uszkodzeń z powodu użycia nieprawidłowych części zamiennych. Stosowanie nieprawidłowych części zamiennych może spowodować nieszczelności, a nawet niedostateczne odwodnienie budynku i jego przeciążenie statyczne.
o Stosować wyłącznie części zamienne dopuszczone przez producenta.

2.5 Wymagania dla miejsca montażu

Miejsce montażu musi być:
o odpowiednio wygradzone.
o czyste i suche.
o Przepusty należy dostosować do występujących obciążeń statycznych za pomocą blach wzmacniających.

2.6 Środki ochrony indywidualnej

Wymienione poniżej wyposażenie ochronne należy zawsze mieć przygotowane i używać.



Kask ochronny



Rękawice ochronne



Zabezpieczenie przed upadkiem z wysokości



Ubiór ochronny



Ochroniacze słuchu



Okulary ochronne



Содержание

1.	О данном руководстве	14
1.1	Введение	14
1.2	Применяемые документы	14
2.	Безопасность	14
2.1	Целевое применение	14
2.2	Нецелевое использование	14
2.3	Требование к персоналу	14
2.4	Остаточные риски	14
2.5	Требования к месту установки	14
2.6	Средства индивидуальной защиты	14
3.	Монтаж	17
3.1	Изоляционная плита SitaCompact для воронки	25
3.1.1	SitaCompact вертикальная	29
3.1.2	SitaCompact с фланцем	32
3.2	SitaCompact угловая	36
3.3	Надставной элемент SitaCompact	41
3.4	SitaCompact Fluid	46
3.5	Подпорный элемент SitaCompact	57
3.6	Балконная насадка SitaCompact	62
3.7	SitaCarport	67



1. О данном руководстве

1.1 Введение

В данной инструкции по монтажу приведен обзор порядка монтажа компонентов водостока с плоских кровель.

1.2 Применяемые документы

Перед началом любых работ необходимо найти, прочитать и учитывать соответствующие документы:

- o Инструкции по укладке кровельных и гидроизолирующих мембран соответствующих производителей
 - o Паспорта безопасности герметиков и клеев
- Необходимо соблюдать также следующие стандарты и рекомендации: Стандарты DIN EN 12056-3, DIN 1986-3, DIN 1986-100, DIN 18531, DIN 18234, руководство по плоским кровлям

2. Надежность

2.1 Целевое применение

- Системы кровельных воронок для водостока плоских кровель служат исключительно для отвода атмосферных осадков с эксплуатируемых и неэксплуатируемых плоских кровель в соответствующую водосточную систему здания.
- o Все требования к месту установки должны быть соблюдены.
 - o Монтаж выполнять только в соответствии с инструкцией по установке.
 - o Размеры водосточной системы всегда следует определять в соответствии с подтвержденным расчетом.
 - o При необходимости принять соответствующие меры по защите подключенных трубопроводов от замерзания и талой воды.
 - o При использовании битумных манжет разделительную пленку следует опалить.
 - o Битумную мембрану для резьбовых фланцевых конструкций подвести до края впускного отверстия и приварить непосредственно к фиксированному фланцу корпуса воронки.

2.2 Нецелевое использование



Внимание!

Опасность при нецелевом использовании!

Нецелевое использование кровельных воронок может привести к протечкам и даже к недостаточному водостоку со здания и, тем самым, к статической перегрузке.

- o Запрещается самовольно вносить изменения в систему водостока.
- o Запрещается обетонирование кровельных воронок без соответствующей оболочки.
- o Надстройки над кровельными воронками не допускаются.
- o Для битумной гидроизоляции:
 - o запрещается использовать уплотнительные манжеты.
 - o Неподвижный фланец корпуса воронки следует предварительно загрузить битумом.
- o Категорически не допускается перекрытие шва в зоне фланца.
- o Запрещается крепление на фланцах кровельных мембран, дублированных нетканым материалом.
- o Проверьте совместимость уплотнений в конструкциях с резьбовыми фланцами с кровельным уплотнительным материалом.

2.3 Требования к персоналу



Внимание! Опасность несчастного случая при недостаточной квалификации

- При выполнении работ недостаточно квалифицированными специалистами существует опасность несчастного случая.
- o Все виды работ разрешается выполнять только лицам, обладающим указанной ниже квалификацией.

Компетентный специалист



Благодаря своей подготовке и/или многолетнему опыту компетентный специалист способен правильно выполнить установку в зависимости от условий монтажа. Кроме того, он знает и соблюдает соответствующие стандарты и инструкции по водостоку и гидроизоляции кровли, а также способен самостоятельно распознать и избежать опасностей и ошибок при монтаже.

2.4 Остаточные риски



Падение

Внимание!

Опасность несчастного случая при высотных работах. При работах на кровлях, платформах, лестницах или строительных лесах неосторожные действия могут привести к падению.

- o При работах на высоте всегда использовать средства индивидуальной защиты.
- o Всегда предохранять себя от падения с помощью соответствующих средств.
- o При любых работах следить за сохранением надежного равновесия.
- o Никогда не наклоняться далеко за лестницы или парапеты.
- o Кроме того, всегда соблюдать соответствующие правила техники безопасности и охраны труда.



Запасные части

Указание!

Опасность повреждения вследствие использования ненадлежащих запасных частей. Использование ненадлежащих запасных частей может привести к утечкам

- или даже недостаточному водостоку со здания и, следовательно, к статической перегрузке.
- o Разрешается использовать только запасные части, одобренные производителем.

2.5 Требования к месту установки

Место установки должно отвечать следующим требованиям:

- o Место монтажа должно быть соответствующим образом ограждено.
- o Место установки должно быть чистым и сухим.
- o Проходные отверстия необходимо привести в соответствие с требованиями статики с помощью усилительных пластин.

2.6 Средства индивидуальной защиты

Всегда иметь наготове и носить указанное ниже защитное снаряжение.



Защитный шлем



Защитные перчатки



Страховочное приспособление



Защитная рабочая одежда



Средства защиты органов слуха



Защитные очки

RU



İçindekiler

1.	Bu kılavuz hakkında	16
1.1	Giriş	16
1.2	Aynen geçerli ek dokümanlar	16
2.	Güvenlik	16
2.1	Amacına uygun kullanım	16
2.2	Hatalı kullanım	16
2.3	Personel gereksinimi	16
2.4	Kalan riskler	16
2.5	Montaj yeri gereksinimi	16
2.6	Kişisel koruyucu donanım	16
3.	Montaj	17
3.1	SitaCompact yalıtım elemanı süzgeci	25
3.1.1	SitaCompact dikey	29
3.1.2	SitaCompact vidalı flanş	32
3.2	SitaCompact yandan çıkışlı	36
3.3	SitaCompact yükseltme elemanı	41
3.4	SitaCompact Fluid	46
3.5	SitaCompact Taşma Halkası	57
3.6	SitaCompact balkon başlığı	62
3.7	SitaCarport	67



1. Bu kılavuz hakkında

1.1 Giriş

Bu montaj talimatı düz çatı havalandırmasına yönelik yapı parçalarının montajına yönelik bir genel bakış sağlar.

1.2 Aynen geçerli ek dokümanlar

Çalışmalara başlamadan önce ilgili dokümanlara danışılmalı, o kunmalı ve dikkate alınmalıdır:

o İlgili tavan ve yalıtım membranı üreticisinin döşeme talimatı
o Yalıtım ve yapııştırıcı maddelerin güvenlik veri sayfaları

Ayrıca aşağıdaki standartlar ve yönetmelikler dikkate alınmalıdır:
DIN EN 12056-3, DIN 1986-3, DIN 1986-100, DIN 18531,
DIN 18234 , düz çatı yönetmeliği

2. Güvenlik

2.1 Amacına uygun kullanım

Düz çatı drenajı için boru sistemleri, sadece yağmur suyunu kullanan ve kullanılmayan düz çatılardan binanın ilgili drenaj sistemine iletmeye yarar.

- o Montaj yeri ile ilgili tüm gereksinimler sağlanmış olmalıdır.
- o Sadece montaj talimatında açıklandığı gibi monte edin.
- o Drenaj sistemini her zaman hesaplama kanıtına göre boyutlandırın.
- o Bağlanan boru hatlarını gerekirse uygun önlemler ile yağışma suyuna karşı koruyun.
- o Bitüm manşetleri için ayırma filmini kurutun.
- o Cıvatalı flanş yapılarındaki bitüm şeridini giriş kenarına yönlendirin ve doğrudan drenaj gövdesinin sabit flanşına kaynak yapın.

2.2 Hatalı kullanım



Uyarı!
Yanlış kullanımdan kaynaklanan tehlike!
Çatı çıkışının yanlış kullanımı sızıntılara neden olabilir Binanın yetersiz drenajı ve böylece statik aşırı yüklenmeye yol açar.

- o Üzerinde asla yetkisiz değişiklikler yapmayın.
Drenaj sistemi yapın.
- o Çatı süzgeci asla karşılık gelmeyen bir süzgeç olmadan kasayı betonlamayın.
- o Asla çatı çıkışının üzerine inşa etmeyin.
- o Bitümlü contalar için:
 - o asla sızdırmazlık manşonları kullanmayın.
 - o Drenaj gövdesinin sabit flanşını bitüm astar ile astarlayın.
- o Flanş bölgesindeki dikeyleri asla üst üste bindirmeyin
- o Polar destekli çatı kaplama membranlarını asla katlamayın.
- o Vidalı flanş yapılarındaki contaların çatı yalıtım malzemesi ile uyumluluğunu kontrol edin.

2.3 Personel gereksinimleri



Uyarı!
Yetersiz kalifikasyonda kaza tehlikesi
Yetersiz kalifiye kişiler tarafından yapılan çalışmalarda, kaza riski mevcuttur.
o Tüm faaliyetler sadece aşağıda belirtilen niteliklere sahip kişiler tarafından gerçekleştirilebilir.

Uzman kişi



Uzman kişi, eğitimi ve/veya uzun yıllara dayanan deneyimi nedeniyle montajı durumuna bağlı olarak usulüne uygun bir şekilde yapabilecek durumdadır. Ayrıca, çatı drenajı ve çatı su yalıtımına yönelik ilgili standartları ve yönetmelikleri bilir ve tehlikeleri ve montaj hatalarını kendi başına algılayabilecek ve önleyebilecek durumdadır.

2.4 Kalan riskler



Düşme

Uyarı!

- Yüksekte çalışma nedeniyle kaza tehlikesi. Çatılarda, platformlarda, merdivenlerde veya iskelelerde çalışırken dikkatsiz bir şekilde hareket edilmesi düşmeye neden olabilir.
- o Tüm yüksekte çalışmalarda her zaman koruyucu donanım kullanın.
 - o Her zaman uygun gereçlerle düşmeye karşı emniyete alın.
 - o Çalışırken güvenli duruşa dikkat edin.
 - o Hiçbir zaman merdivenlerin veya korkulukların üzerinden fazla sarkmayın.
 - o Ayrıca ilgili kaza önleme direktiflerini dikkate alın.

Yedek parçalar

Bilgi!

- Yanlış yedek parçalar nedeniyle hasar tehlikesi.**
Yanlış yedek parça kullanımı sızıntılardan başlayarak binanın yetersiz drenajına ve böylece statik yüklenmeye neden olabilir.
- o Sadece üretici tarafından onaylanan yedek parçaları kullanın.



2.5 Montaj yerine yönelik gereksinimler

- Montaj yeri aşağıdaki gereksinimleri karşılamalıdır:
- o Montaj yeri yeterince kordon altına alınmalıdır.
 - o Montaj yeri temiz ve kuru olmalıdır.
 - o Yayılmaları takviye sacları ile statik gereksinimlere uyarlayın.

2.6 Kişisel koruyucu donanım

Aşağıda listelenen koruyucu donanımı her zaman hazırda bulundurun ve kullanın.



Baret



Koruyucu eldivenler



Düşme emniyeti



Koruyucu iş giysisi



İşitme koruması



Koruyucu gözlük



DE	3. Montage
EN	3. Assembly
FR	3. Montaj
NL	3. Bevestiging
PL	3. Montaż
RU	3. Монтаж
TR	3. Montaj



	DE	EN	FR	NL	PL	RU	TR
	Entsorgen	Disposal	Mettre au rebut	Afvoeren	Utylizacja	Утилизация	Atık
	Arbeit prüfen	Check work	Vérifier le travail effectué	Werkzaamheden controleren	Kontrola pracy	Проверка работы	İşin kontrol edilmesi
	Warten	Wait	Entretien	Onderhoud	Konserwacja	Техобслуживание	Bekleyin
	Reinigen	Cleaning	Nettoyer	Reinigen	Czyszczenie	Очистка	Temizleyin
	Schleifen	Grinding	Poncer	Schuren	Szlifowanie	Шлифование	Taşlama
	Festziehen über Kreuz	Tighten crosswise	Serrage en croix	Draai kruiselings vast	Dokręć na krzyż	Затяните крест-накрест	Çapraz sıkın
	Optionale Handlung	Optional action	Action supplémentaire	Bijkomende werken	Działanie opcjonalne	Опциональное действие	isteğe bağlı işlem
	optionales Zubehör	Optional accessories	Accessoires facultatives	Optionele accessoires	Akcesoria opcjonalne	Дополнительные принадлежности	isteğe bağlı aksesuar
	Vorbemerkungen beachten	Observe preliminary remarks	Observer les remarques préliminaires	Voorafgaande opmerkingen	Przestrzegać uwag wstępnych	Соблюдайте предварительные замечания	Ön açıklamaları dikkate alın





	DE	EN	FR	NL	PL	RU	TR
	Hammer	Hammer	Marteau	Hamer	Młotek	Молоток	Çekiç
	Locheisen	Hole punch	Poinçon	Ponstang	Przebijak	Пробой-ник	Delgi
	Messer	Blade	Couteau	Cuttermes	Nóż	Нож	Bıçak / Falçata
	Säge	Saw	Scie	Zaag	Piła	Пила	Testere
	Stift	Pen	Crayon	Potlood	Kołek	Карандаш	Kalem
	Zollstock	Folding rule	Mètre pliant	Vouw-meter	Miara	Складной метр	Katlanır metre
	Akku-schrauber	Cordless drill	Visseuse sans fil	Accu-schroeven-draaier	Wkrętak akumulato-rowy	Шуруповёрт	Şarjlı tornavida
	Feile	File	Lime	Vijl	Pilnik	Напиль-ник	Eğe
	Klebstoff	Adhesive	Colle	Lijm	Klej	Клей	Yapıştırıcı

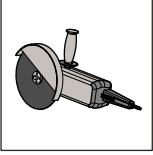
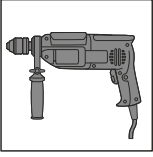

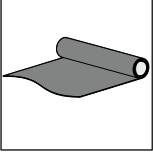
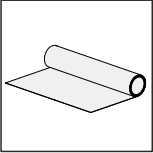
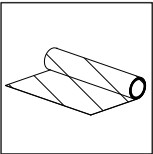
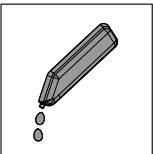
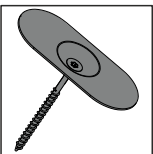

	DE	EN	FR	NL	PL	RU	TR
	PUR-Schaum	PUR foam	Mousse polyuréthane	PUR-schuim	Pianka PUR	Монтажная пена	PUR köpük
	Innen-sechskant	Hex key	Clé Allen	Inbus-sleutel	Gniazdo sześciokątne	Ключ шестигранный	İçten altıgen
	Wasserwaage	Spirit level	Niveau à bulle	Waterpas	Poziomica	Водяной уровень	Su terazisi
	Drehmoment-schlüssel	Torque wrench	Clé dynamométrique	Moment-sleutel	Klucz dynamometryczny	Динамометрический ключ	Tork anahtarı
	Winkelschleifer	Angle grinder	Meuleuse d'angle	Haakse slijpmachine	Szlifierka kątowa	Углошлифовальная машина	Açılı taşlama
	Bohrmaschine	Power drill	Foreuse	Boormachine	Wiertarka	Электродрель	Matkap
	Bohrer	Drill	Foret	Boor	Wiertło	Сверло	Burgu
	Bohrkronen	Cutter	Trépan	Boorkop	Koronka wiertarska	Буровая коронка	Matkap ucu
	Farbrolle	Paint roller	Rouleau de peinture	Verfroller	Rolka farbowa	Валик для краски	Boya rulosu

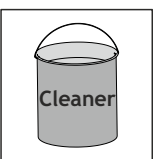
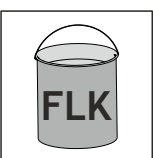

	DE	EN	FR	NL	PL	RU	TR
	Schere	Scissors	Ciseaux	Schaar	Nożyce	Ножницы	Makas
	Dachbahn	Roof membrane	Membrane de toit	Dakbaan	Membrana dachowa	Гидро-изоляция	Çatı örtüsü
	Vlies	Fleece	Molleton	Vlies	Flizelina	Геоткань	Keçe örtüsü
	Trenn-/Schutzlage	Separating/protective layer	Couche de séparation/protection	Scheidings-/beschermingslaag	Warstwa rozdzielająca/ochronna	Разделительный/защитный слой	Ayırma/koruyucu tabaka
	Gleitmittel	Lubricant	Lubrifiant	Glijmiddel	Środek smarny	Смазка	Kaydırıcı madde
	Tellerbefestiger	Screw rosettes	Rosaces à vis	Schroef rozet	Talerz mocujący	Крепёж тарельчатый	Raptet
	Schraube	screw	Vis	Schroef	Śruba	Шуруп	vida
	Reiniger	Cleaner	Nettoyant	Reiniger	Środek do czyszczenia	Очиститель	Temizleyici
	Flüssig-kunststoff	Liquid applied waterproofing	Liquide synthétique	Vloeibaar kunststof	Płynne tworzywo sztuczne	Жидкий полимер	likit membran

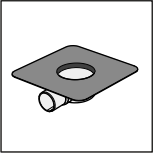
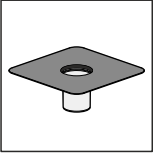

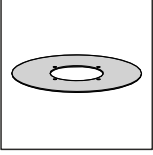
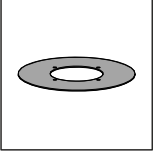
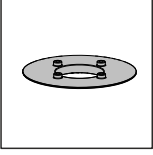
	DE	EN	FR	NL	PL	RU	TR
	Gully	Outlet	Avaloir	Dakkolk	Wpust dachowy	Воронка	Süzgeç
	Gully, abgewinkelt	Outlet, angled	Avaloir, sortie coudée	Dakkolk, gebogen	Wpust dachowy, skośny	Воронка, угловая	Süzgeç, yandan çıkışlı
	Aufstockelement	Extension Unit	Rehausse	Verhogings-element	Element nadbudowy	Надставной элемент	Yükseltme elemanı
	Dichtring	Sealing ring	Bague d'étanchéité	Dichtingsring	Pierścień uszczelniający	Уплотнительное кольцо	Conta halkası
	PUR Grundkörper	PUR base body	Corps en PUR	PUR-basis-element	Korpus z PUR	Корпус из полиуретана	PUR ana gövde
	Gewindestift	Grub screw	Vis sans tête	Stelschroef	Śruba z łbem walcowym	Резьбовая шпилька	yivli çubuk
	große Dichtung	Large seal	Grand joint	Grote afdichting	duża uszczelka	Манжет уплотнительный, большой	büyük conta
	kleine Dichtung	Small seal	Petit joint	Kleine afdichting	mała uszczelka	Манжет уплотнительный, малый	küçük conta
	Losflansch	Loose flange	Bride libre	Losse flens	Koźnierz zaciskowy	Прижимной фланец	Flanş



	DE	EN	FR	NL	PL	RU	TR
	Unterlegscheibe	Washer	Rondelle	Rondel	Podkładka	Подкладная шайба	Rondela
	Mutter	Nut	Écrou	Moer	Nakrętka	Гайка	Somun
	Kiesfang	Dome grate	Arrêt de gravier	Bladvanger	Koszyk żwirowy	Листоуловитель	Çakıl tutucu
	Aufsatz	Grating	Couronnement	Opzetstuk	Nasadka	Насадка	Başlık
	Schutzdeckel	Protection cover	Couvercle protecteur	Beschermkap	Kołpak	Защитная крышка	Koruma kapağı
	Flachrost	Flat grate	Grille plate	Vlak rooster	Kratka płaska	Плоская решетка	Düz ızgara
	Höhenausgleichsstück	Height compensation piece	Bague de réglage en hauteur	Hoogtecompensatiestuk	Element nadbudowy nasadki	Элемент выравнивания высоты	Yükseklik dengeleme parçası
	Rohraufnahme	Pipe holder	Support tuyau	Buissteun	Adapter na rurę	Опора для крепления трубы	Boru adaptörü
	Rohr	Pipe	Tuyau	Buis	Rura	Труба	Boru



	DE	EN	FR	NL	PL	RU	TR
	Fassaden-Abdeckplatte	Cladding cover plate	Plaque de recouvrement de façade	Gevelafdekplaat	Płyta ochronna	Фасадная пластина	Sephe kapak plakası
	Sicherungsschelle	Safety clamp	Collier de serrage	Buisklem	Obejma zaciskowa	Фиксаторный хомут	Emniyet kelepçesi
	Anstauring	Retaining ring	Trop-plein	Overloop	Pierścień spiętrzający	Подпорное кольцо	Taşma Halkası
	Endrost	End grate	Grille finale	Eindrooster	Kratka końcowa	Торцевая решетка	Uç izgarası
	Aufsatzgehäuse	Attachment housing	Boîtier en saillie	Bevestiging huisvesting	Obudowa mocująca	Приставной корпус	Eklenti muhafazası
	Gittereinlasssieb	Grid inlet sieve	Tamis d'entrée en grille	Roosterinlaatzeef	Sito wlotowe z siatką	Решетчатое входное сито	Izgara giriş eleği
	Höhenausgleichsstück	Height compensation piece	Bague de réglage en hauteur	Hoogtecompensatiestuk	Element nadbudowy nasadki	Элемент выравнивания высоты	Yükseklik dengeleme parçası
	Aufsatz mit Endrost	Grating with end grate	Couronnement avec grille finale	Opzetstuk met eindrooster	Nasadka z kratka końcowa	Насадка с торцевой решеткой	Başlık ile uç izgarası
	Verblendkappe	Facing cap	Cache de parement	Afdekkap	Maskownica	Облицовочная крышка	Kaplama başlığı



DE	3.1 SitaCompact Dämmkörper Gully
EN	3.1 SitaCompact insulating body outlet
FR	3.1 SitaCompact pièce d'isolation pour avaloir
NL	3.1 SitaCompact isolatieblok dakkolck
PL	3.1 SitaCompact korpus izolacyjny
RU	3.1 Изоляционная плита SitaCompact для воронки
TR	3.1 SitaCompact yalıtım elemanı süzgeci

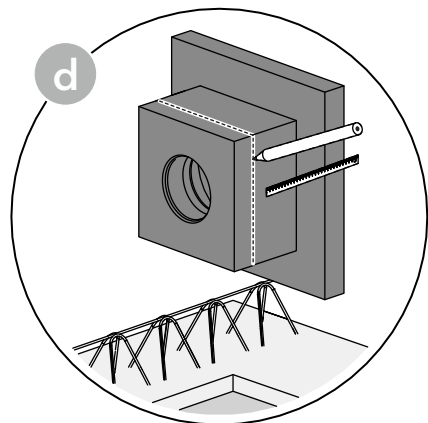
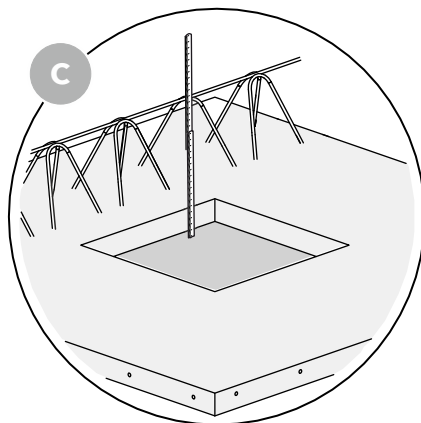
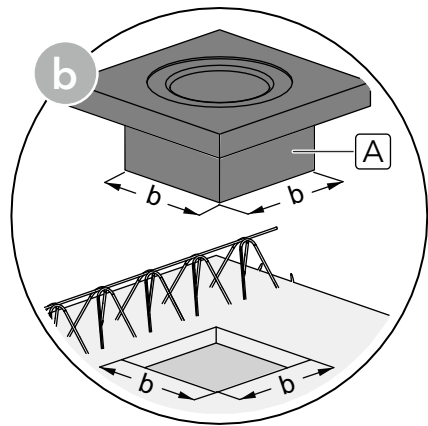
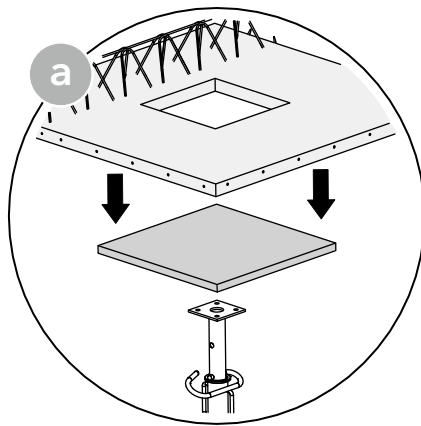
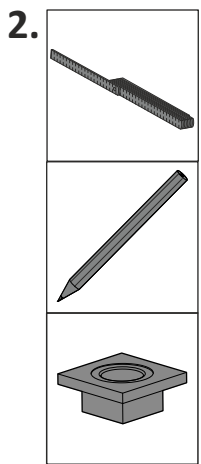
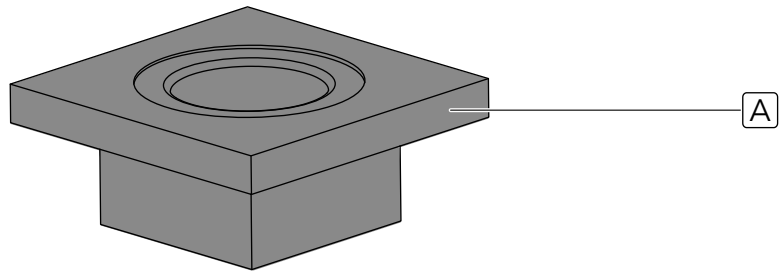
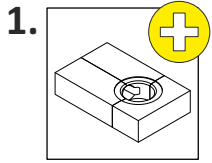

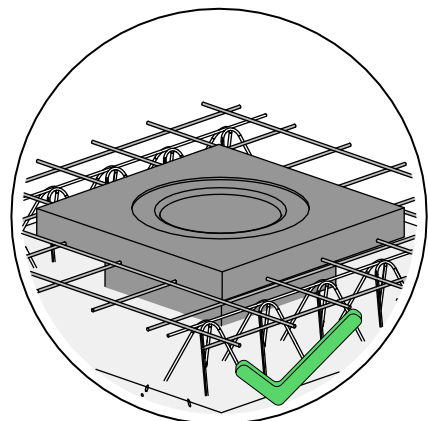
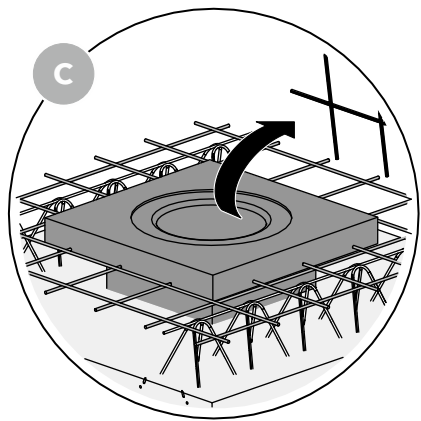
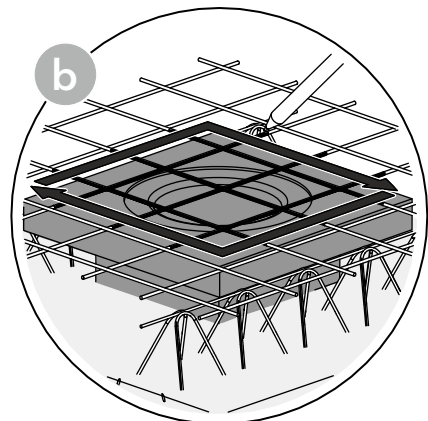
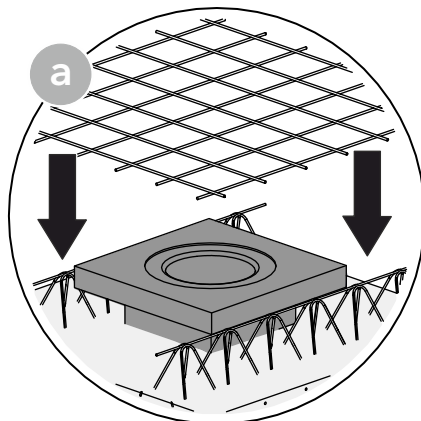
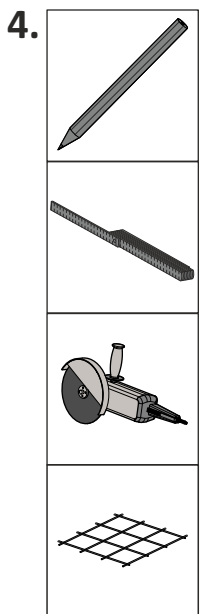
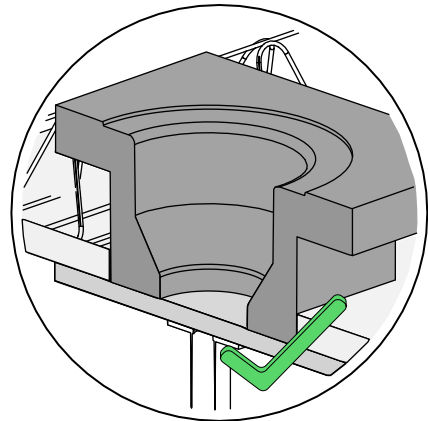
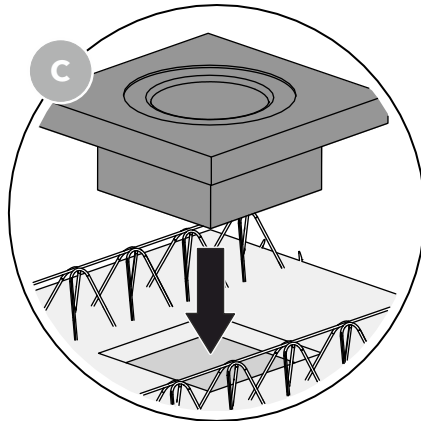
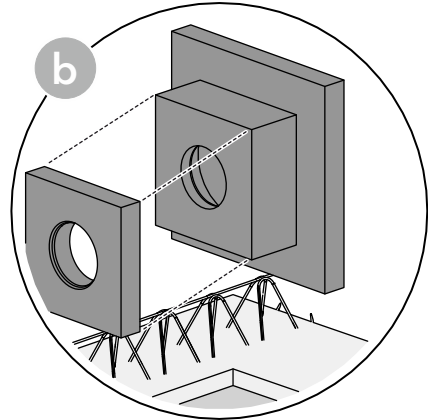
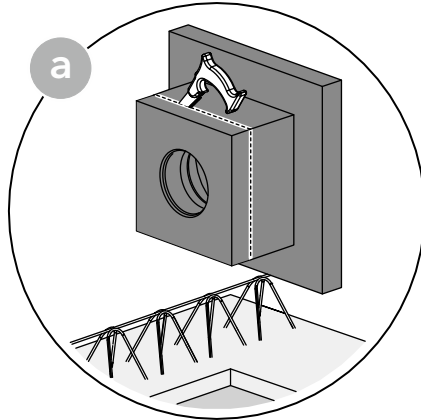
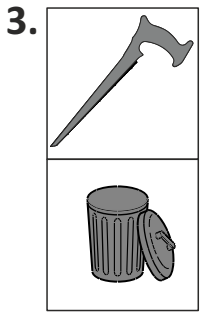

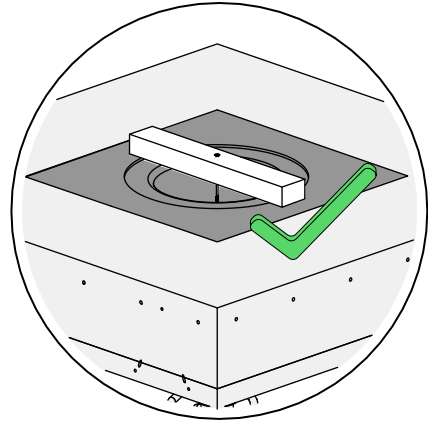
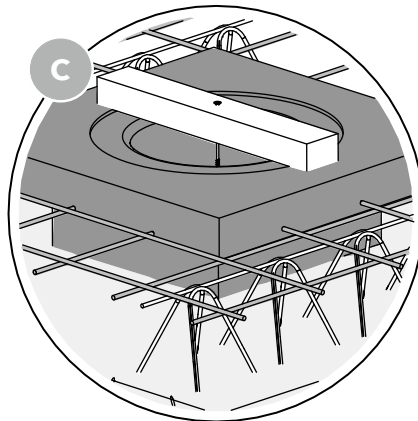
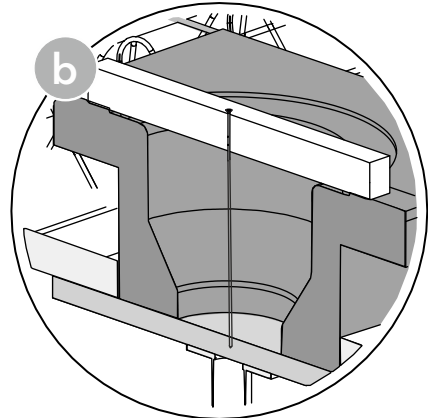
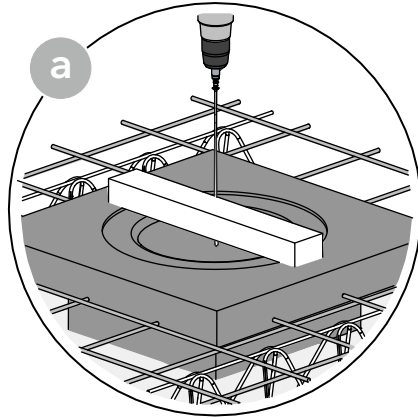
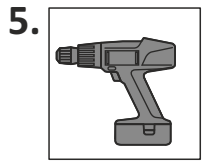



DE	3.1.1 SitaCompact senkrecht
EN	3.1.1 SitaCompact vertical
FR	3.1.1 SitaCompact sortie verticale
NL	3.1.1 SitaCompact verticaal
PL	3.1.1 SitaCompact pionowy
RU	3.1.1 SitaCompact вертикальная
TR	3.1.1 SitaCompact dikey



1.

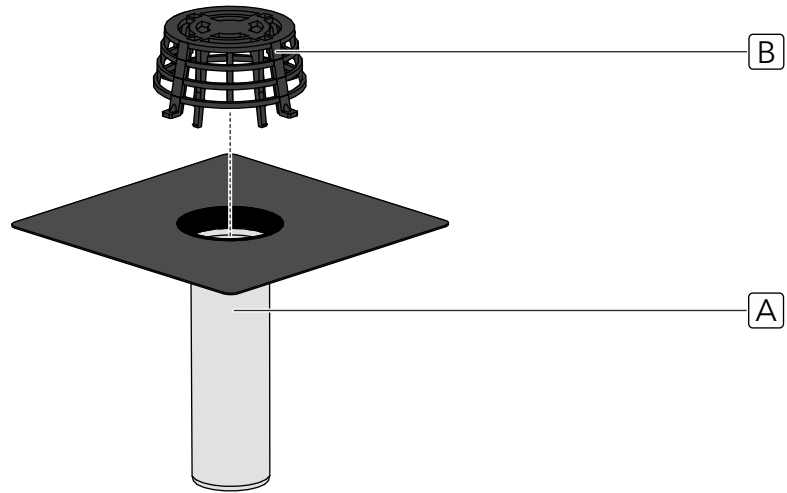

2.

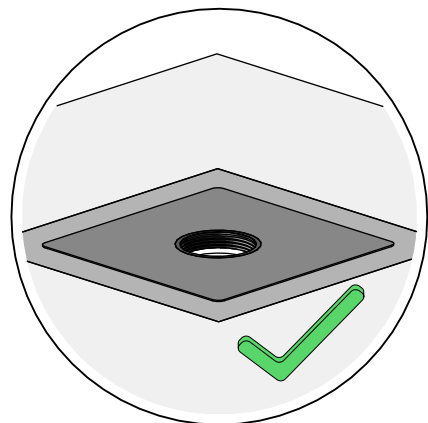
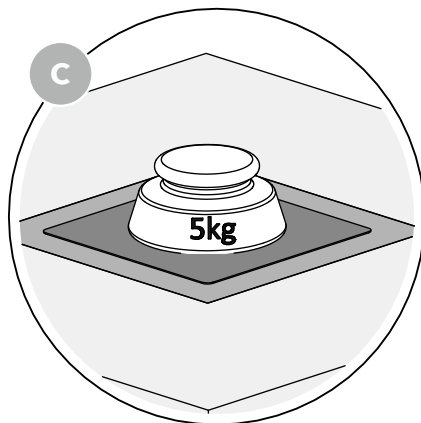
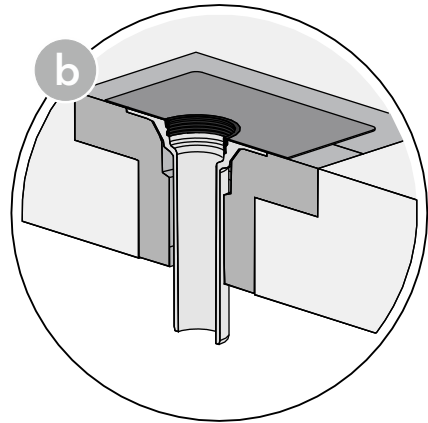
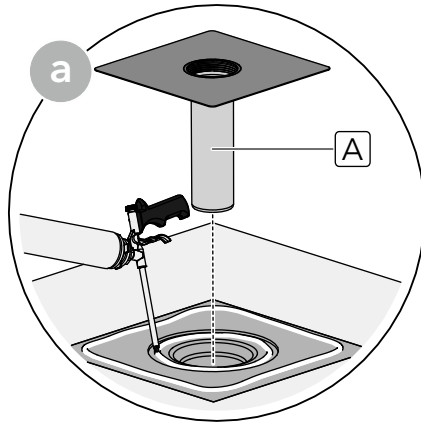
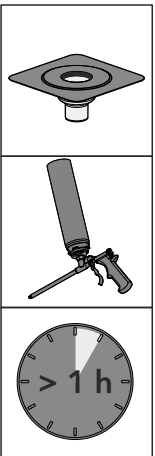

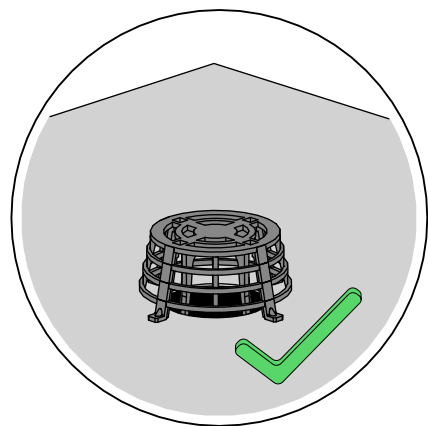
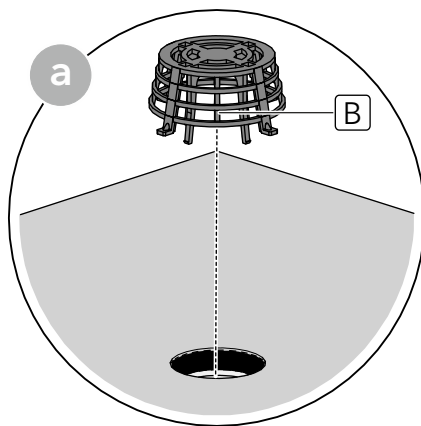
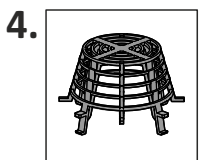
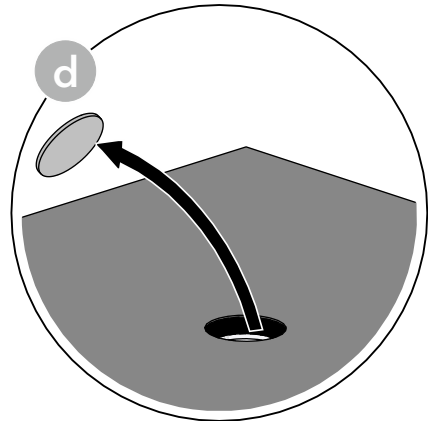
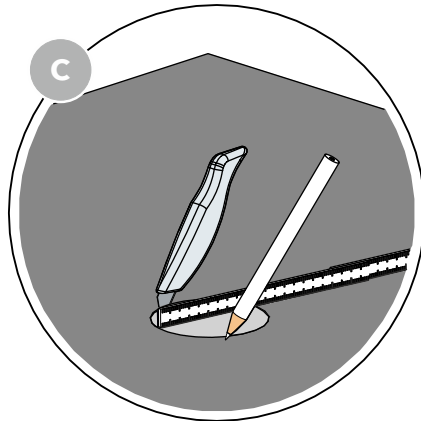
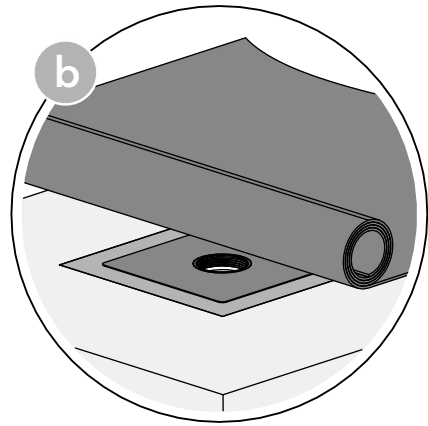
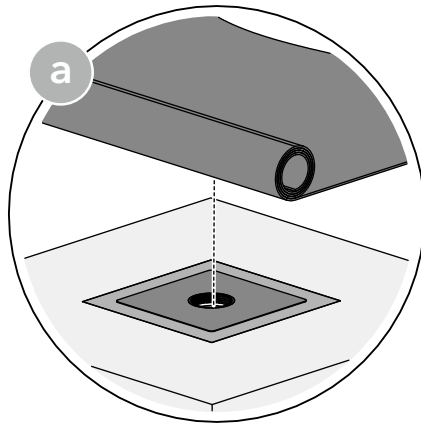
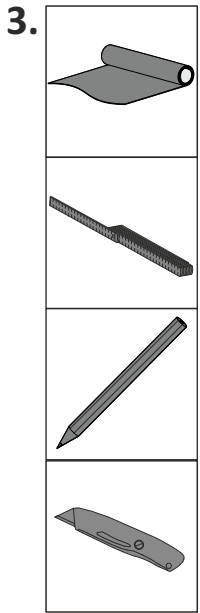



DE	3.1.2 SitaCompact Schraubflansch
EN	3.1.2 SitaCompact screw-on flange
FR	3.1.2 SitaCompact Bride à visser
NL	3.1.2 SitaCompact met schroefflens
PL	3.1.2 SitaCompact kołnierz zaciskowy
RU	3.1.2 SitaCompact с фланцем
TR	3.1.2 SitaCompact vidalı flanş



1.

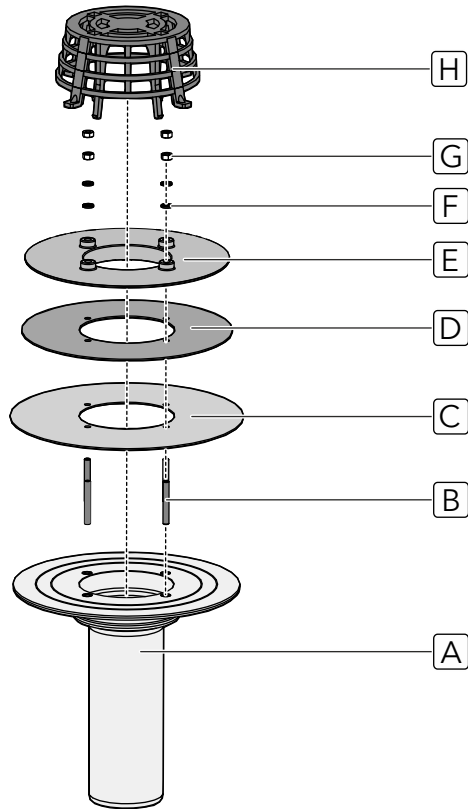

2.

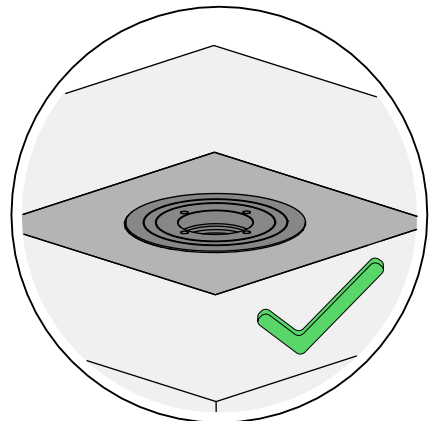
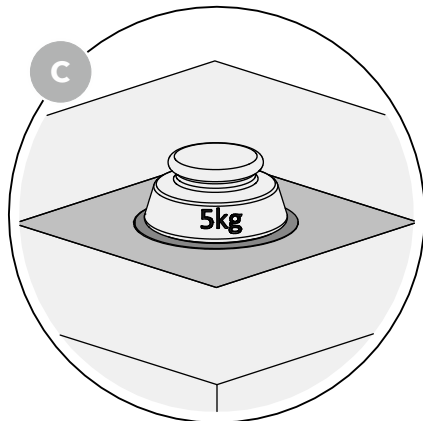
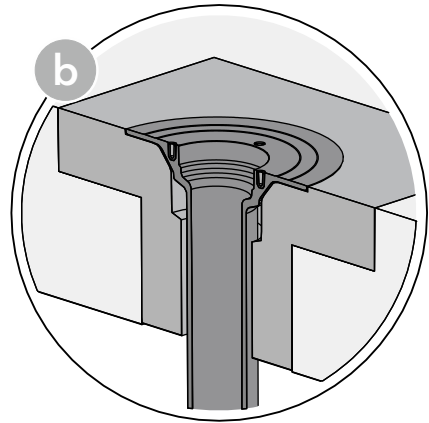
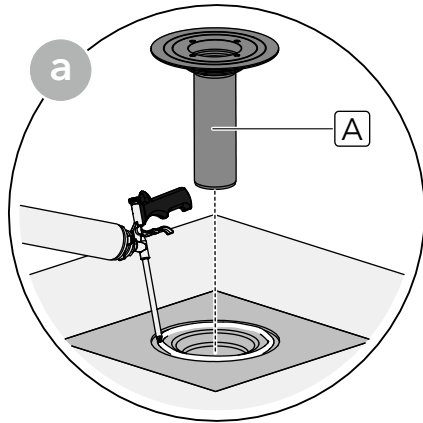
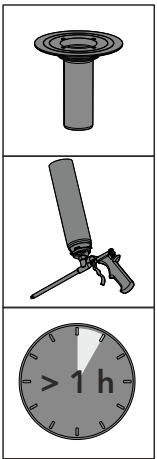

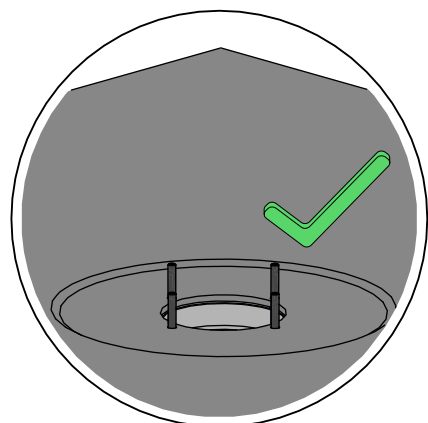
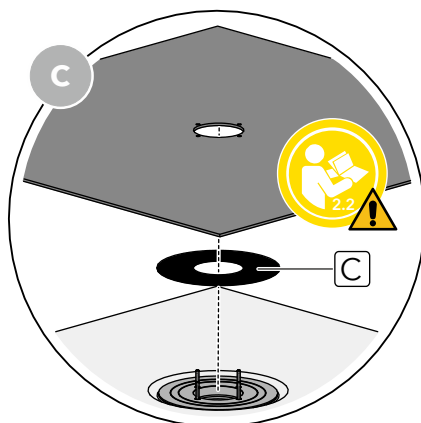
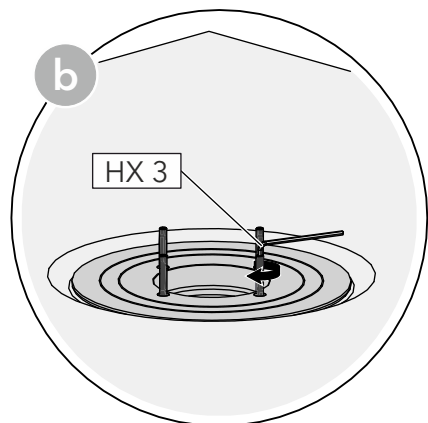
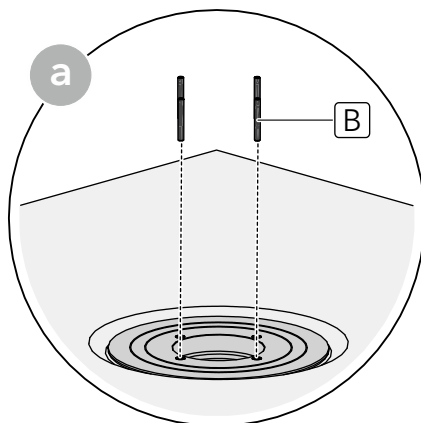
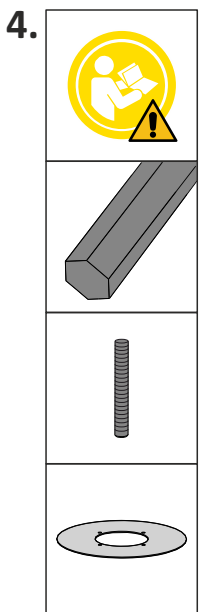
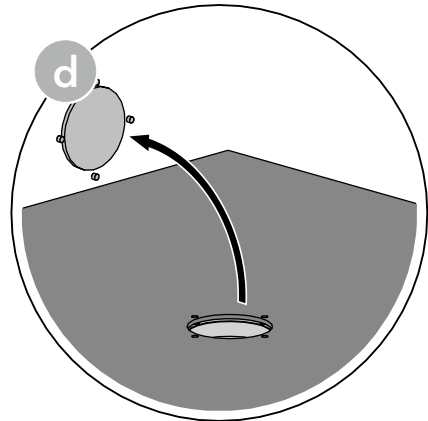
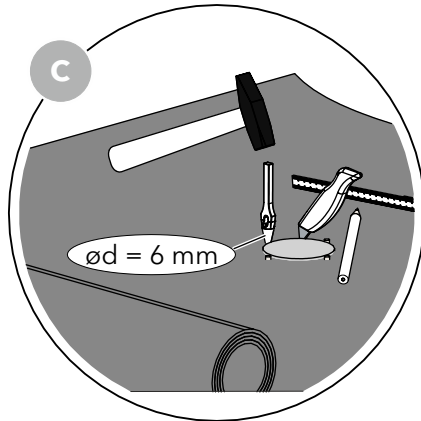
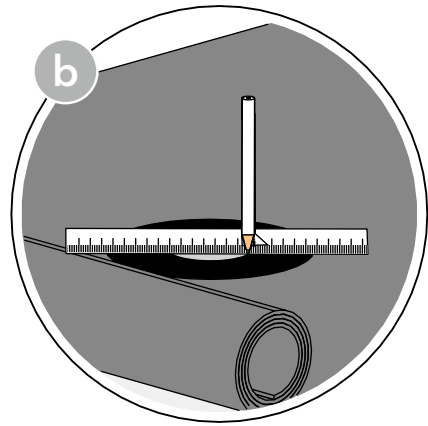
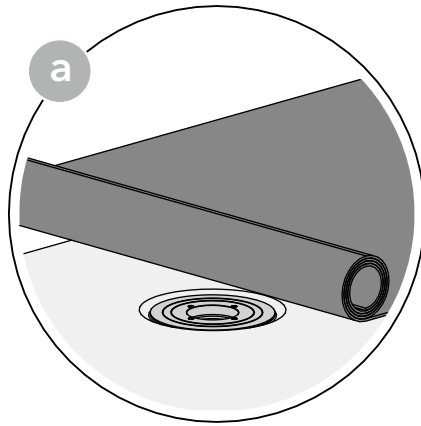
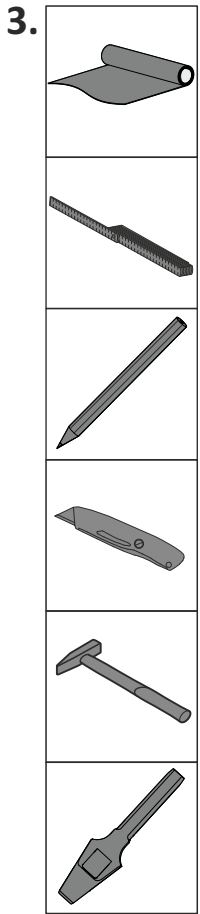

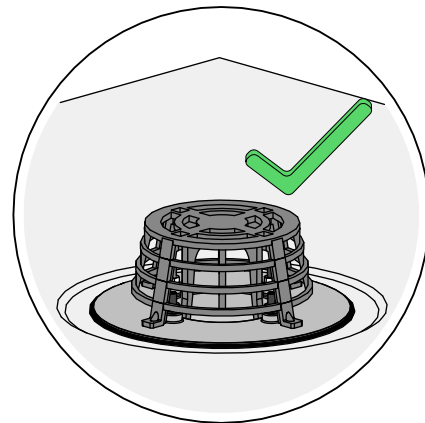
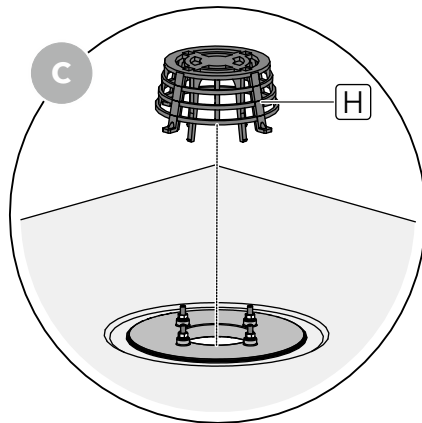
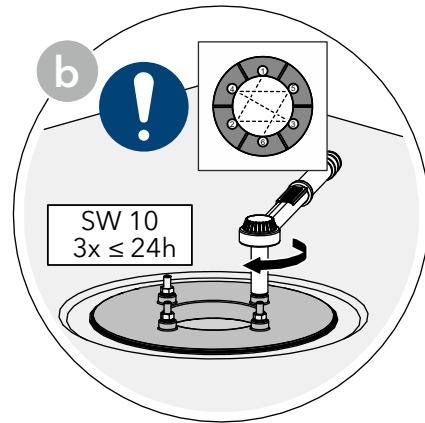
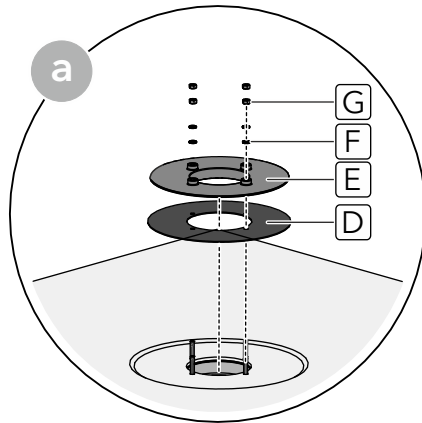
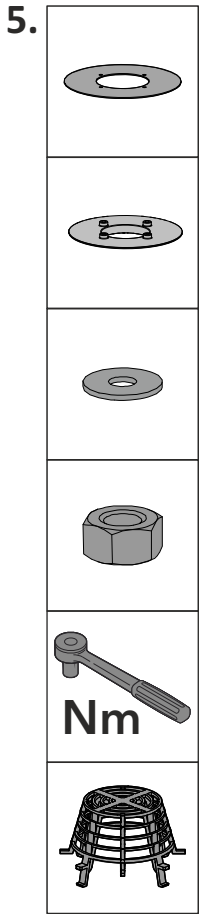

DE	Anziehmomente		
	Bitumen mit Glasgewebe	Bitumen mit anderen Einlagen	Kunststoff- & Elastomerbahnen
EN	Torques		
	Bitumen with glass fabric	Bitumen with other inlays	Plastic and elastomer sheets
FR	Couples de serrage		
	Bitumes avec tissu de verre	Bitumes avec autres inserts	Lés plastiques & élastomères
NL	Aanhaalmomenten		
	Bitumen met glasweefsel	Bitumen met andere voeringen	Kunststof- & elastomeerbanen
PL	Momenty dokręcania		
	Bitum z tkaniną szklaną	Bitum z inną osnową	Membrany z tworzyw sztucznych i elastomerów
RU	Моменты затяжки		
	Битумы со стеклотканью	Битумы с другими усиливающими слоями	Пластиковое и эластомерное кровельное полотно
TR	Sıkma torkları		
	Cam dokulu bitüm	Diğer tipte tabanlı bitüm	Plastik ve elastomerik membranlar
	8 Nm	8 Nm	8 Nm



DE	3.2 SitaCompact abgewinkelt
EN	3.2 SitaCompact angled
FR	3.2 SitaCompact sortie coudée
NL	3.2 SitaCompact gebogen
PL	3.2 SitaCompact skośny
RU	3.2 SitaCompact угловая
TR	3.2 SitaCompact yandan çıkışlı



1.

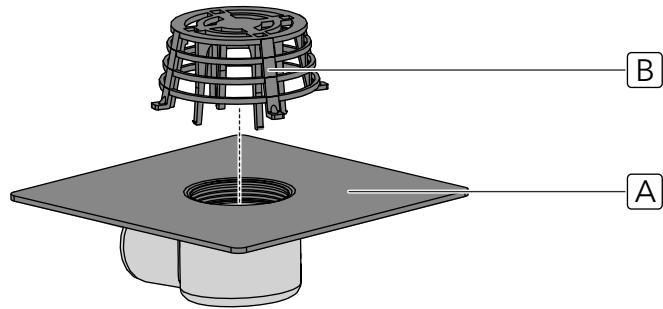

2.

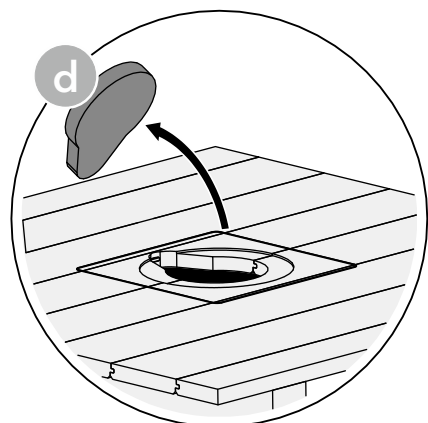
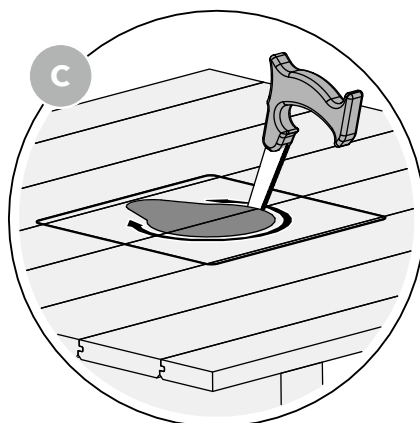
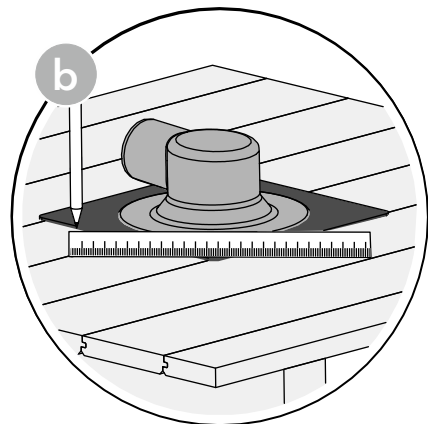
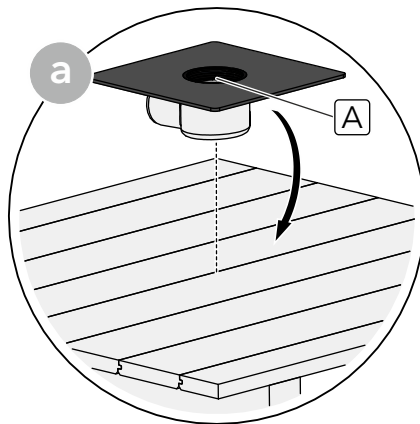
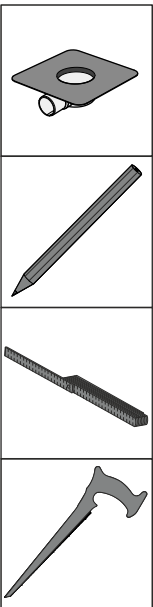

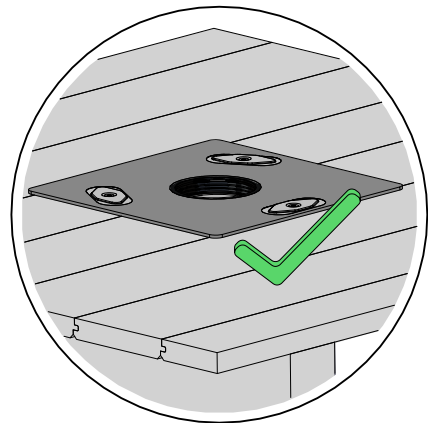
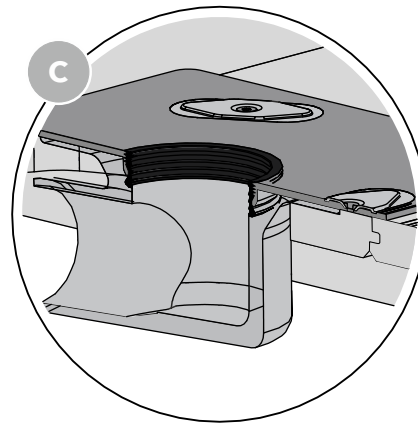
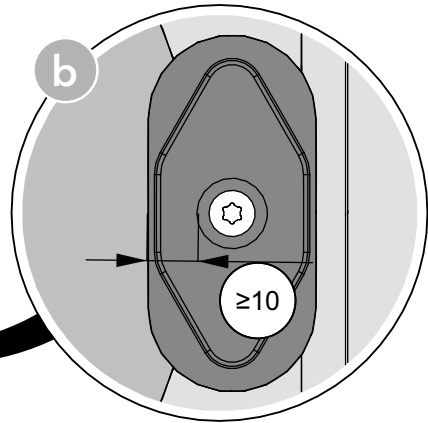
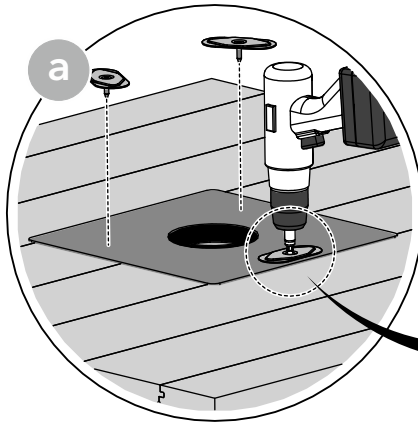
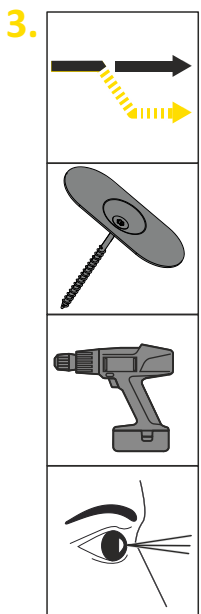
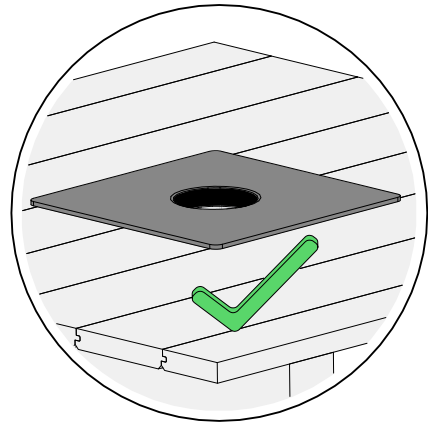
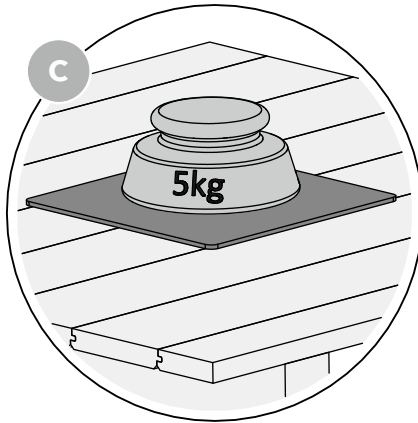
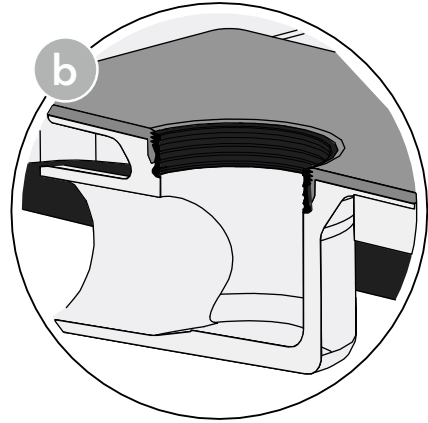
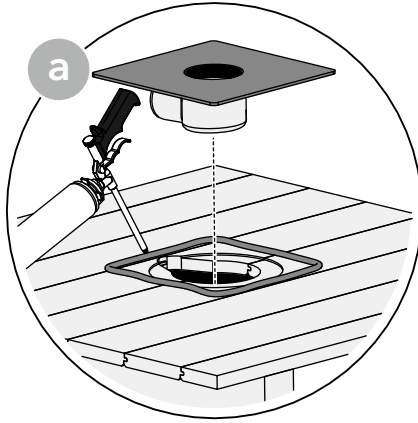
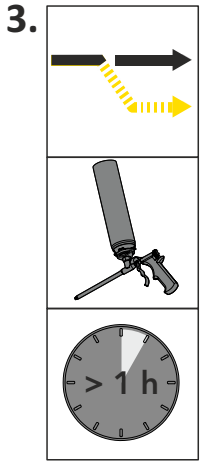

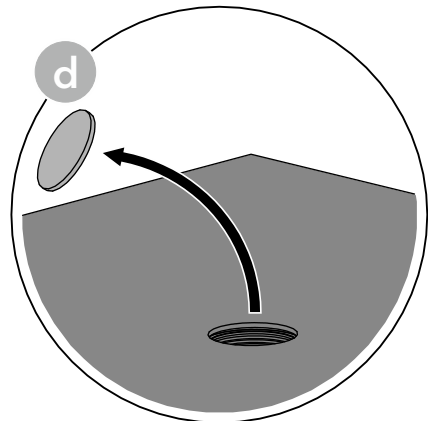
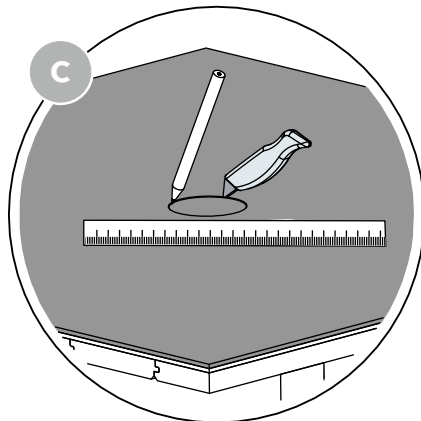
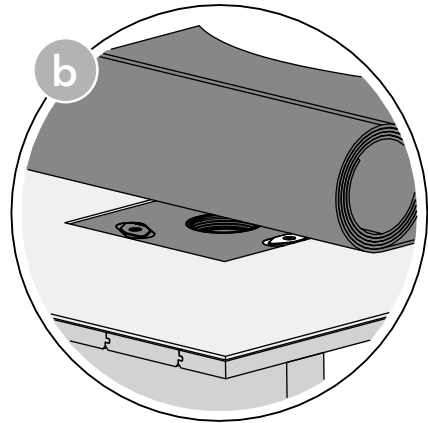
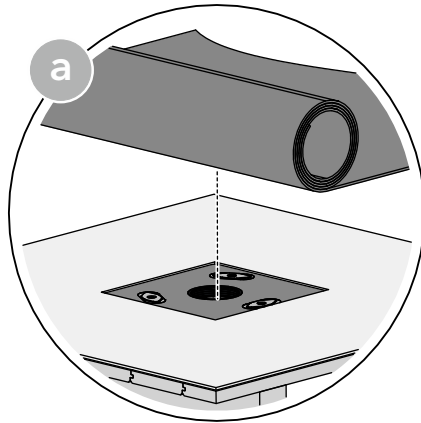
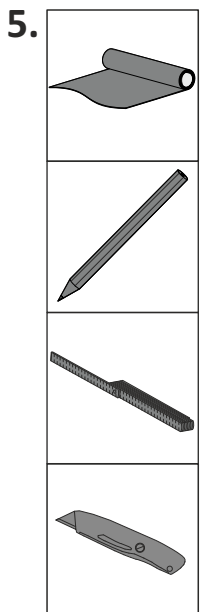
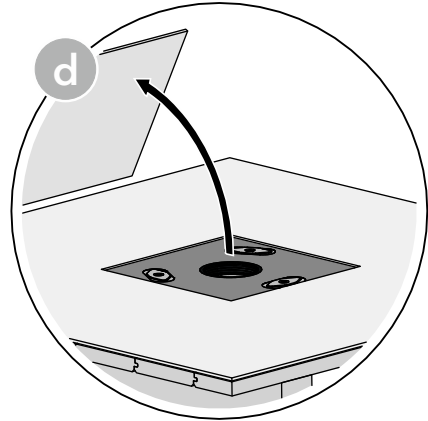
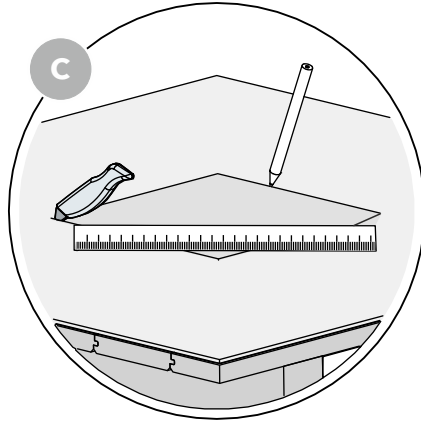
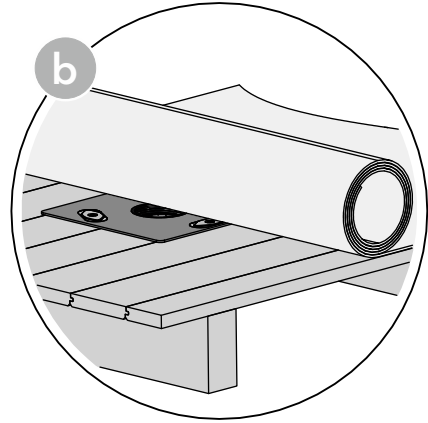
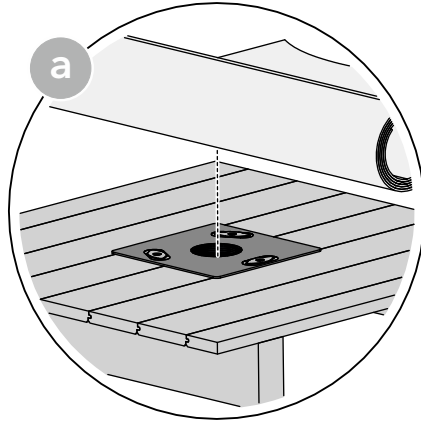
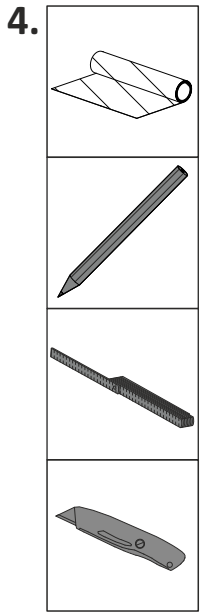

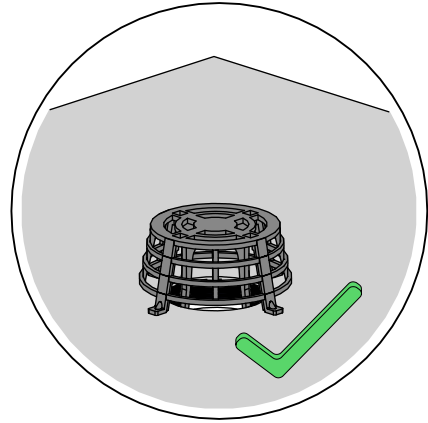
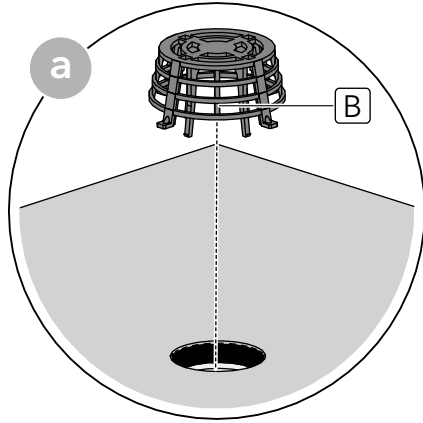
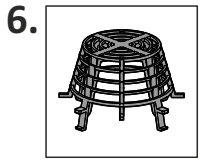



DE	3.3 SitaCompact Aufstockelement
EN	3.3 SitaCompact extension element
FR	3.3 SitaCompact rehausse
NL	3.3 SitaCompact verhogingselement
PL	3.3 SitaCompact element nadbudowy
RU	3.3 Надставной элемент SitaCompact
TR	3.3 SitaCompact yükseltme elemanı

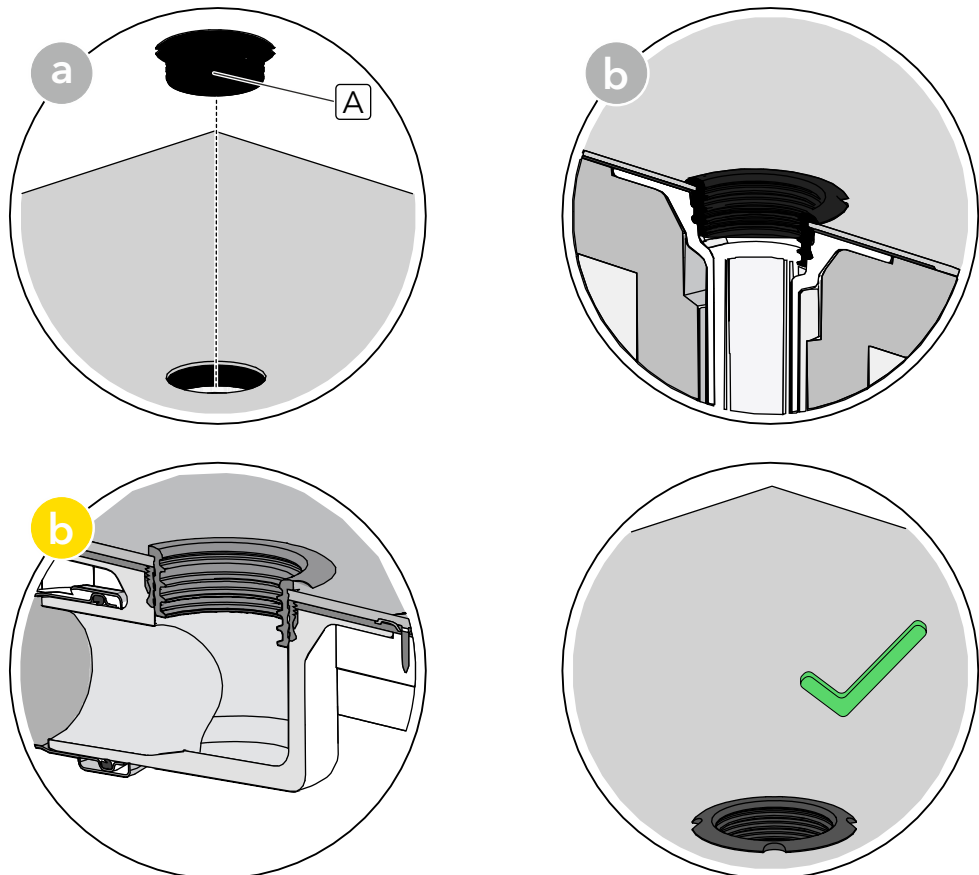
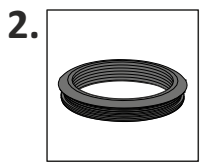
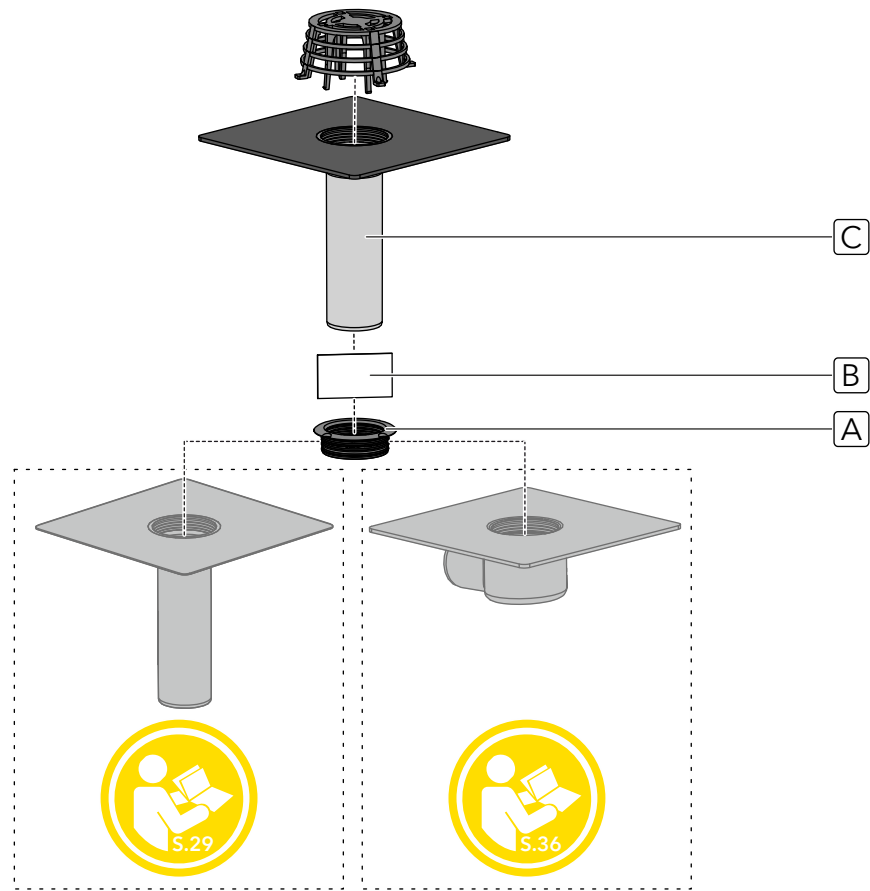
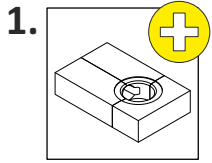

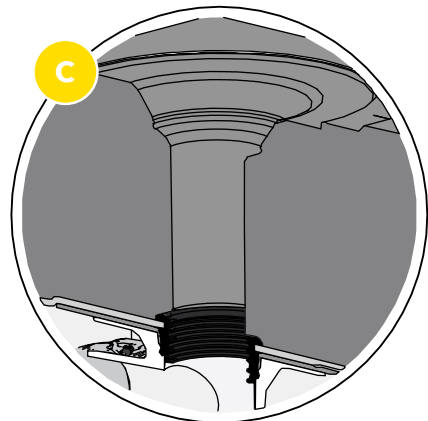
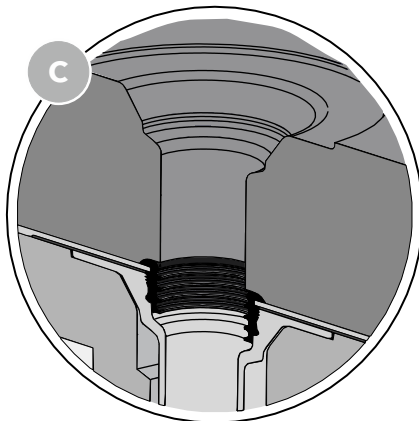
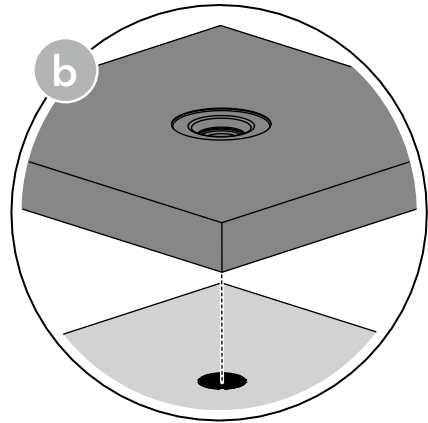
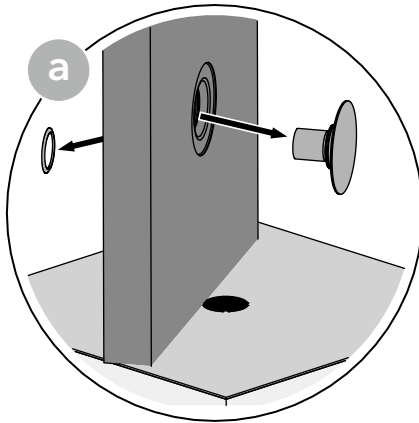
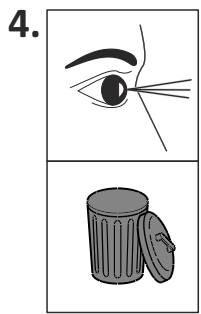
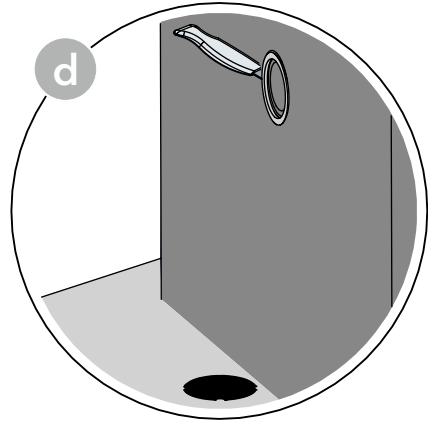
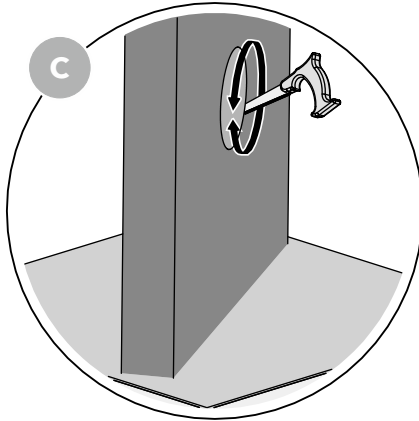
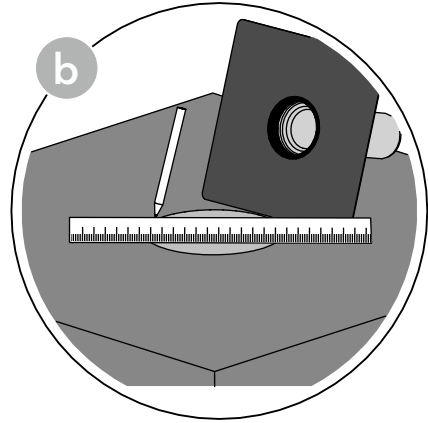
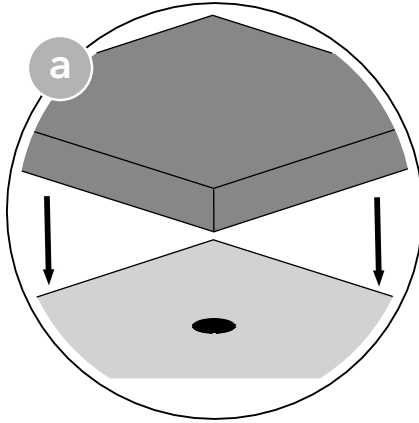
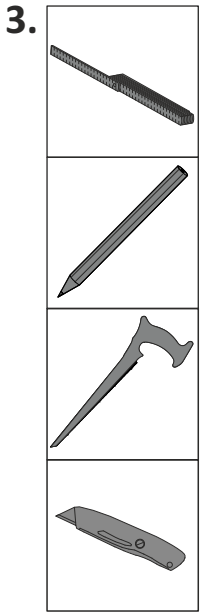

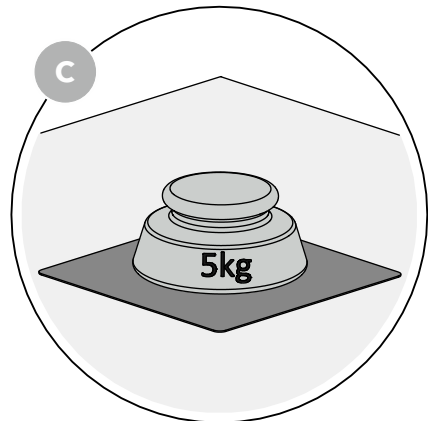
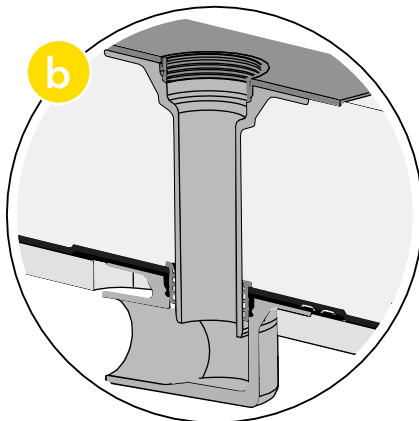
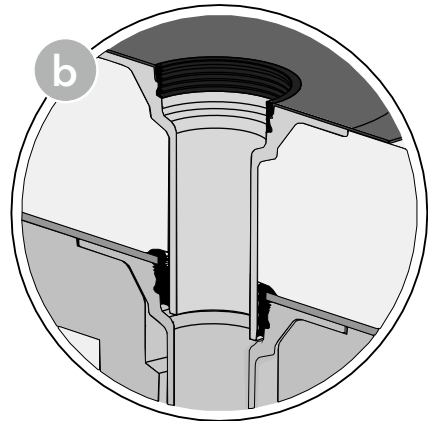
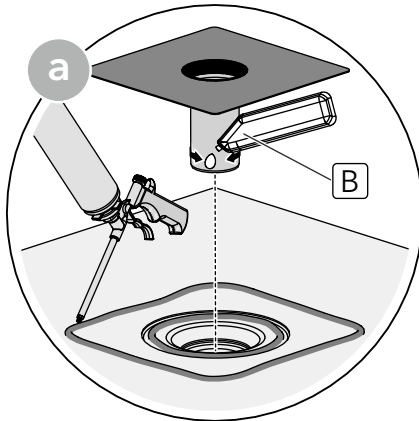
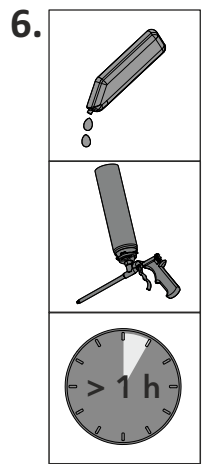
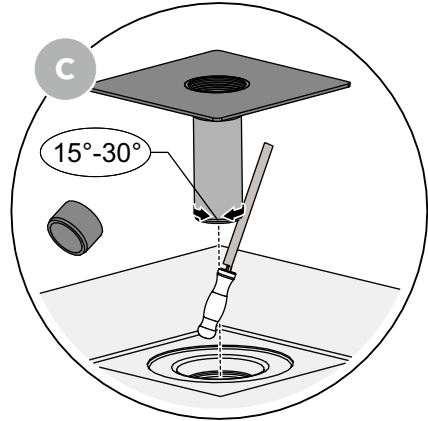
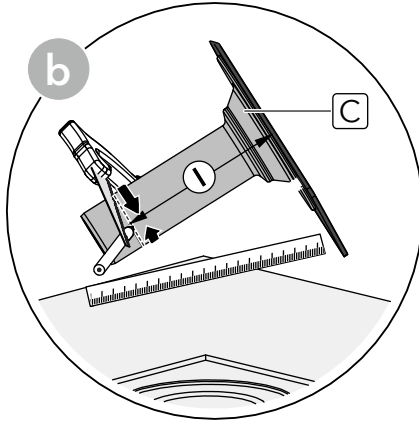
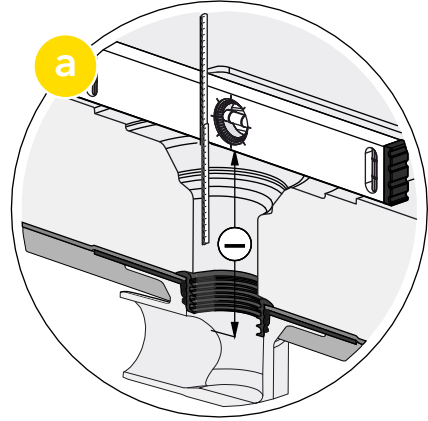
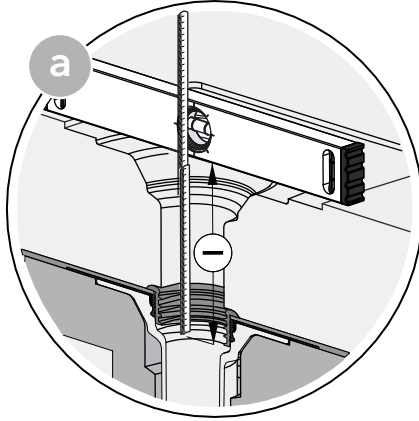
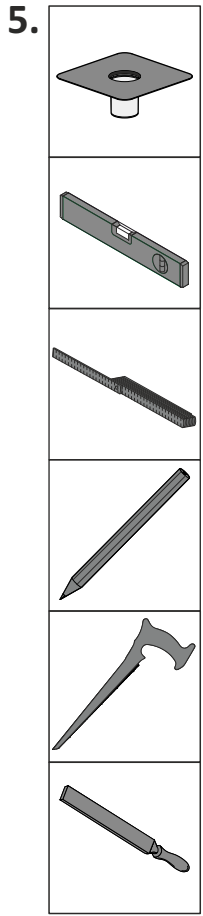

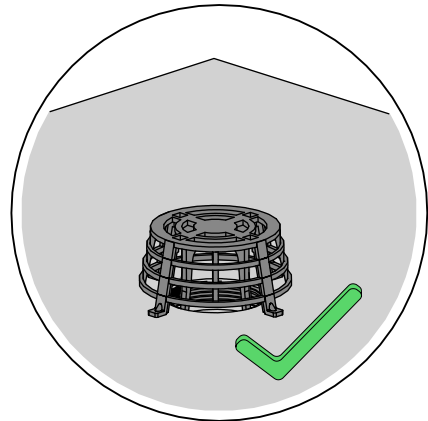
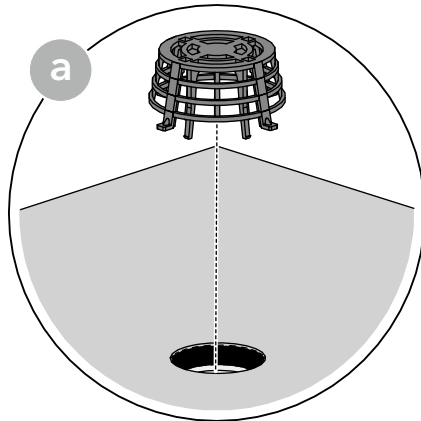
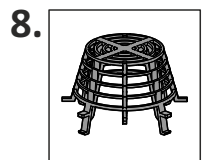
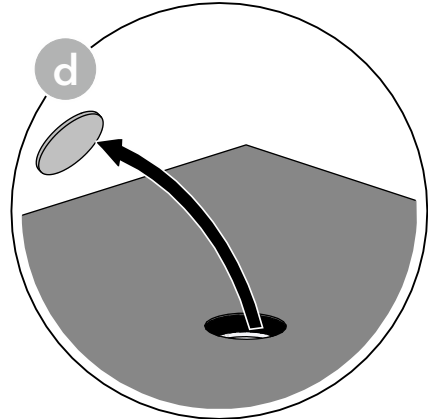
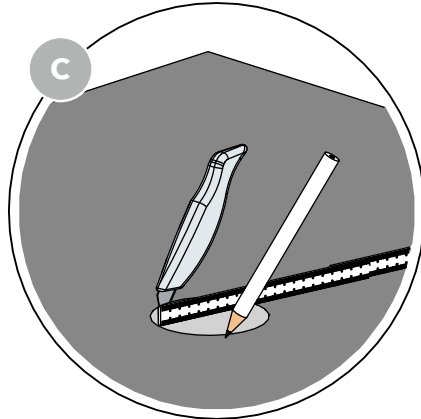
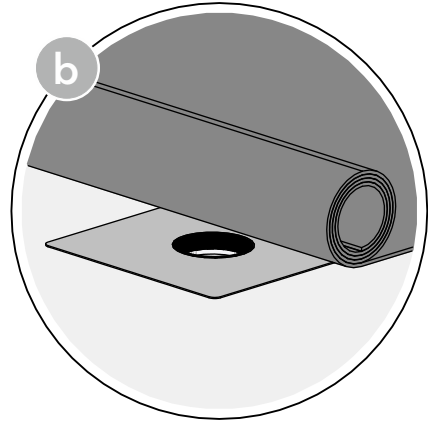
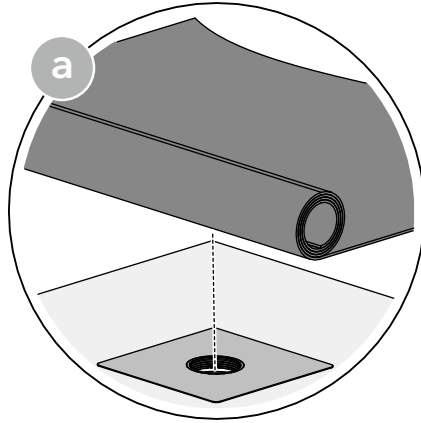
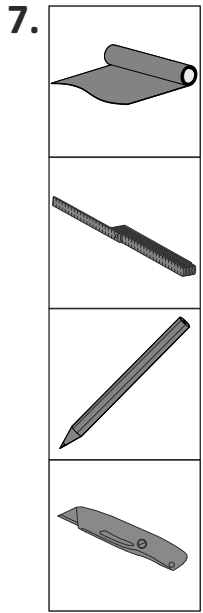



DE	3.4 SitaCompact Fluid
EN	3.4 SitaCompact Fluid
FR	3.4 SitaCompact Fluid
NL	3.4 SitaCompact Fluid
PL	3.4 SitaCompact Fluid
RU	3.4 SitaCompact Fluid
TR	3.4 SitaCompact Fluid



1.

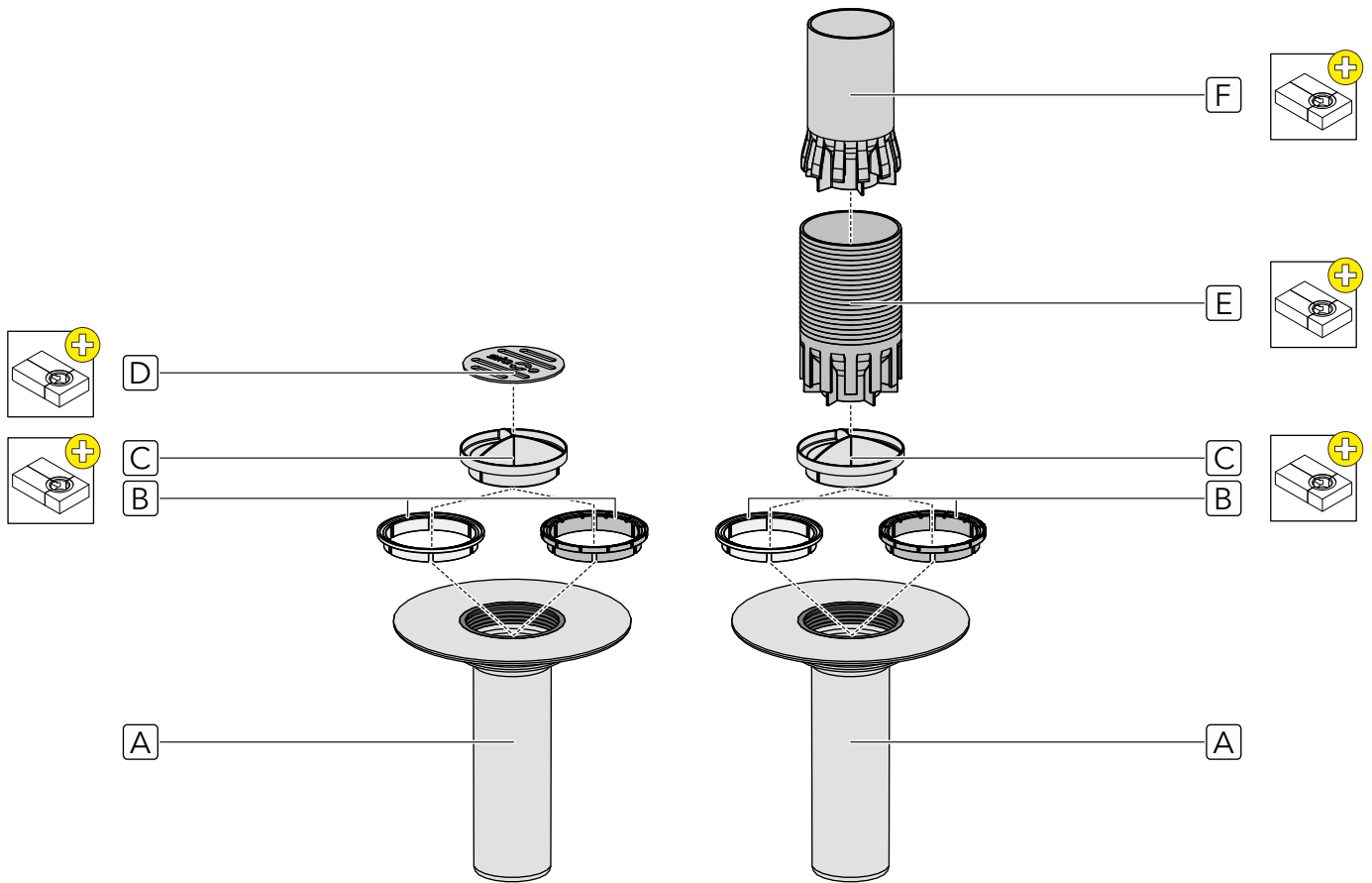

2.

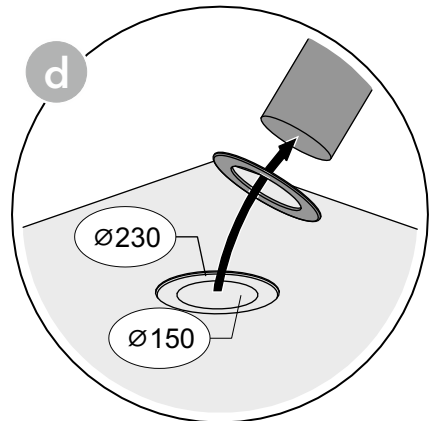
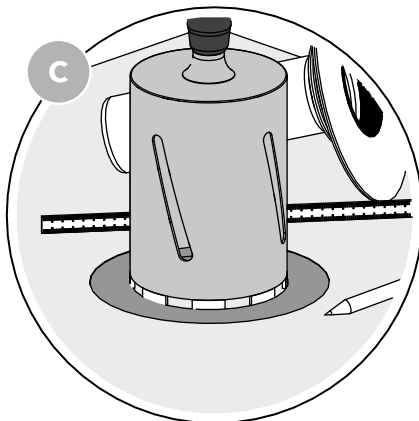
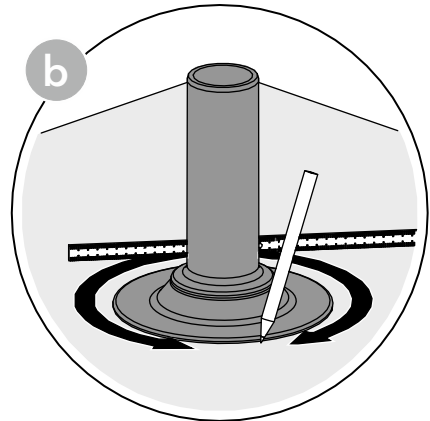
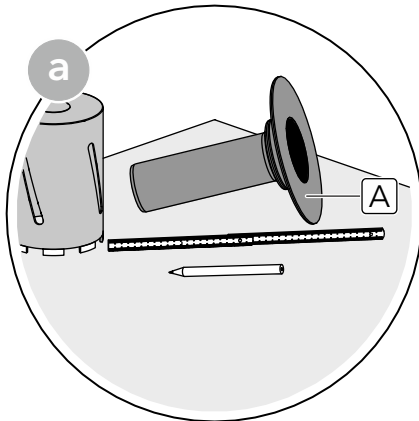
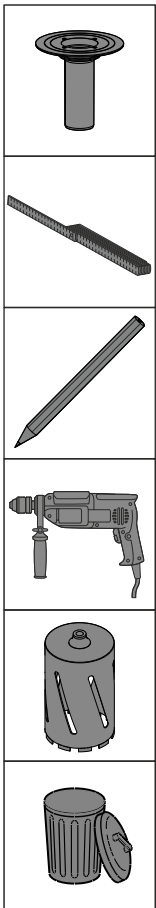

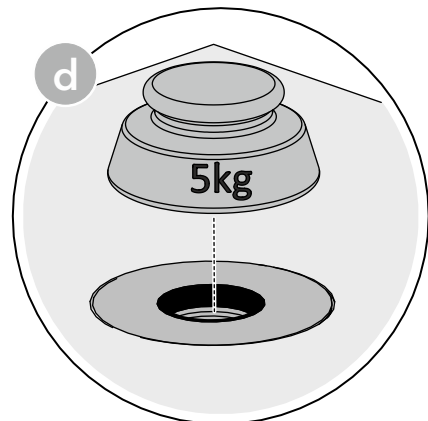
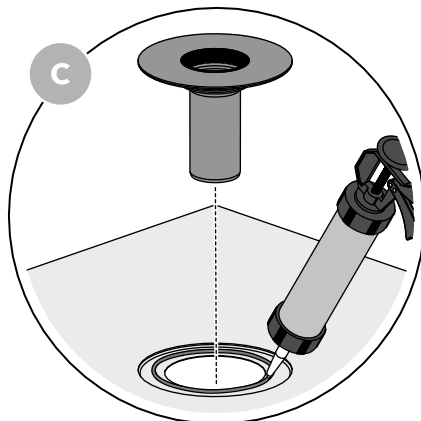
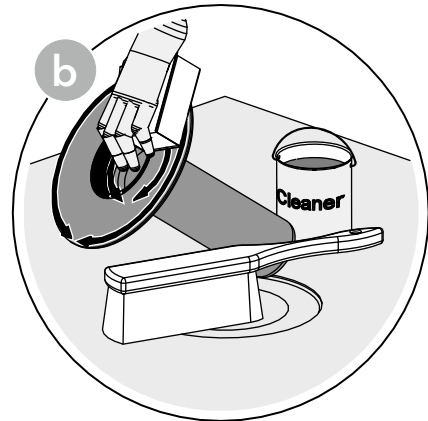
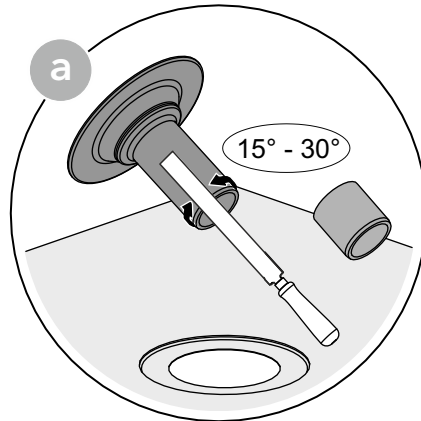
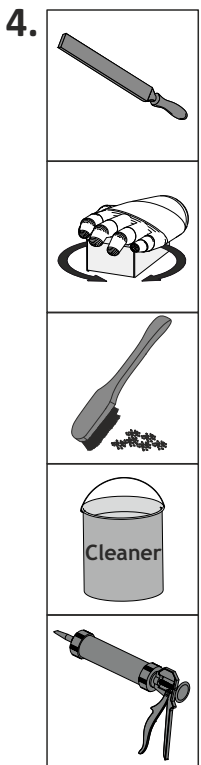
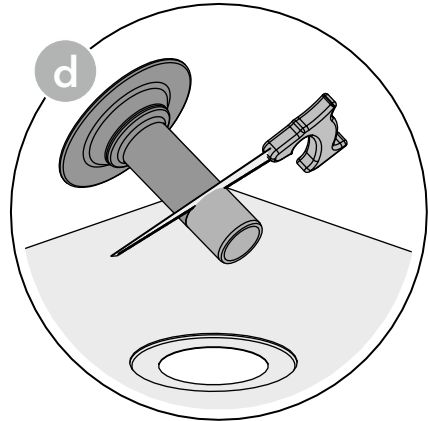
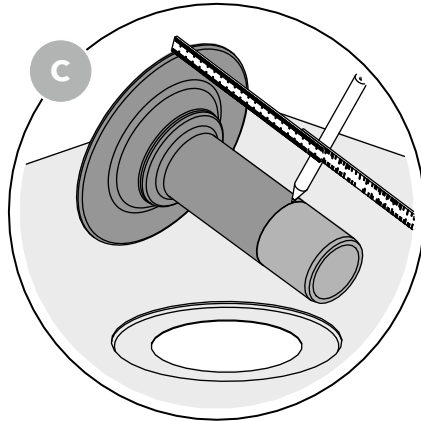
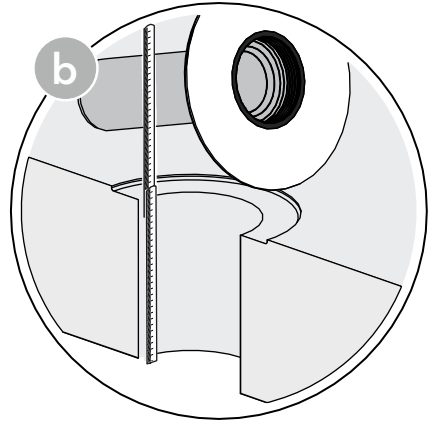
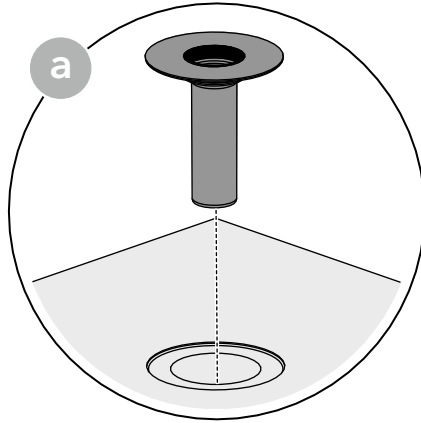
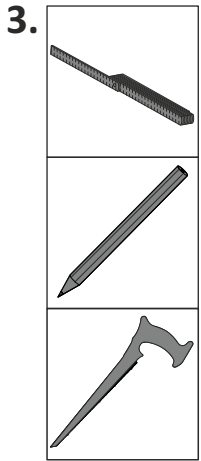

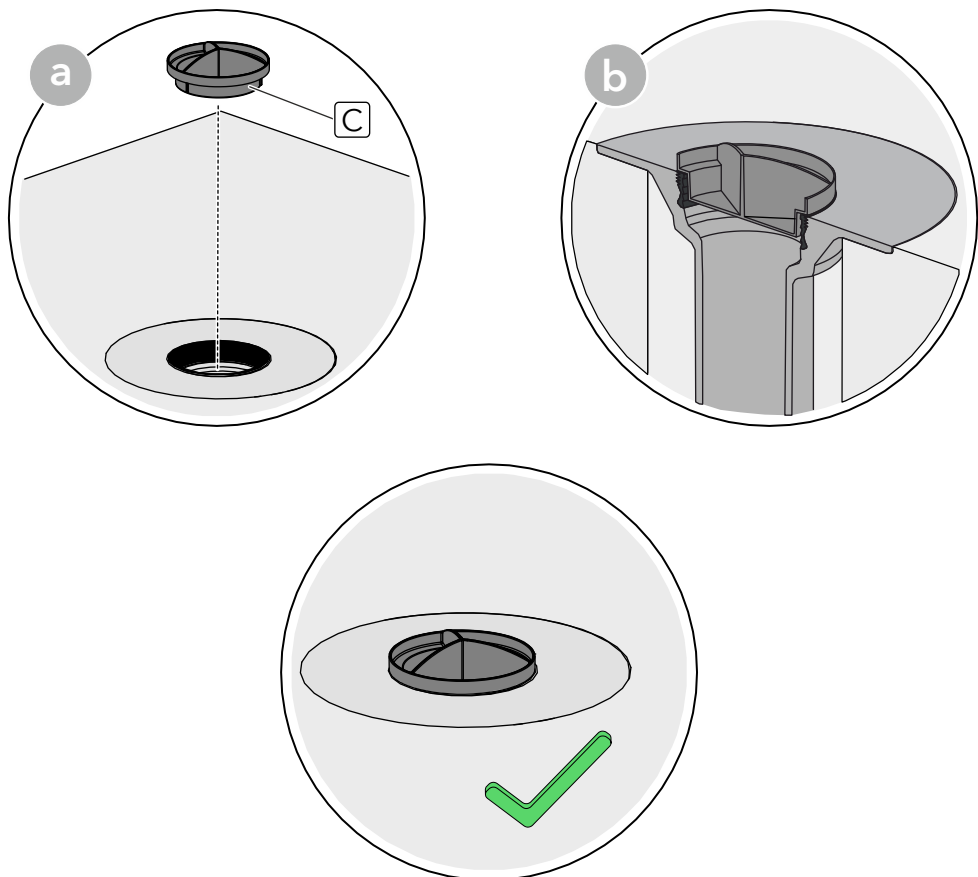
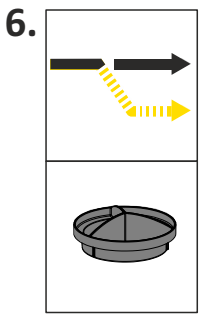
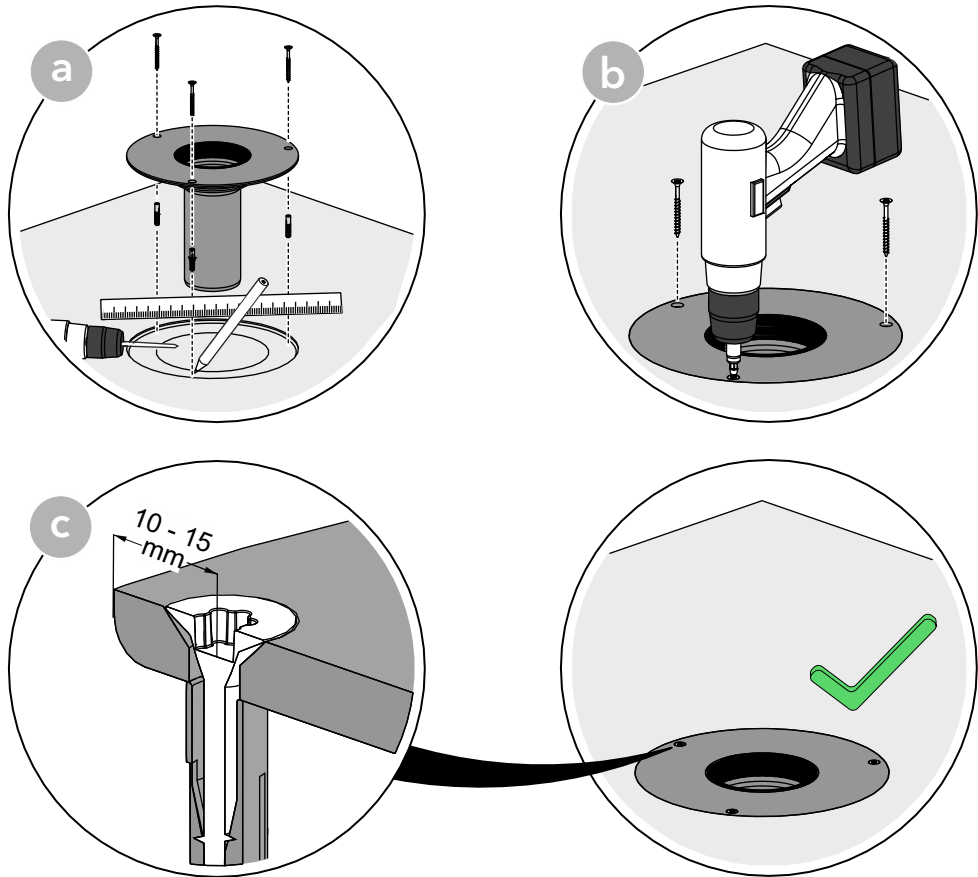
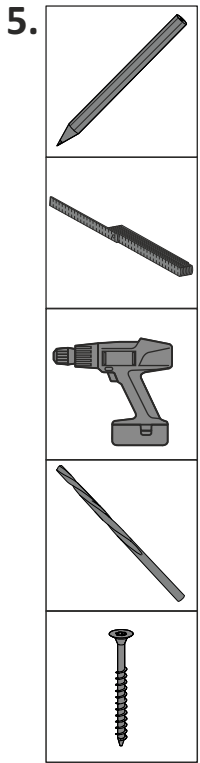

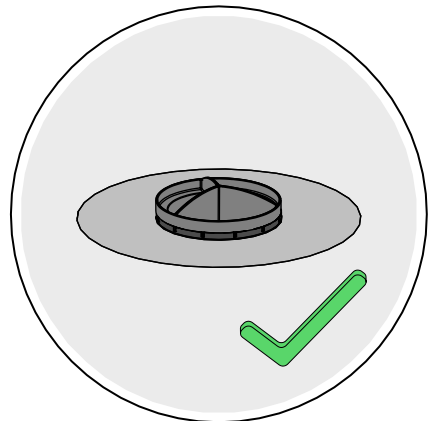
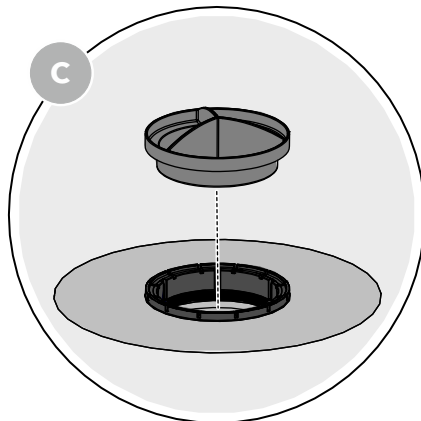
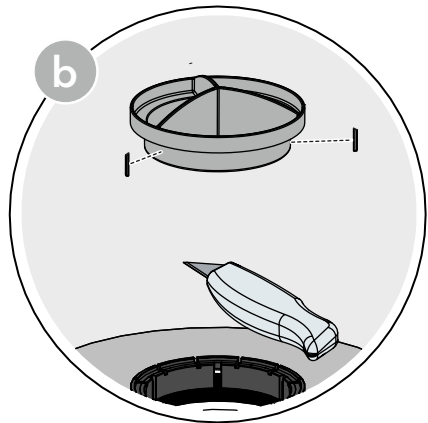
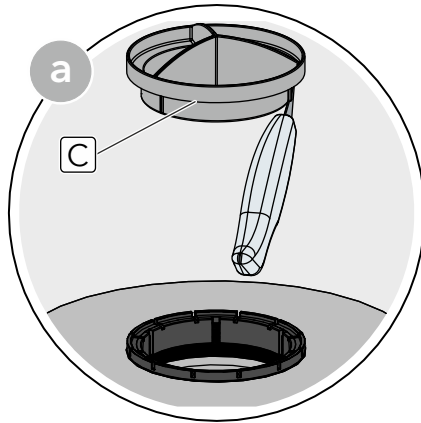
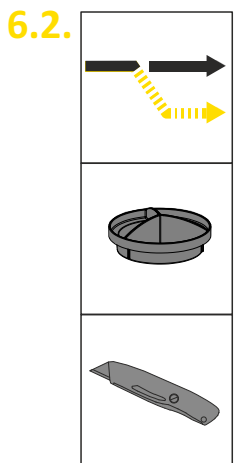
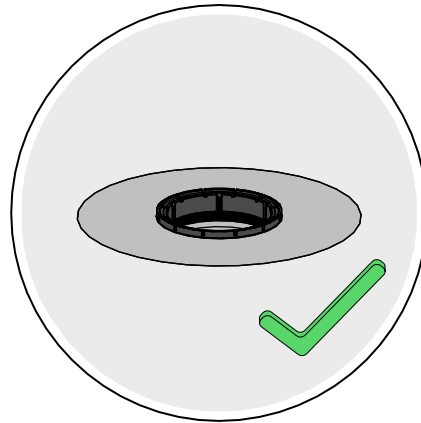
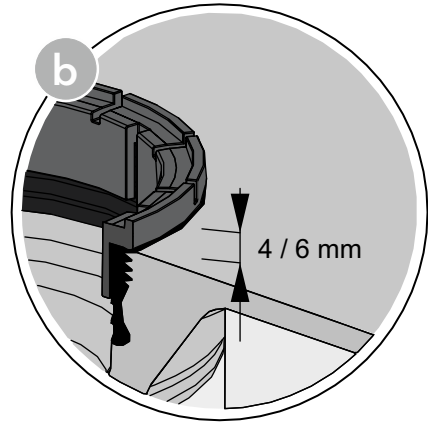
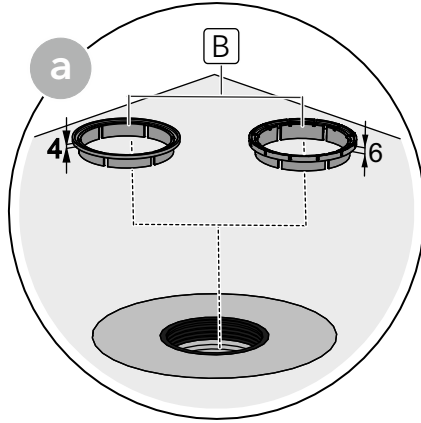
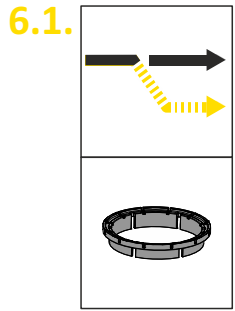

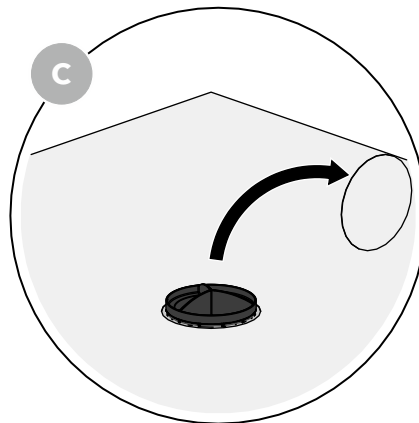
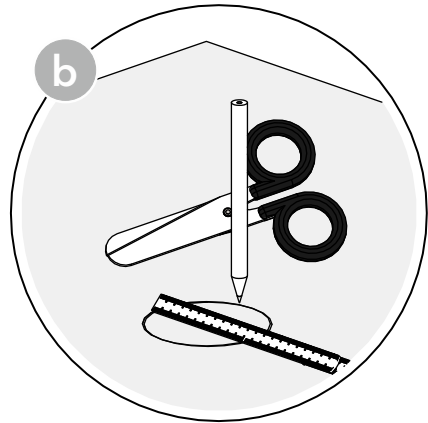
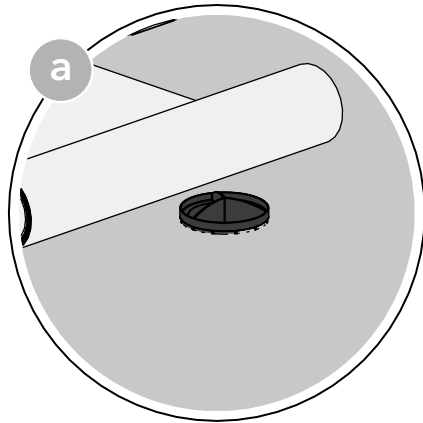
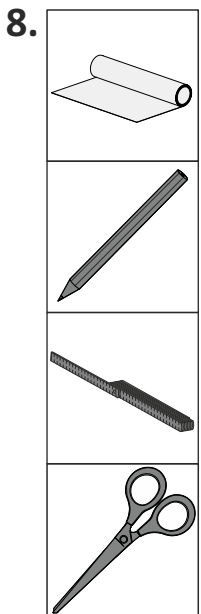
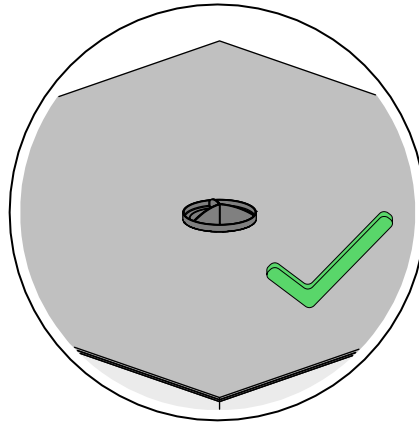
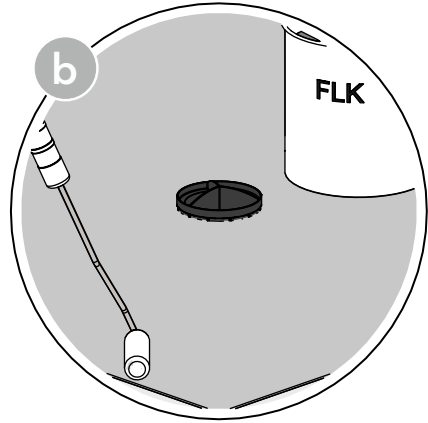
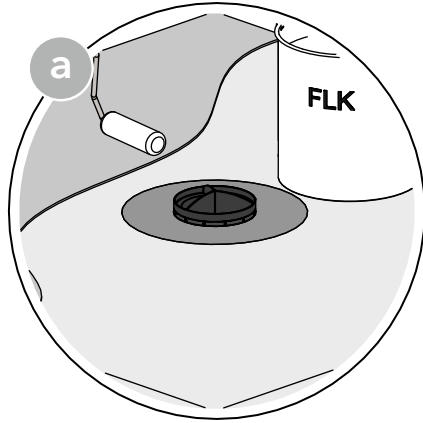
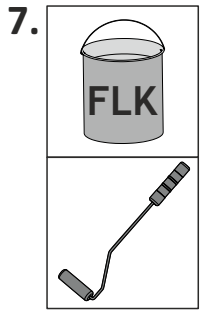

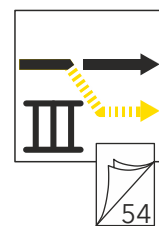
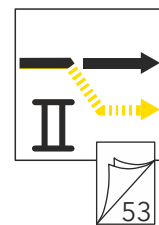
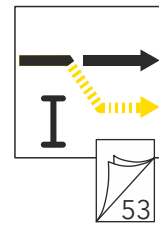
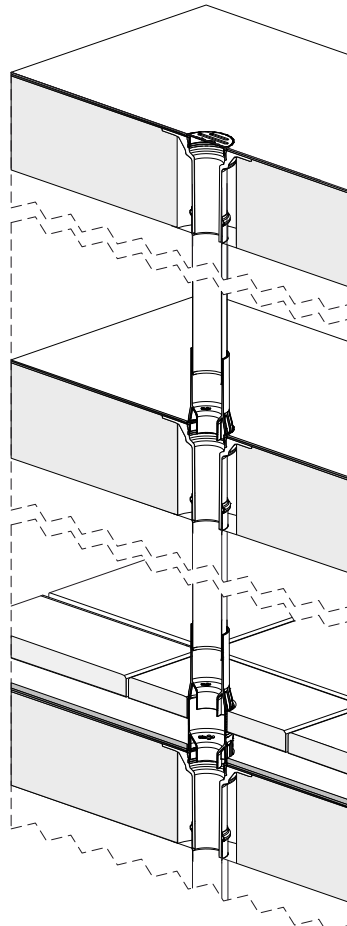
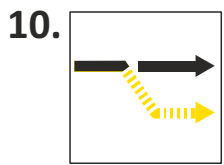
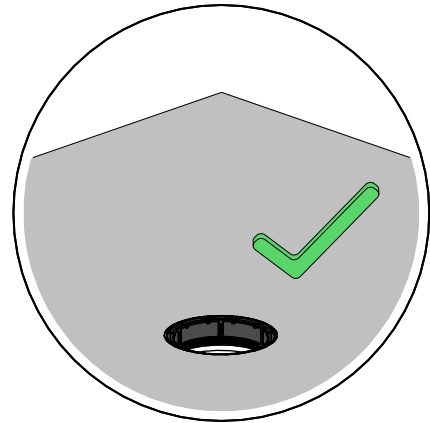
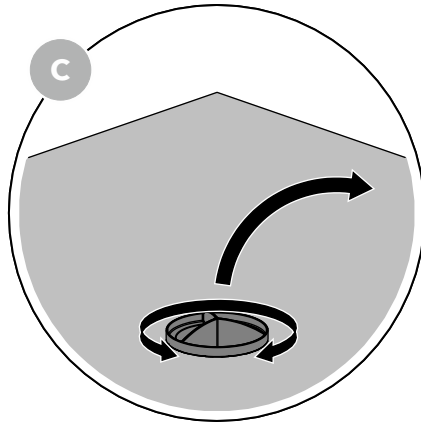
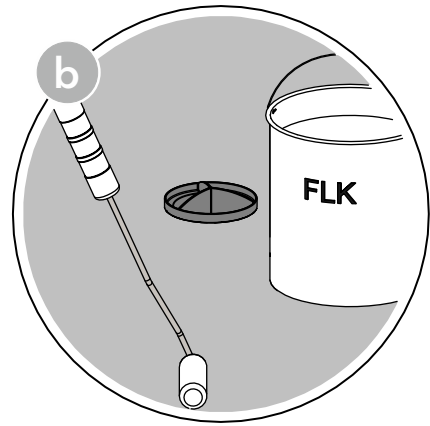
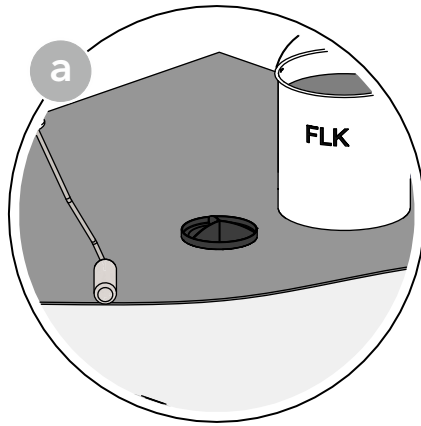
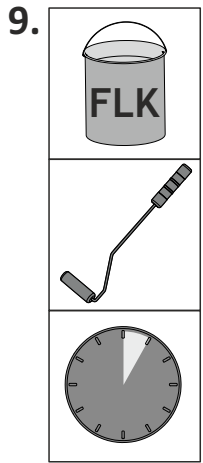

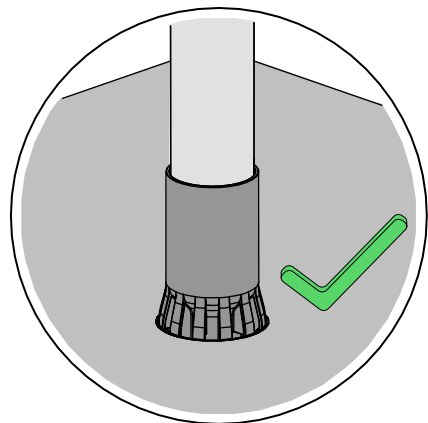
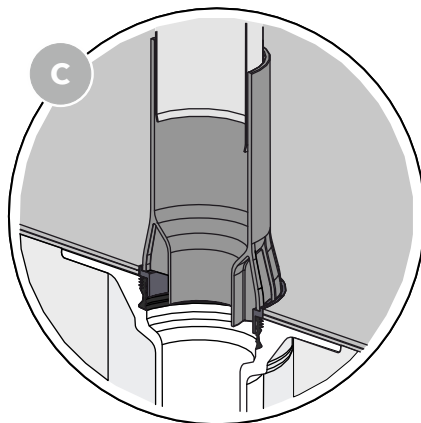
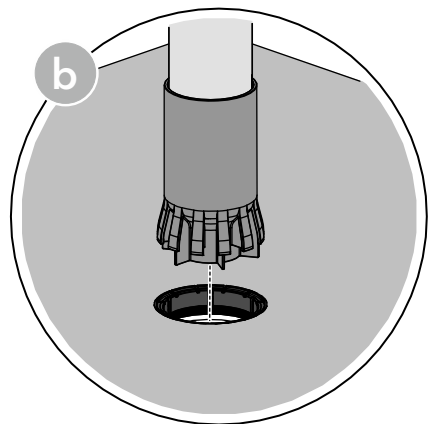
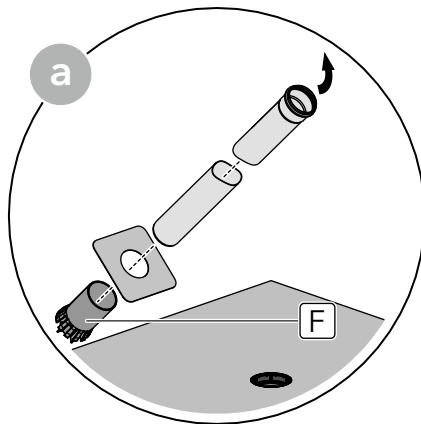
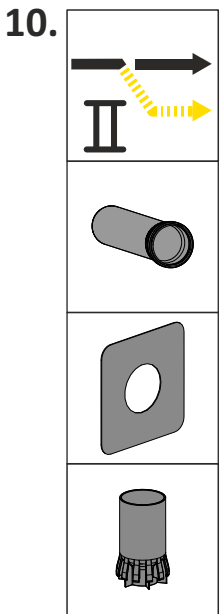
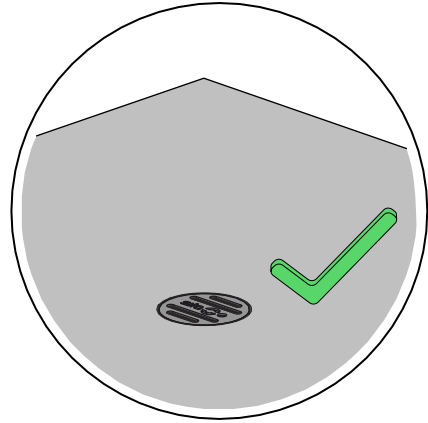
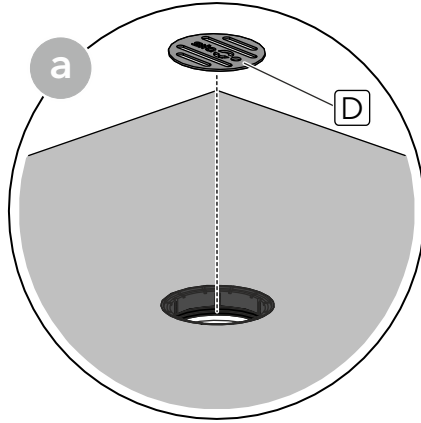
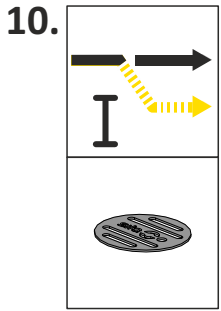



10.1.

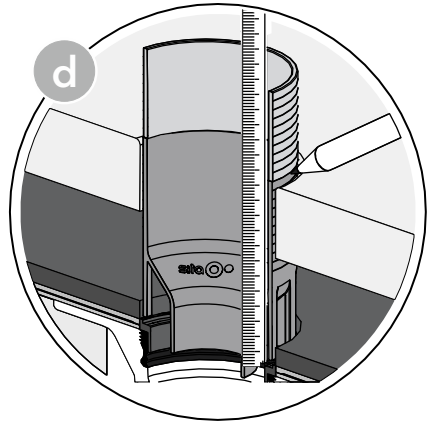
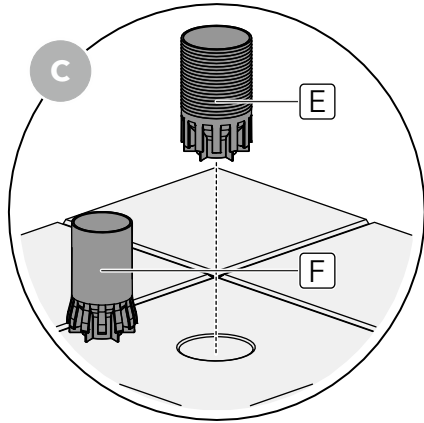
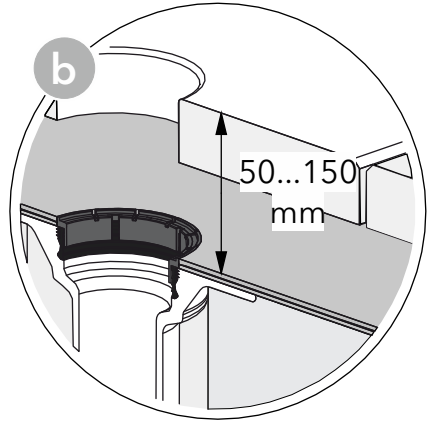
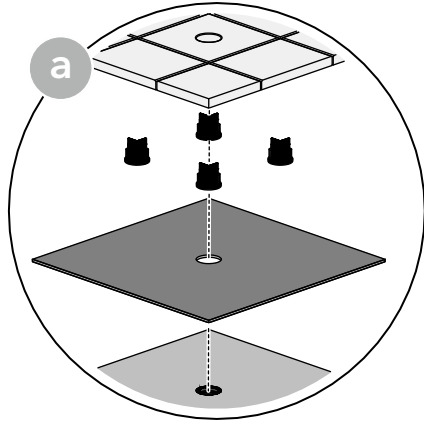

10.2.

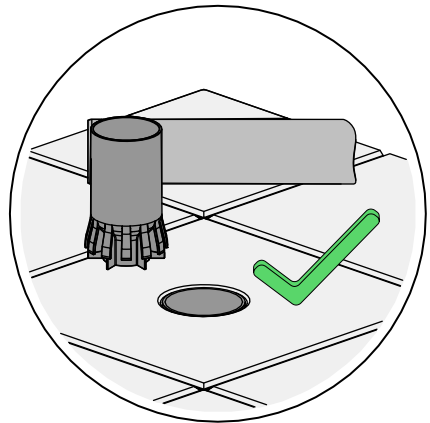
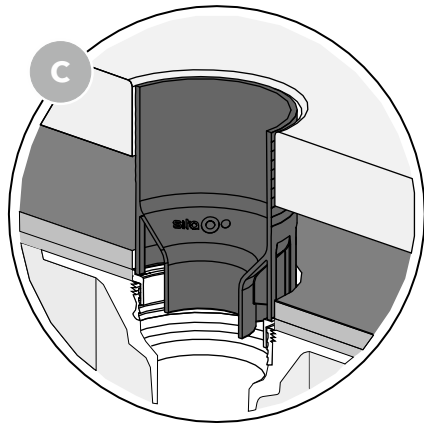
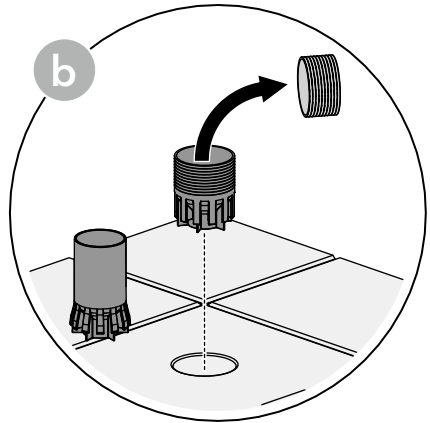
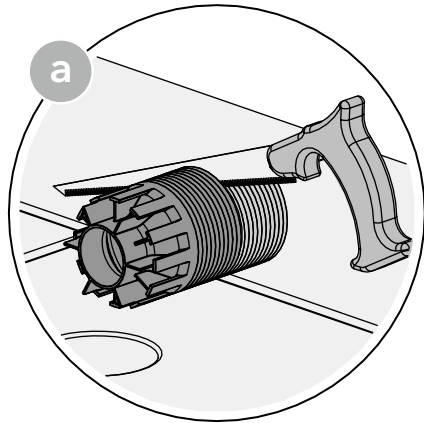
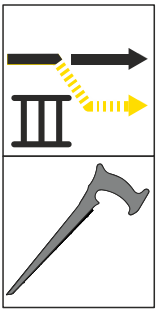



10.3.

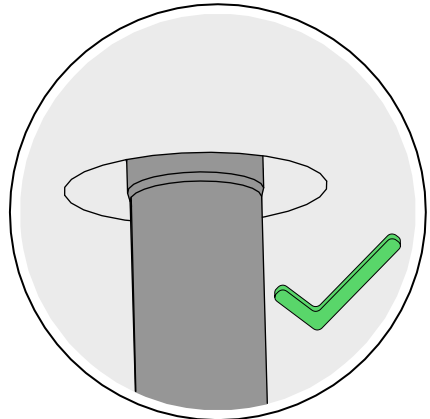
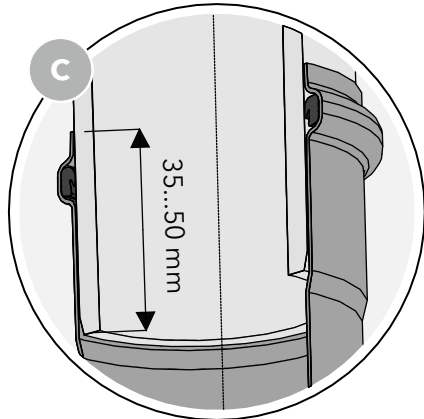
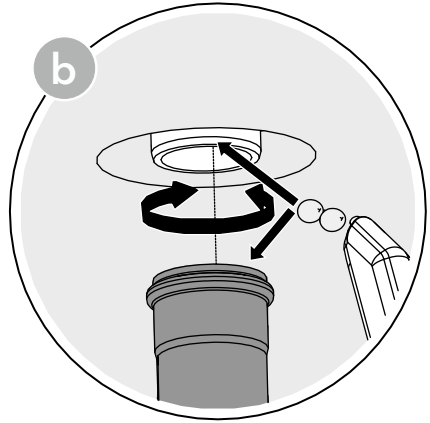
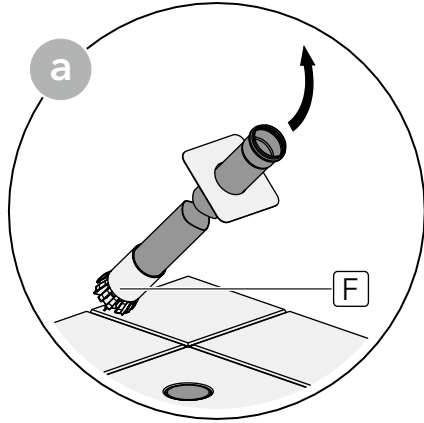
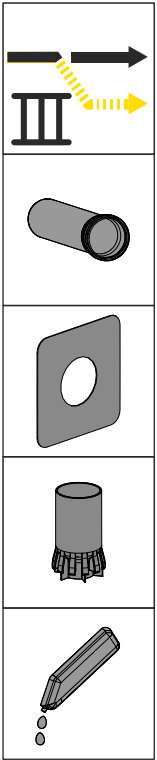

10.4.

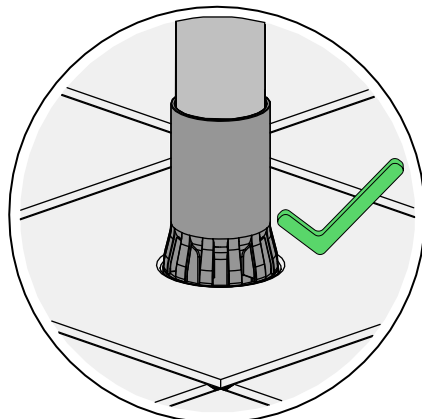
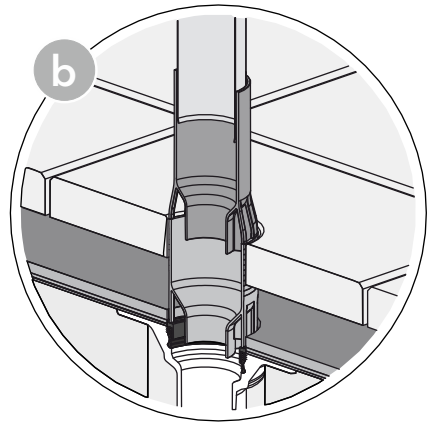
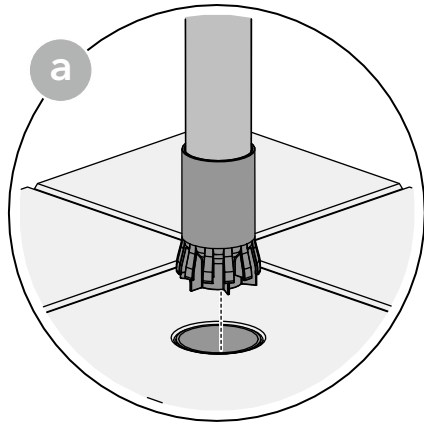
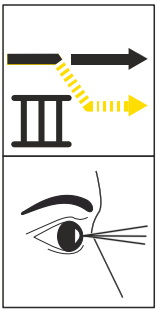



11.

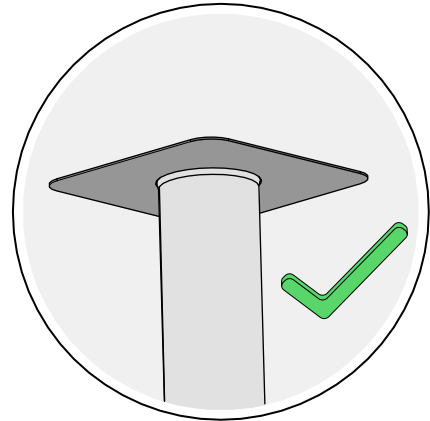
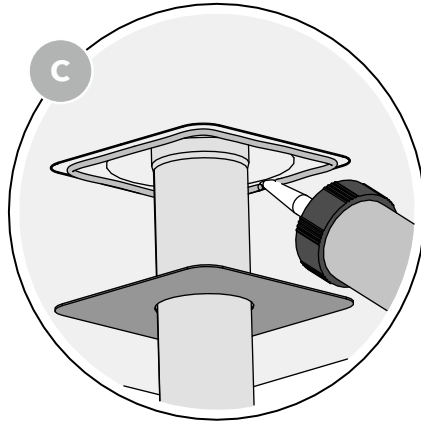
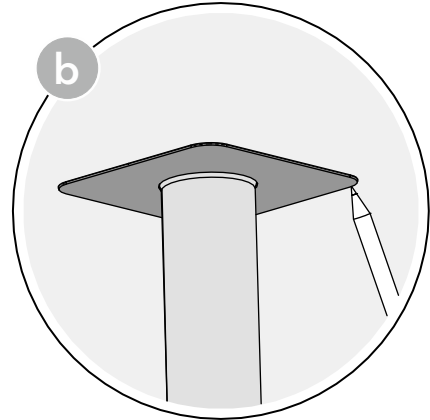
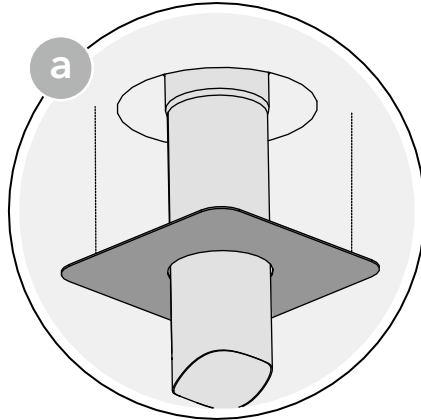
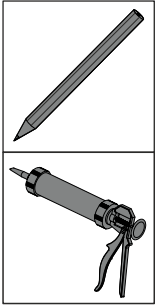

12.

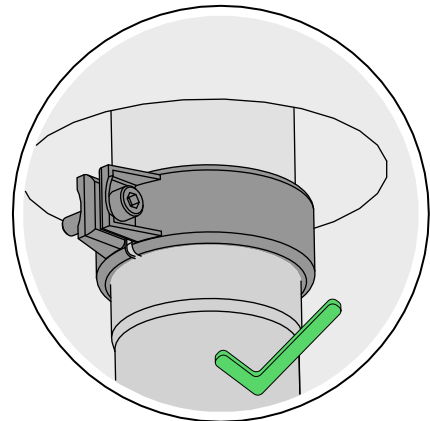
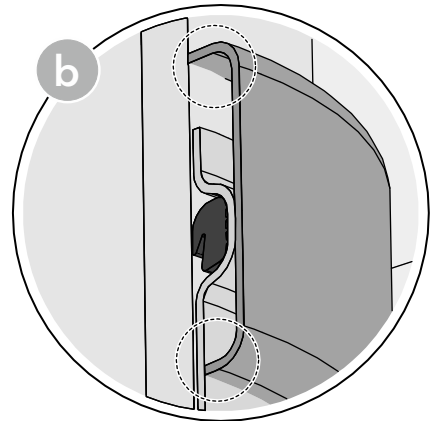
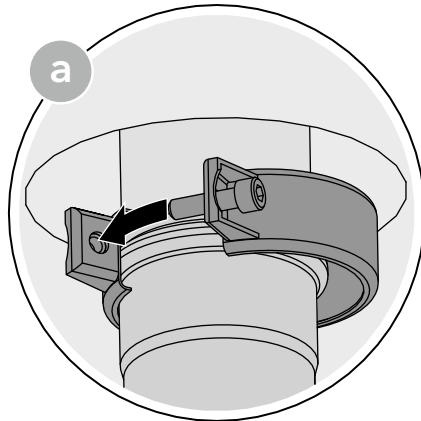
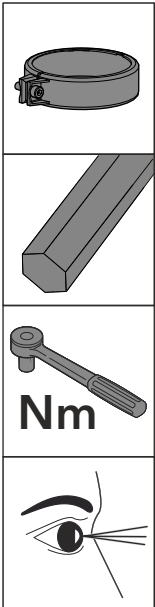



DE	3.5 SitaCompact Anstauring
EN	3.5 SitaCompact retaining ring
FR	3.5 SitaCompact trop-plein
NL	3.5 SitaCompact overloop
PL	3.5 SitaCompact pierścień spiętrzający
RU	3.5 Подпорный элемент SitaCompact
TR	3.5 SitaCompact Taşma Halkası

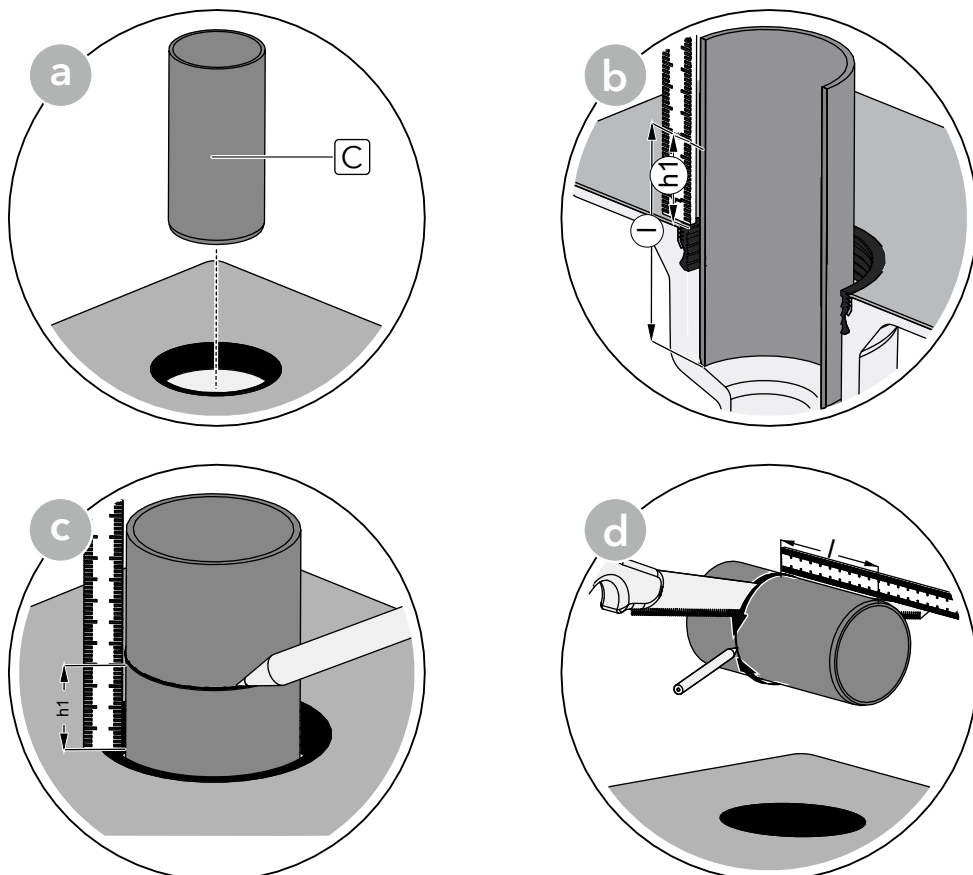
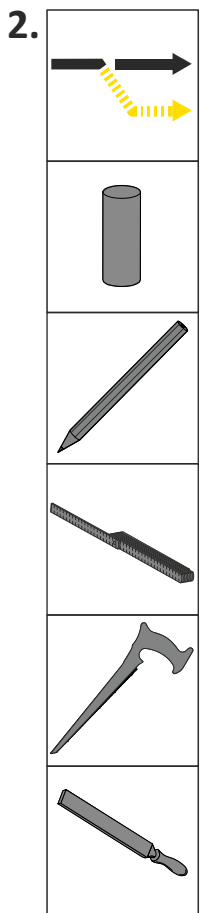
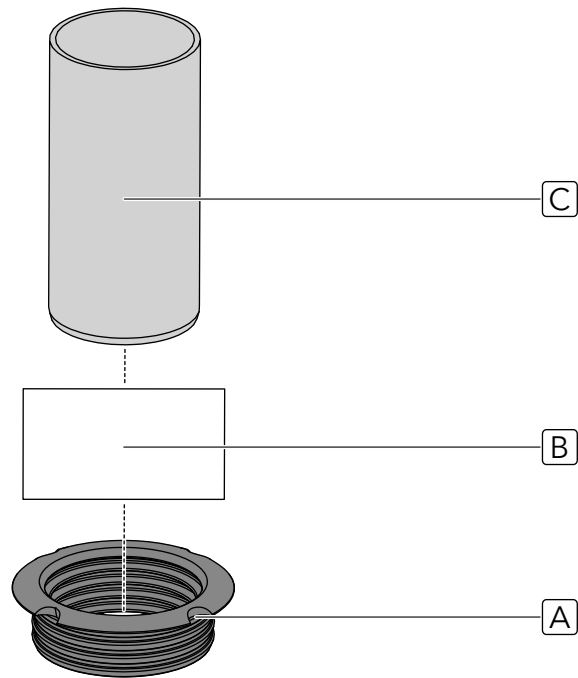
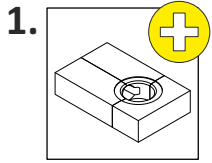

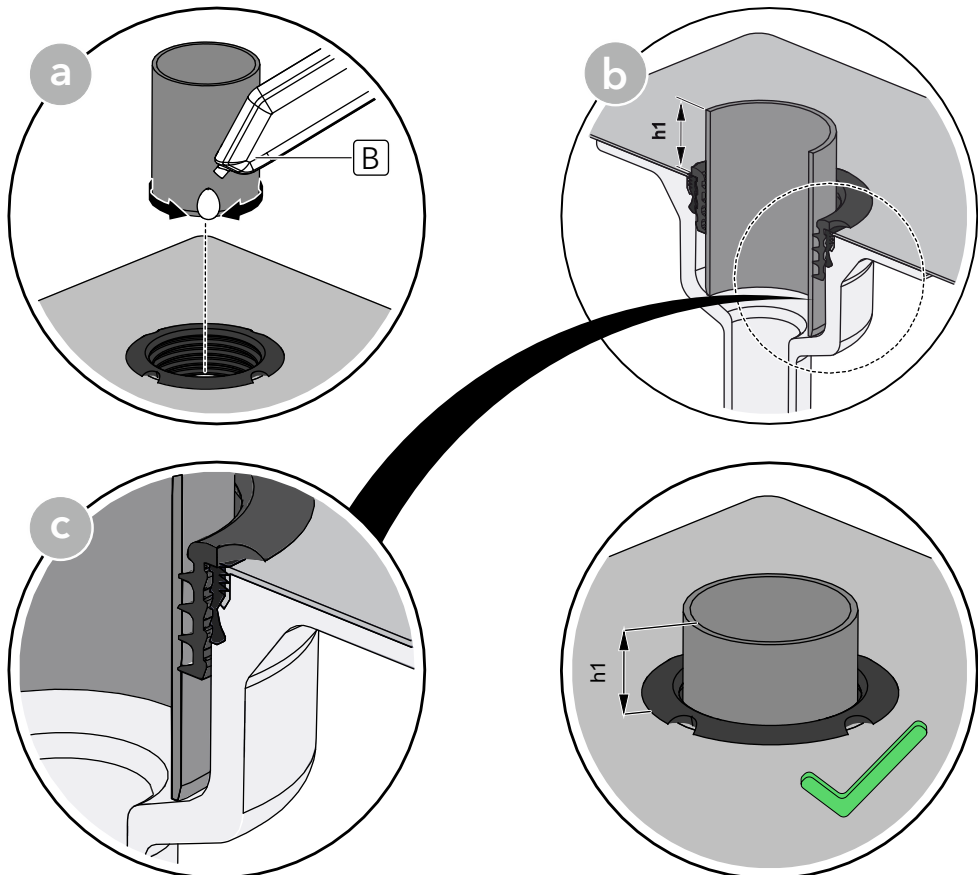
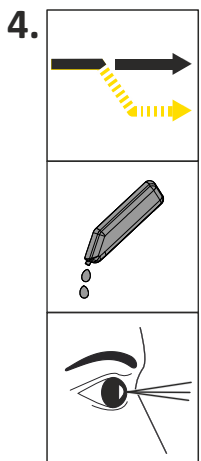
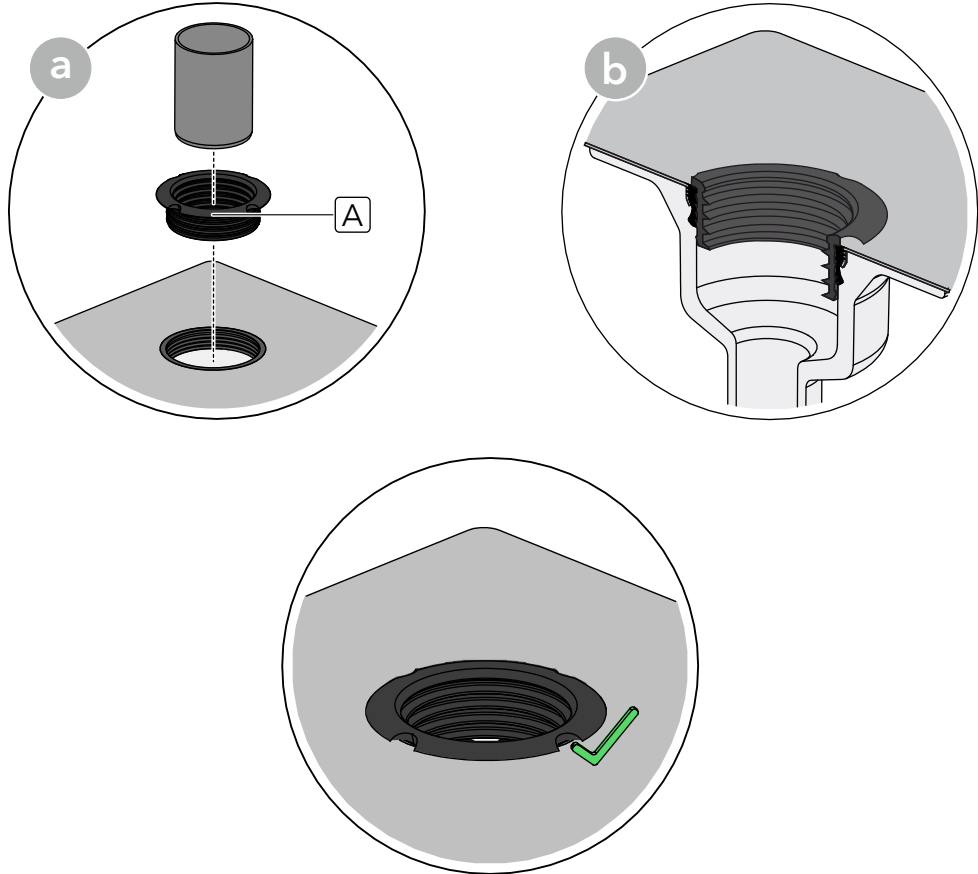
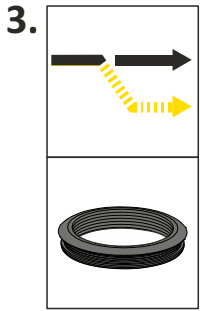

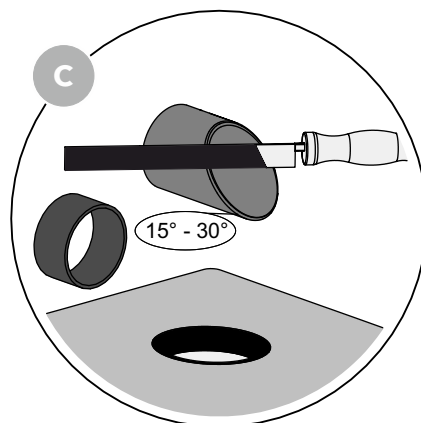
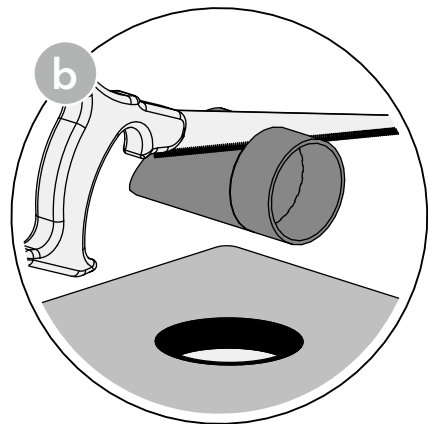
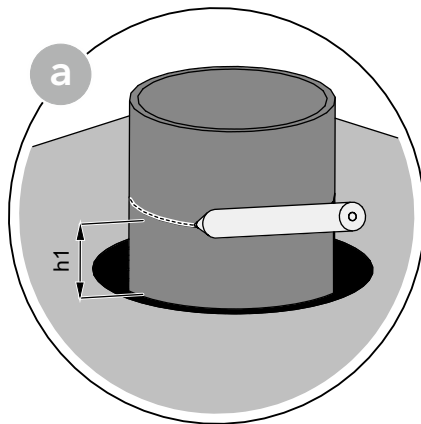
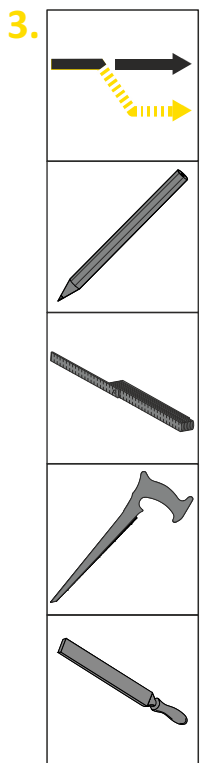
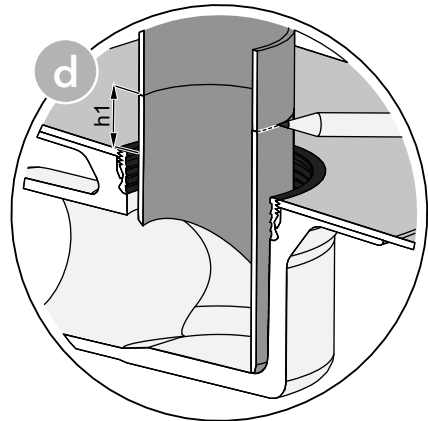
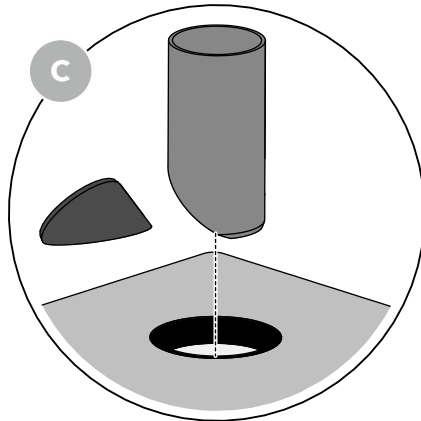
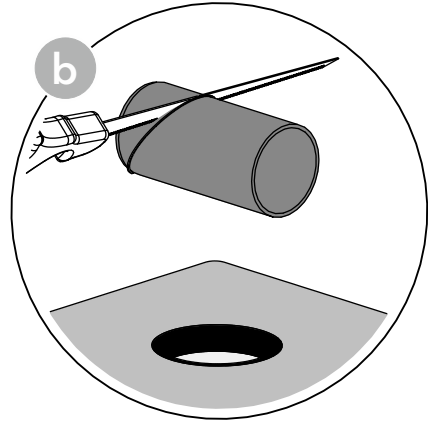
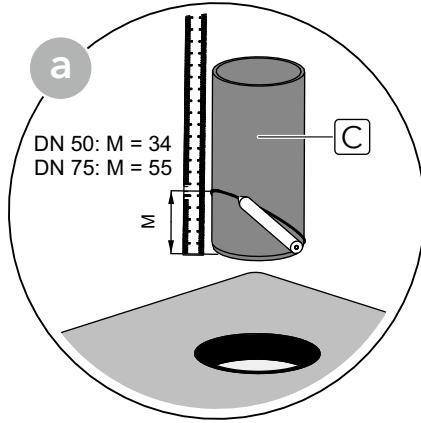
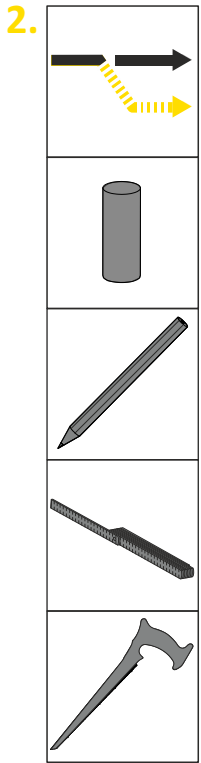

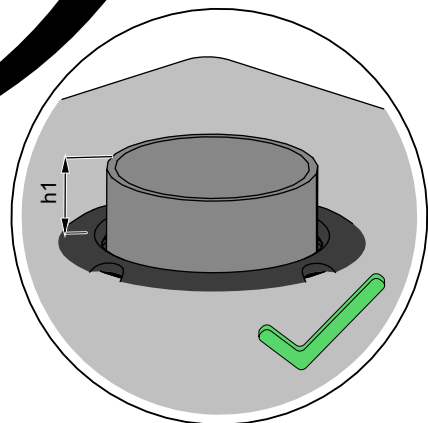
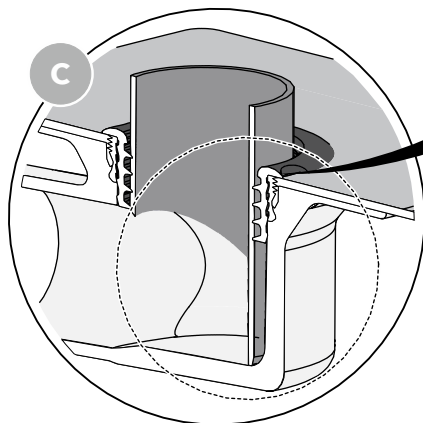
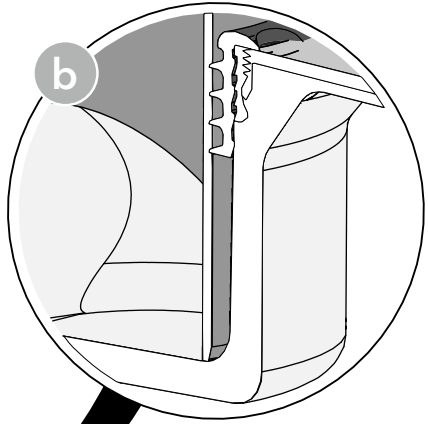
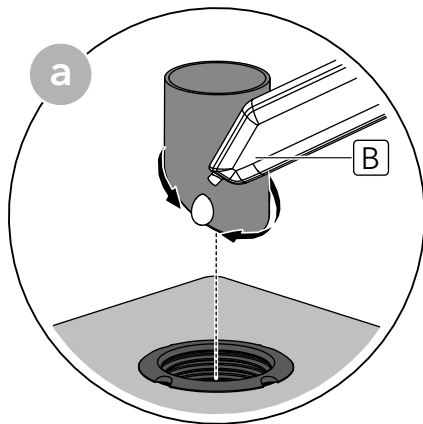
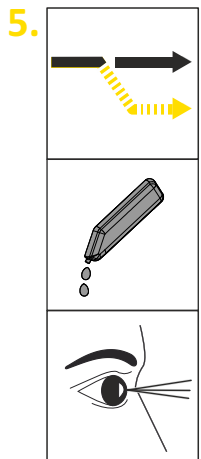
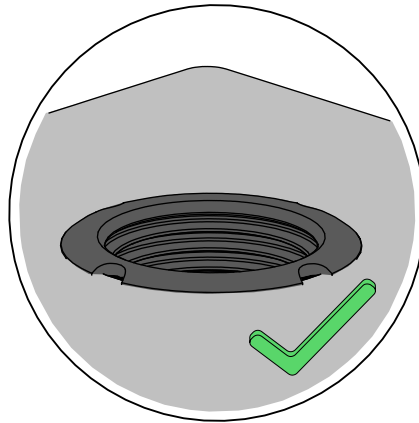
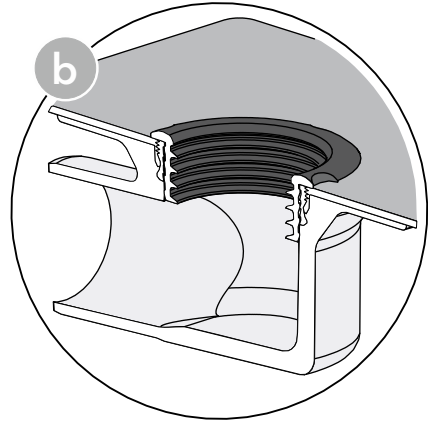
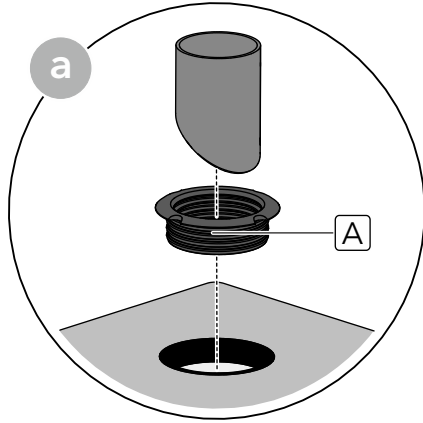
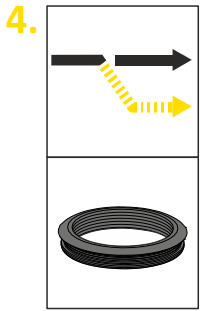



DE	3.6 SitaCompact Balkonaufsatz
EN	3.6 SitaCompact balcony grating
FR	3.6 SitaCompact Couronnement et grille pour balcon
NL	3.6 SitaCompact balkonopzetframe
PL	3.6 SitaCompact nasadka balkonowa
RU	3.6 Балконная насадка SitaCompact
TR	3.6 SitaCompact balkon başlığı

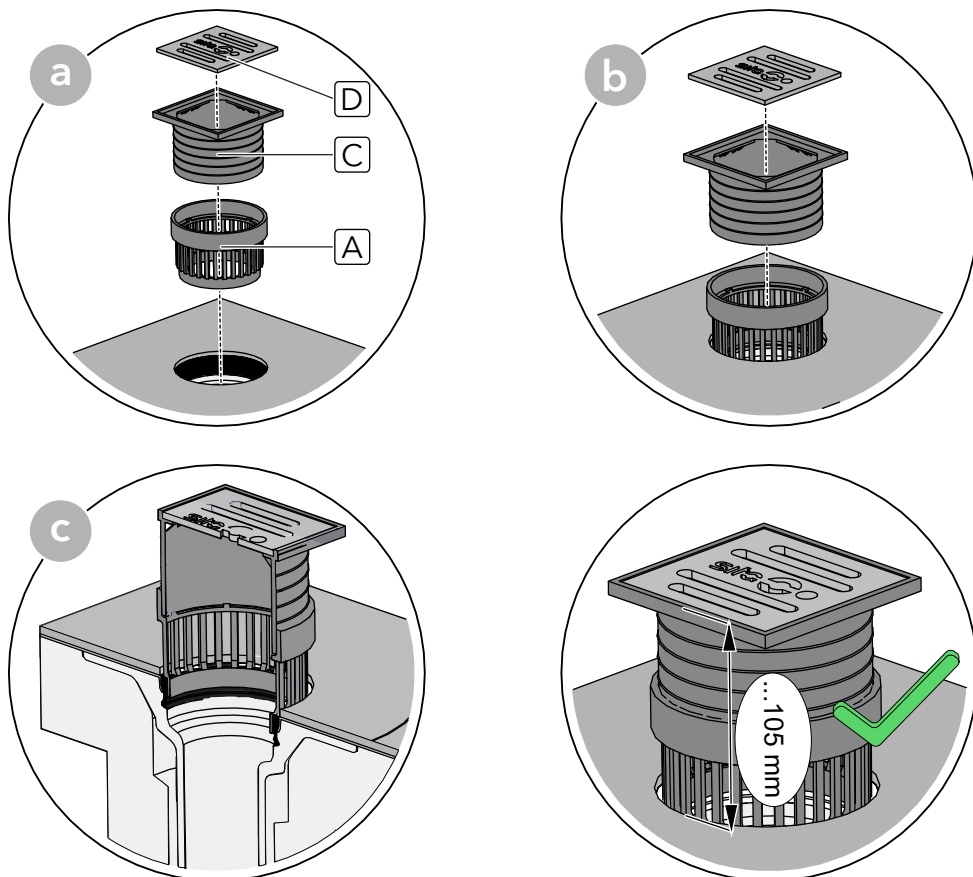
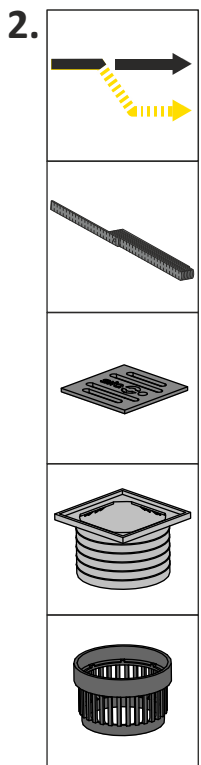
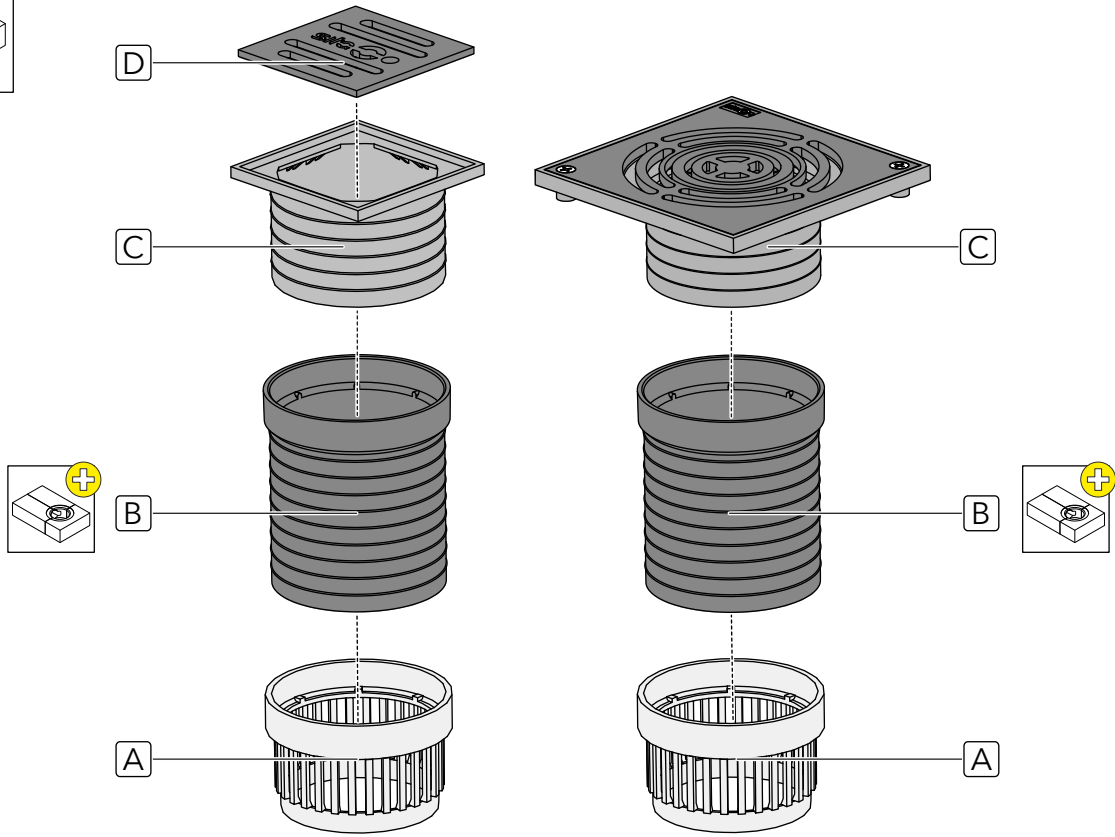
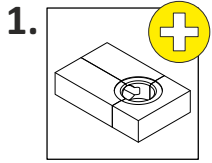

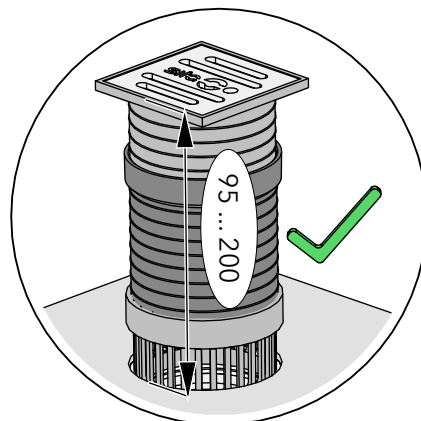
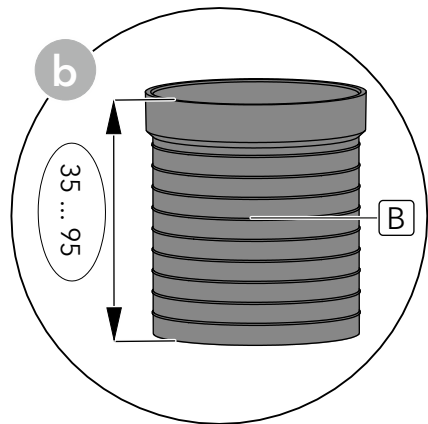
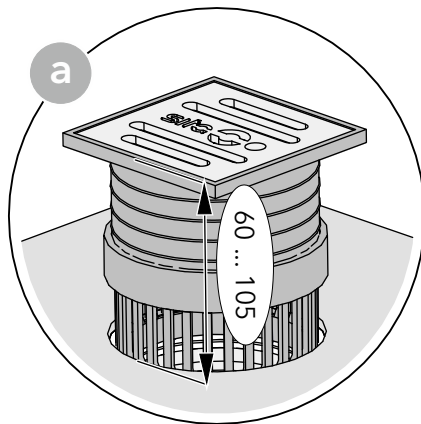
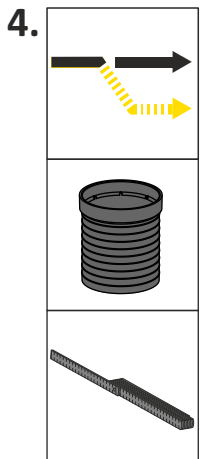
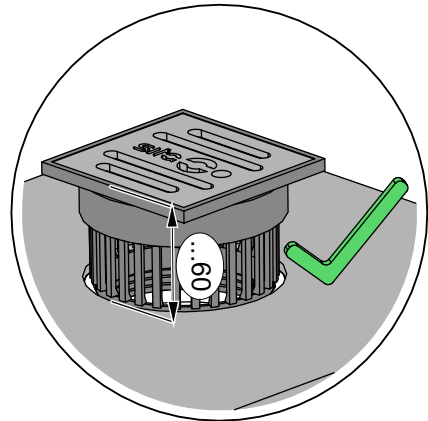
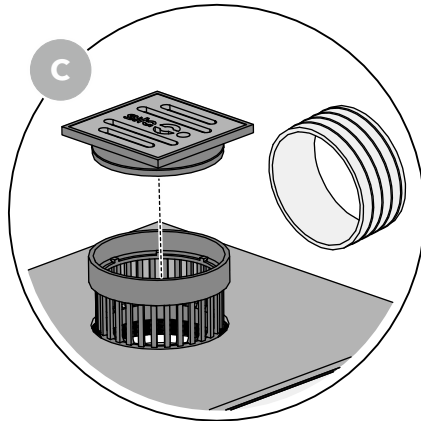
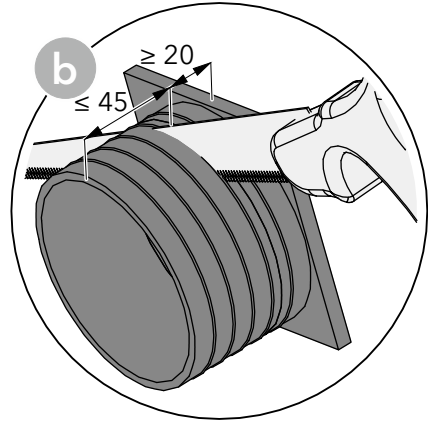
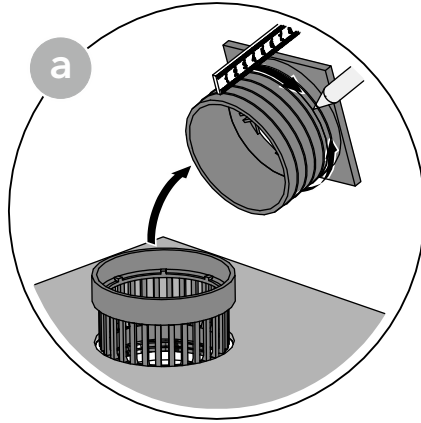
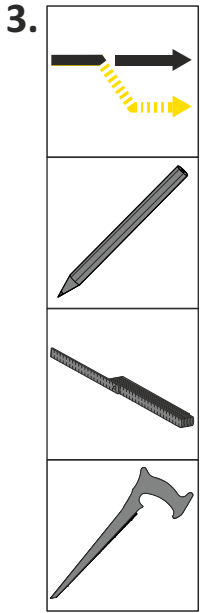

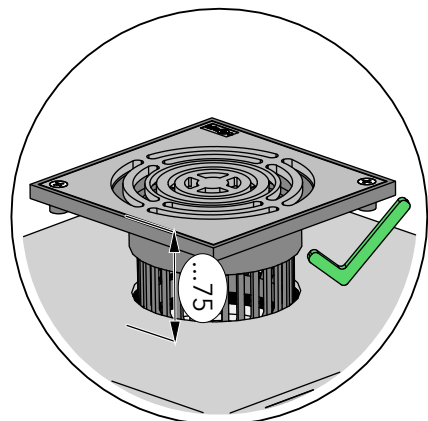
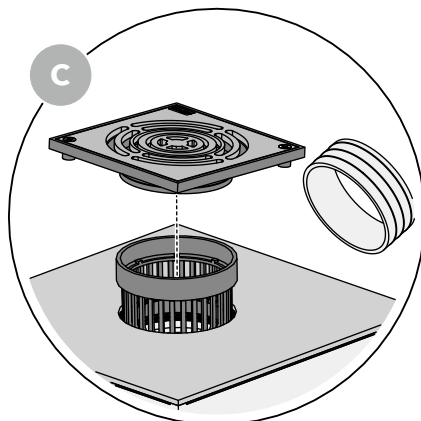
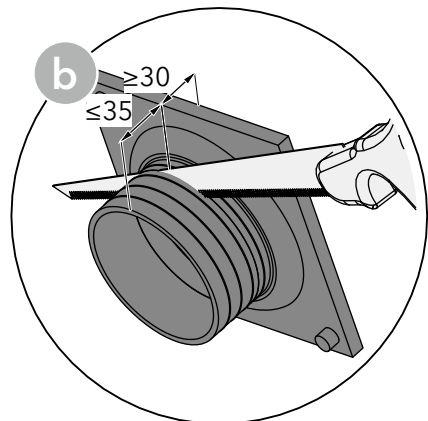
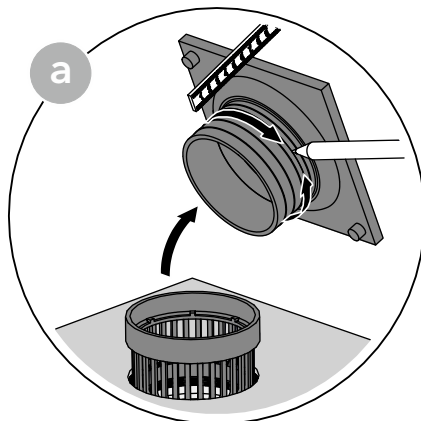
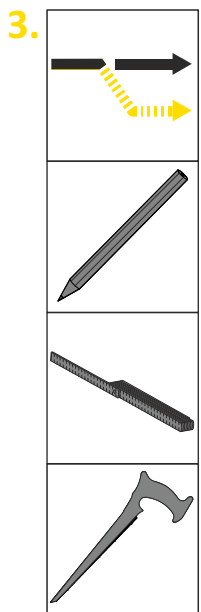
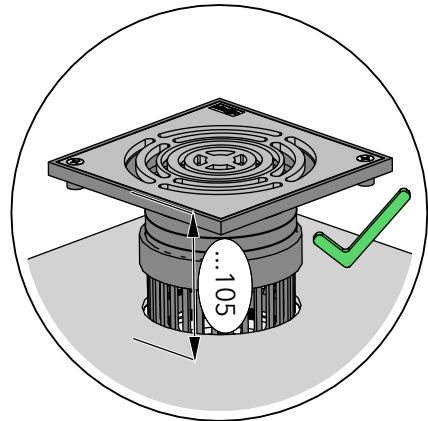
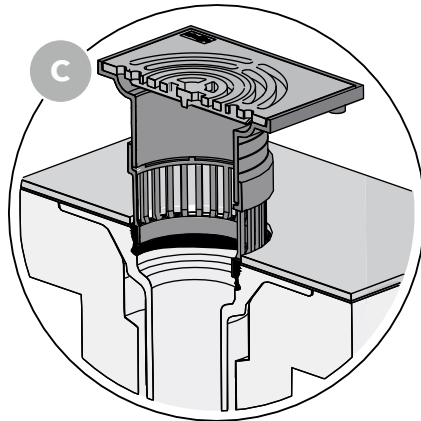
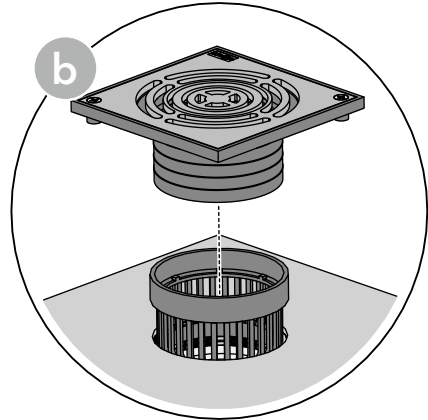
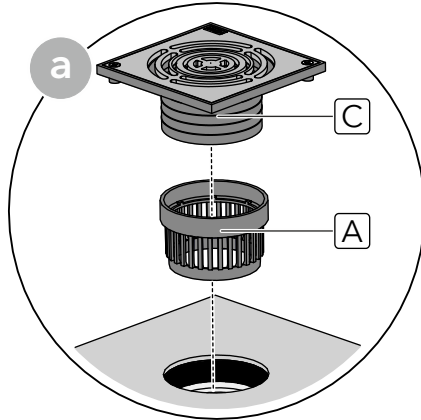
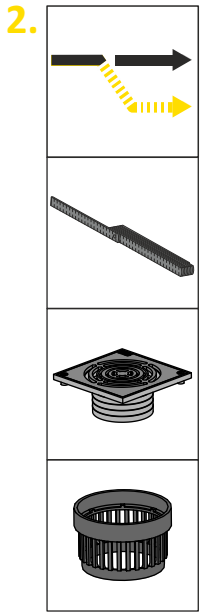

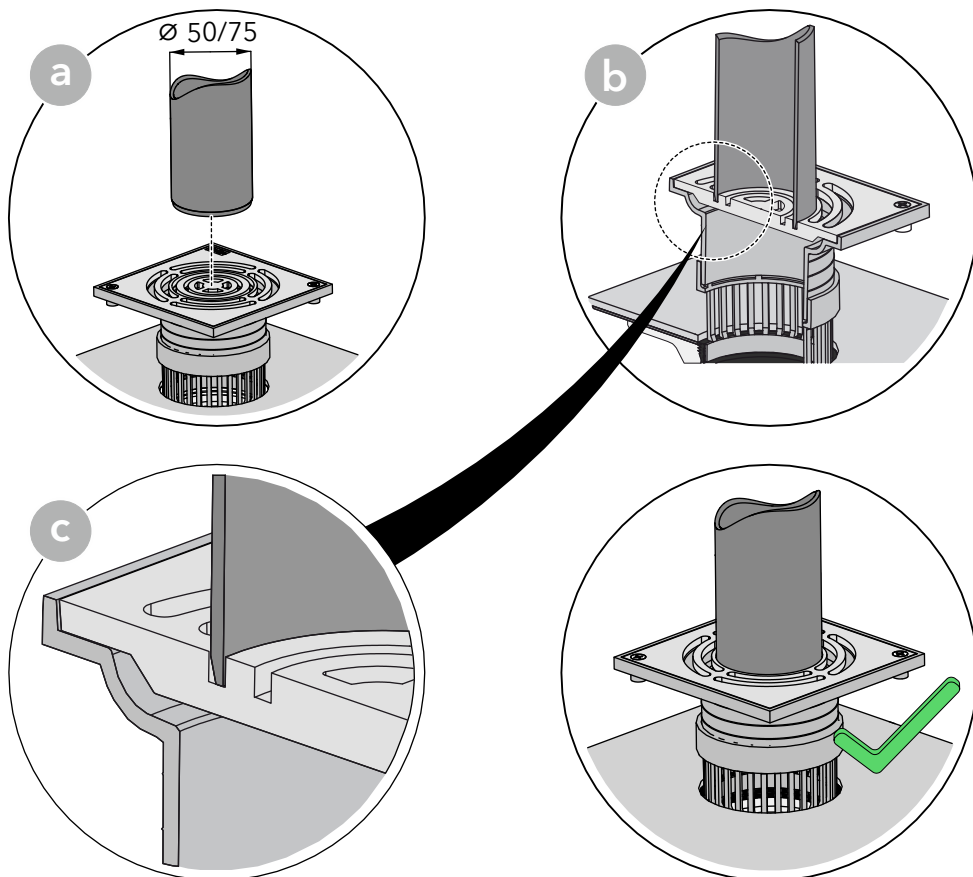
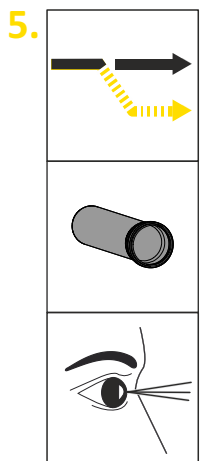
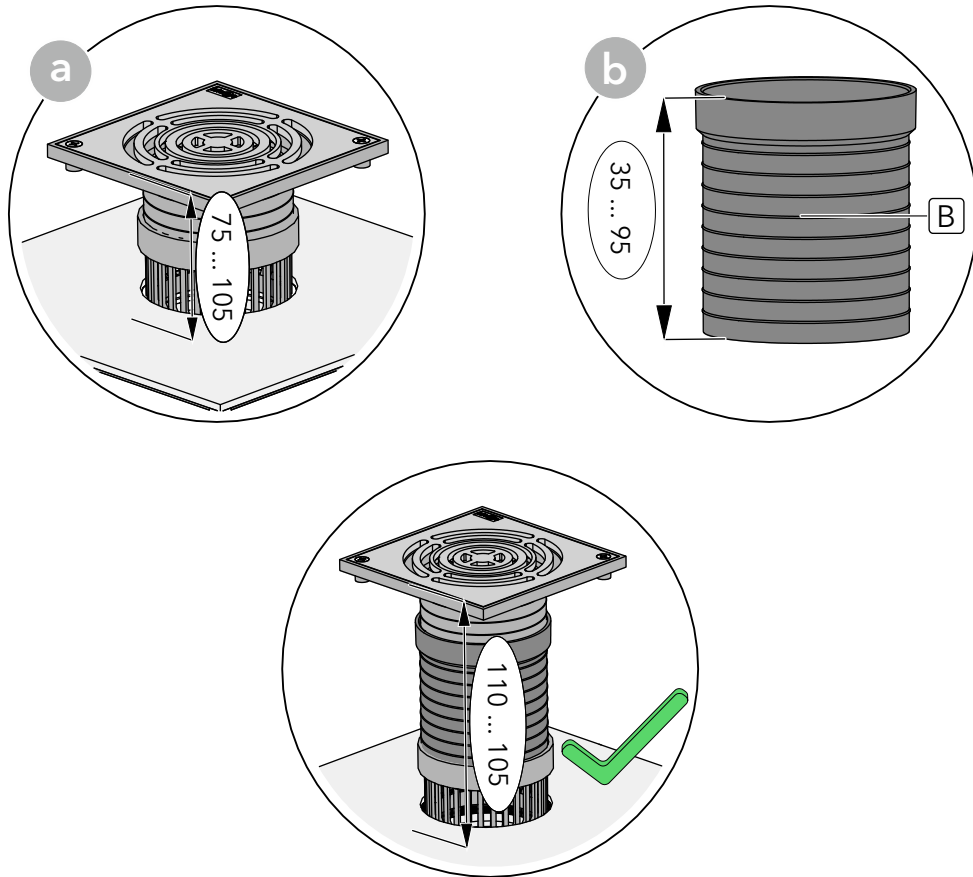
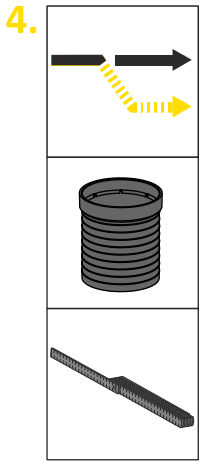



DE	3.7 SitaCarport
EN	3.7 SitaCarport
FR	3.7 SitaCarport
NL	3.7 SitaCarport
PL	3.7 SitaCarport
RU	3.7 SitaCarport
TR	3.7 SitaCarport



1.

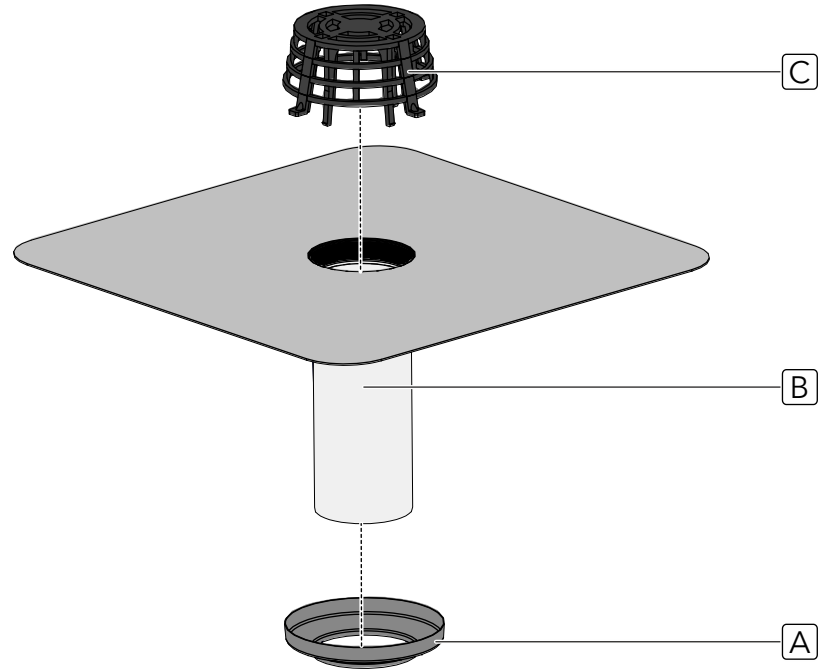

2.

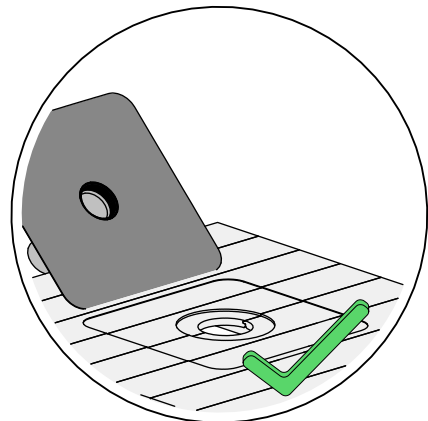
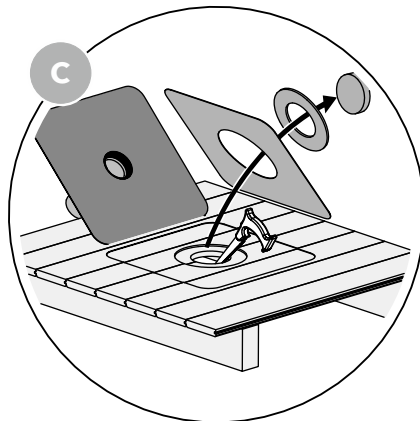
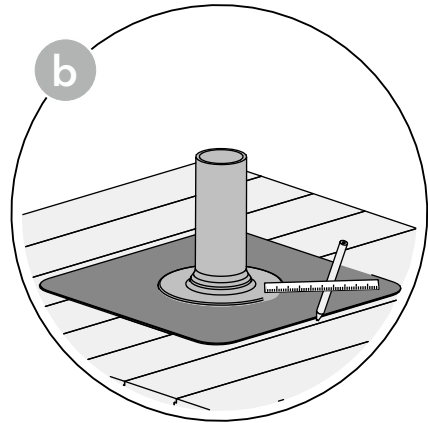
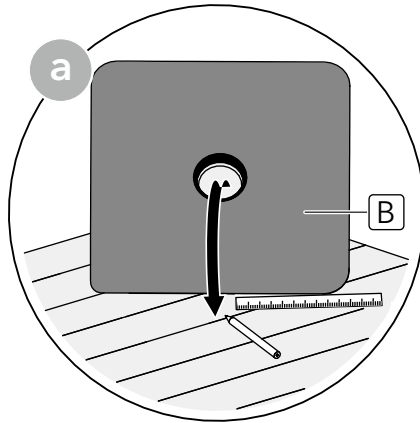
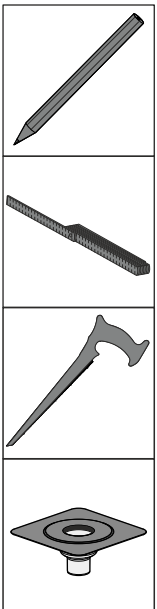

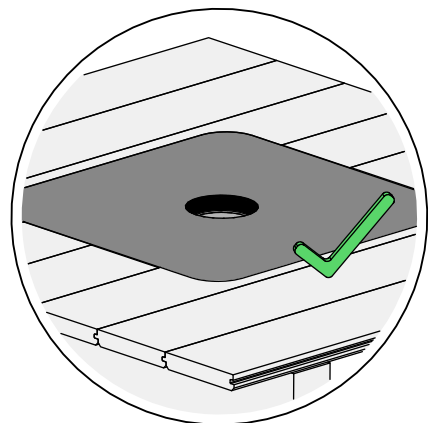
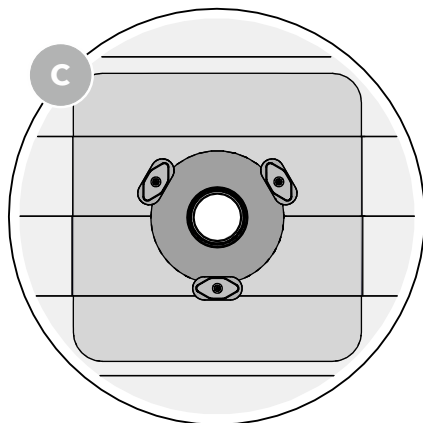
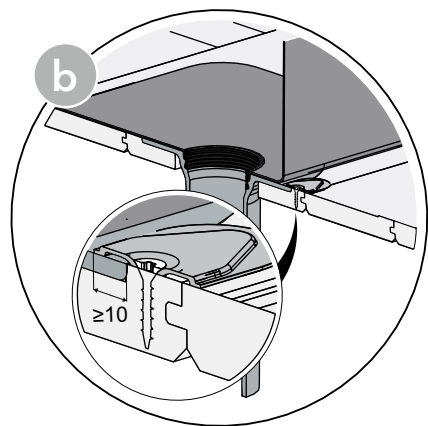
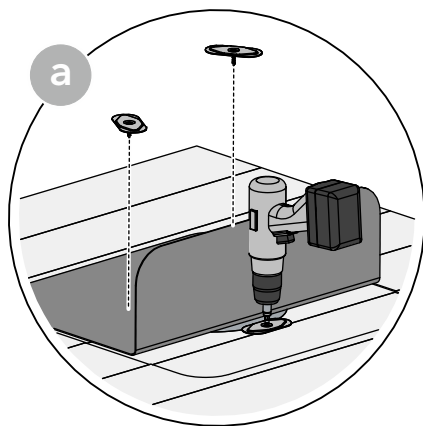
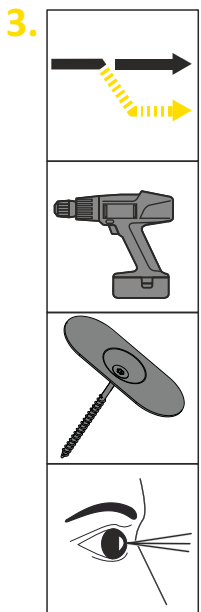
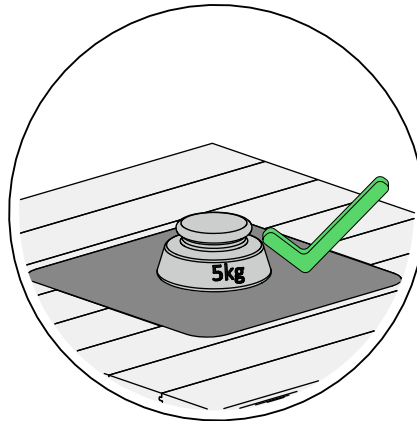
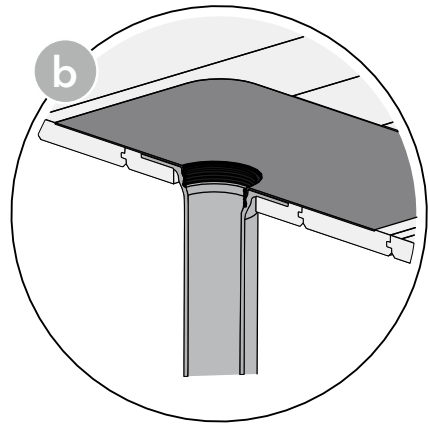
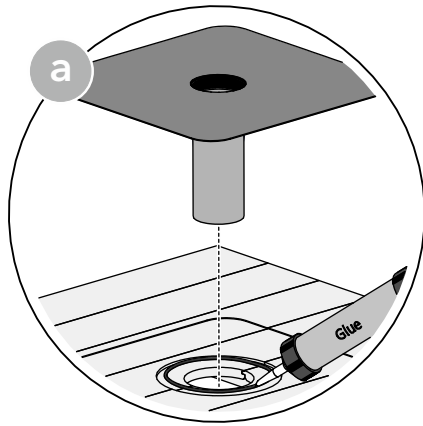
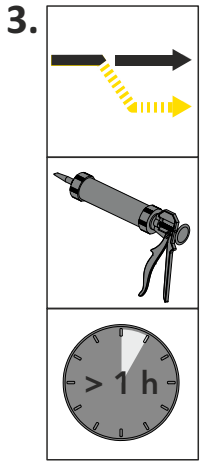

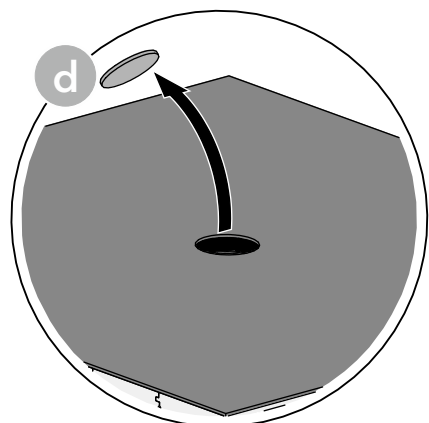
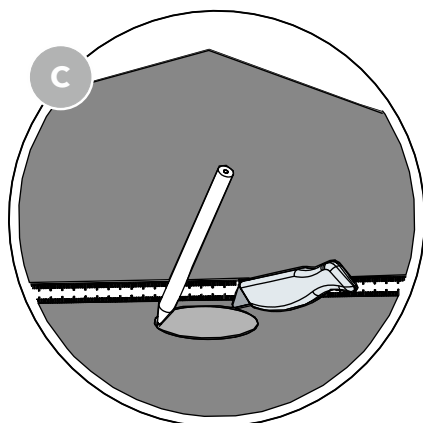
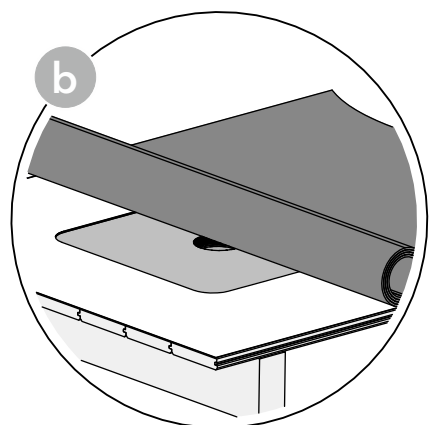
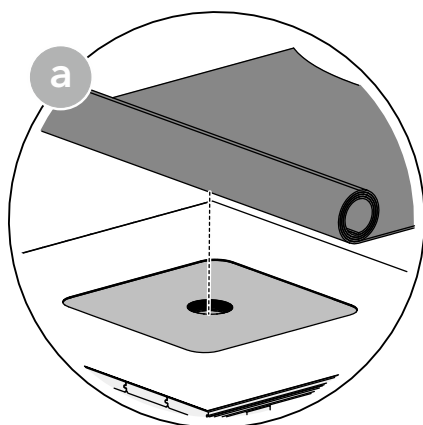
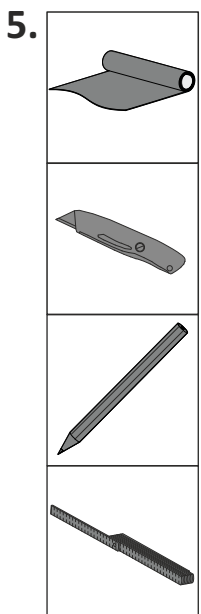
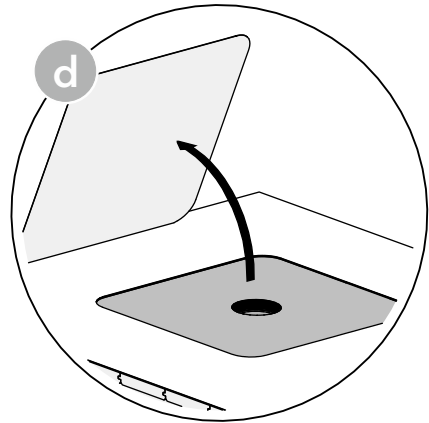
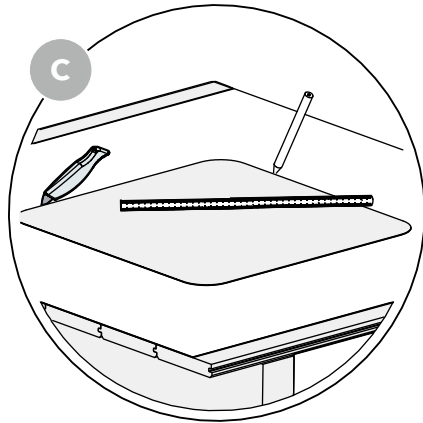
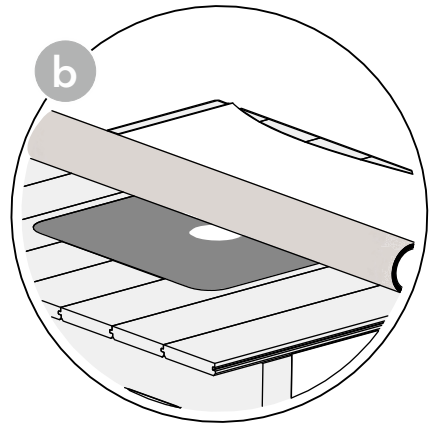
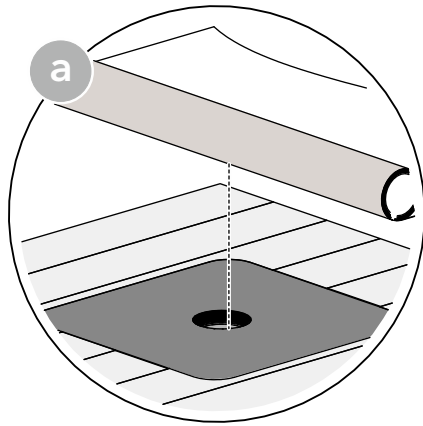
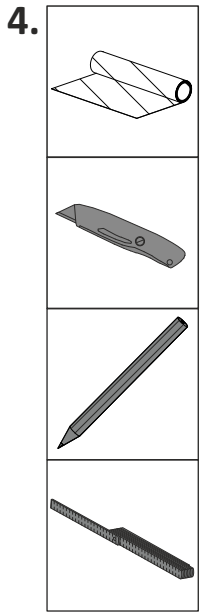

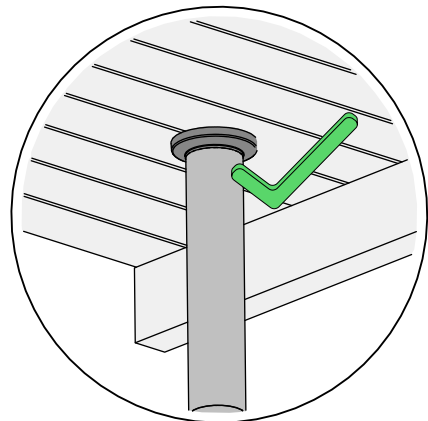
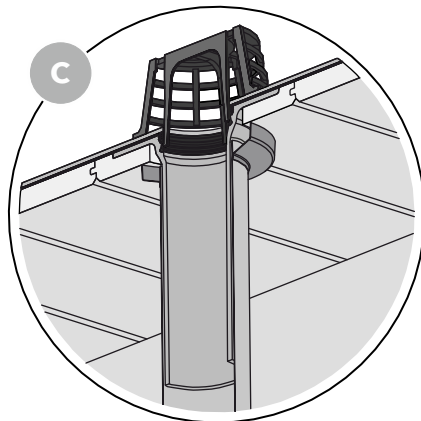
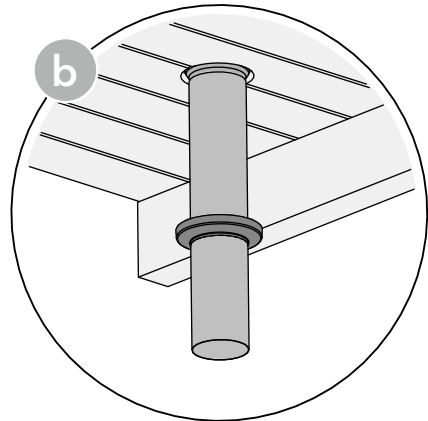
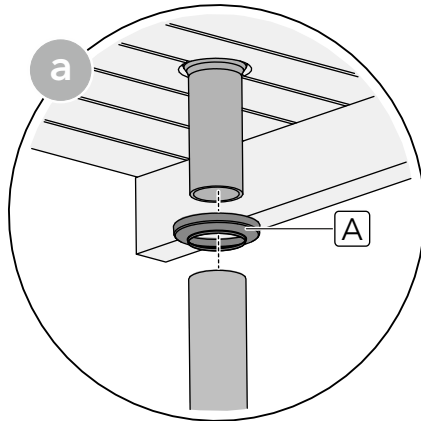
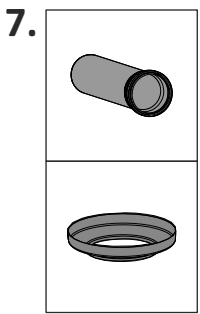
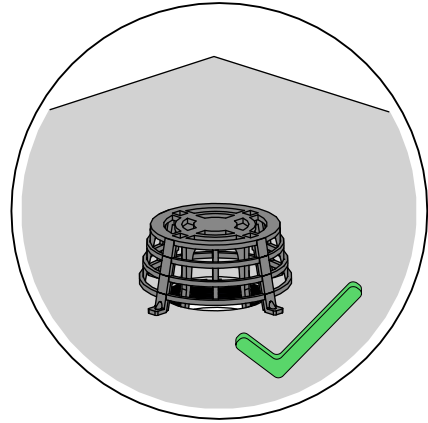
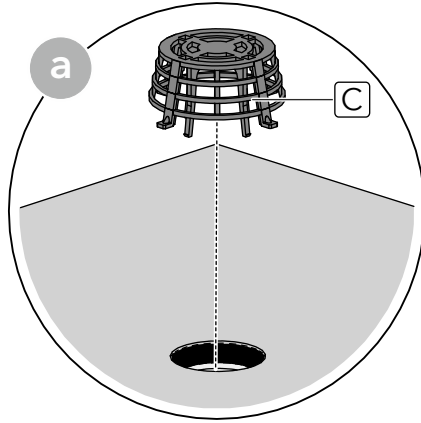
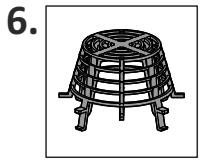



Sita Bauelemente GmbH
Ferdinand-Braun-Str. 1
33378 Rheda-Wiedenbrück
T +49 2522 8340-0
E info@sita-bauelemente.de
W sita-bauelemente.de

